



WOS-2

Wideband Optical Switch

User manual

Rev. J

A large, solid green circular graphic with a white circular cutout in the center, located in the bottom right corner of the page.

Nevion
Nordre Kullerød 1
3241 Sandefjord
Norway
Tel: +47 33 48 99 99
nevion.com

Nevion Support

Nevion Europe

P.O. Box 1020
3204 Sandefjord, Norway
Support phone 1: +47 33 48 99 97
Support phone 2: +47 90 60 99 99

Nevion USA

1600 Emerson Avenue
Oxnard, CA 93033, USA
Toll free North America: (866) 515-0811
Outside North America: +1 (805) 247-8560

E-mail: support@nevision.com

See <http://www.nevision.com/support/> for service hours for customer support globally.

Revision history

Current revision of this document is the uppermost in the table below.

Rev.	Repl.	Date	Sign	Change description
J	H	2016-02-25	OEH	Making all 2x2 drawings consistent with figure 2
H	7	2014-11-27	SHH	Changed optical window specification according to datasheet for optical switch.
7	6	2012-06-11	AJM, JRW	New template , Explained port numbering, 5.1.4-5.1.5
6	5	2007-10-05	AS	New front page and removed old logo.
5	4	2007-10-05	AS	Added Materials Declaration and EFUP
4	3	2003-11-13	RS	Corrected GPI desc. for latching trigger types, added information on adjustable delay for the latching tr. types
3	2	2003-08-15	RS	Added specification on multi mode switch
2	1	2002-12-02	RS	Added information of latching trigger types WOS-2x1L and WOS-2x2L, configuration examples for APS, information on GYDA web interface and RS-422 commands
1	0	2002-05-16	RS	New description of GPI functionality (chapter 4.1)
0	A	2001-10-24	RS	Product release
A	-	2001-09-13	RS	Initial version

Contents

3.1.1 Automatic Protection Switching with WOS-2x1L.....	6
3.1.2 Automatic Protection Switching with WOS-2x2L with monitoring of standby fiber	6
3.1.3 DWDM + Automatic Protection Switching with WOS-2x1L.....	6
3.1.4 DWDM + APS with WOS-2x2L and monitoring of standby fiber	7
4.1.1 Field Modification Instruction, replacement of back plane and PCB.....	8
4.1.2 Applying signals to the connector module	9
5.1.1 GPI – Module Status Outputs and switch alarm inputs, non-latching trigger type	10
5.1.2 GPI – Module Status Outputs and switch alarm trigger inputs, latching trigger type ..	10
5.1.3 Front Panel – Status Monitoring	11
5.1.4 Signal path WOS 2x2-(L)	12
5.1.5 Signal path WOS 2x1-(L)	12

1 Product overview

The Flashlink 2x1 Wideband Optical Switch and 2x2 Wideband Optical Switch are fiber optical SPDT (Single Pole Double Throw) changeover modules for use together with the WOS-C1 connector module.

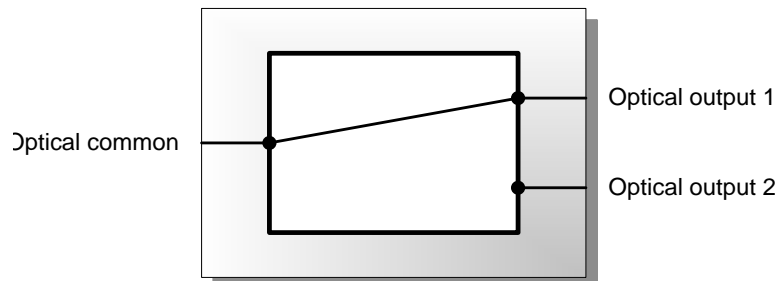

Figure 1: Block diagram of the WOS-2x1 and WOS-2x1L

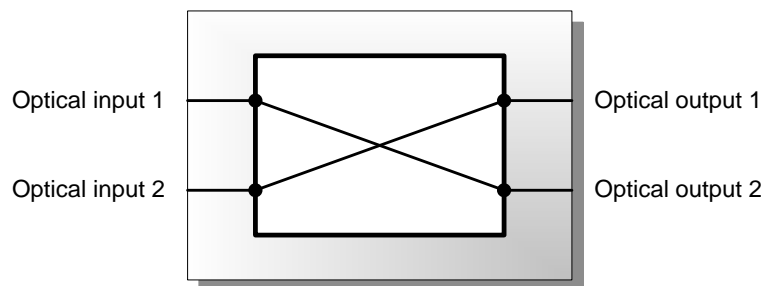

Figure 2: Block diagram of the WOS-2x2 and WOS-2x2L

Typical applications for these units are selective routing of optical signal paths without optical-to-electrical conversion and Automatic Protection Switching (APS). The units are controlled via Flashlink GYDA control system or the GPI interface.

The optical switches operate in the 2nd and 3rd optical windows (1310nm and 1550nm)

The WOS-2x1 has two input/output ports and one common port.

The WOS-2x2 has two input ports and two output ports.

The product is available in four different versions all delivered with WOS-C1 connector module:

WOS-2x1	2x1 Wideband Optical Switch, non-latching trigger type	For selective routing
WOS-2x2	2x2 Wideband Optical Switch, non-latching trigger type	For selective routing
WOS-2x1L	2x1 Wideband Optical Switch, latching trigger type	For APS
WOS-2x2L	2x2 Wideband Optical Switch, latching trigger type	For APS

2 Specifications

2.1 9/125um Single mode fiber

Optical wavelength:	2 nd & 3 rd opt. windows (1290-1610nm)
Insertion loss:	1.4dB typ, max 2.1dB incl. connectors
Connector return loss:	>40dB w/SM fiber
Cross-talk:	<-80dB
Repeatability:	+/- 0.01dB
Durability:	10 000 000 cycles
Switching time:	<50ms typ.
Switching time, latching versions:	<200ms typ.
Connector:	SC/UPC

2.2 62.5/125um Multi mode fiber

Optical wavelength:	2 nd opt. window (1310nm)
Insertion loss:	1.4dB typ, max 2.1dB incl. connectors
Connector return loss:	>20dB w/SM fiber
Cross-talk:	<-80dB
Repeatability:	+/- 0.01dB
Durability:	10 000 000 cycles
Switching time:	<50ms typ.
Switching time, latching versions:	<200ms typ.
Connector:	SC/UPC

2.3 Electrical

Power:	+5V DC / 1W
Control:	Control system for access to setup and module status with BITE (Built-In Test Equipment).

3 Configuration

3.1 Configuration and application examples

3.1.1 Automatic Protection Switching with WOS-2x1L

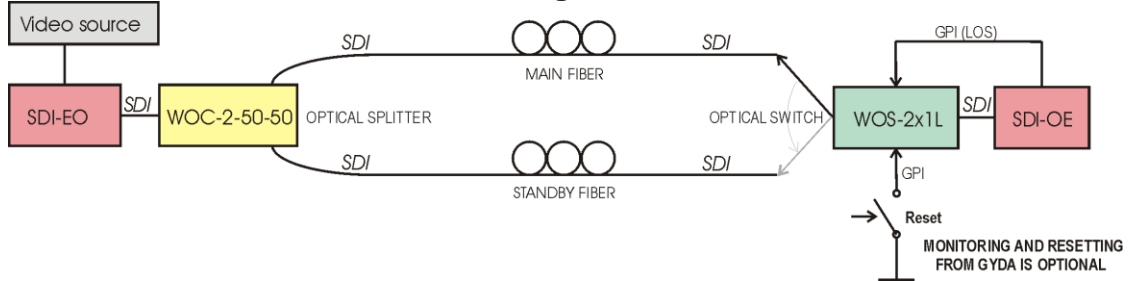

Figure 3: Possible setup for ASP functionality, standby fiber is not monitored.

3.1.2 Automatic Protection Switching with WOS-2x2L with monitoring of standby fiber

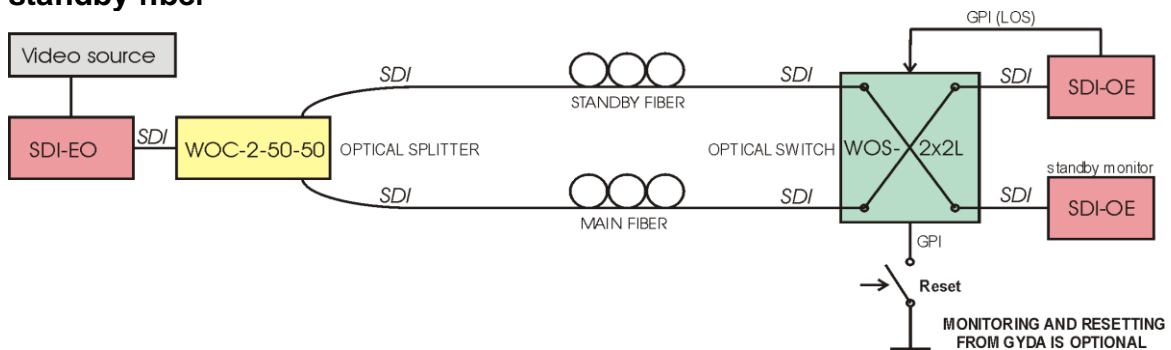

Figure 4: APS, with monitoring of standby fiber, main position.

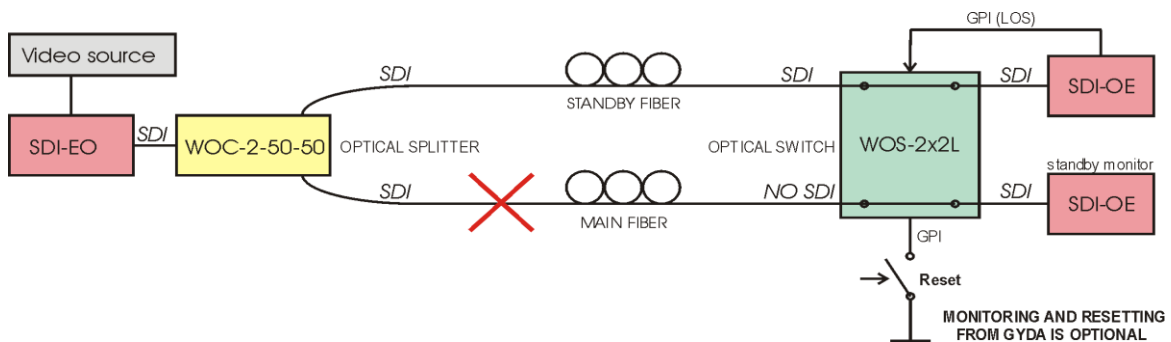

Figure 5: APS, with monitoring of standby fiber, standby position

3.1.3 DWDM + Automatic Protection Switching with WOS-2x1L

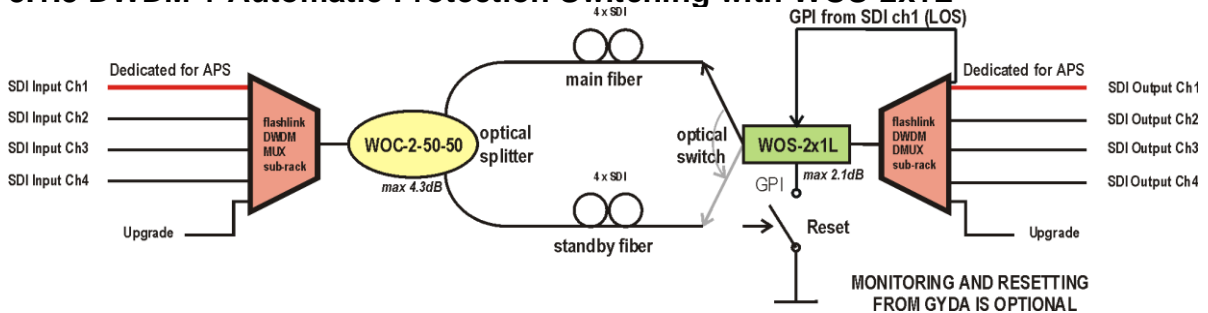

Figure 6: DWDM with APS, without monitoring of standby fiber, main position.

3.1.4 DWDM + APS with WOS-2x2L and monitoring of standby fiber

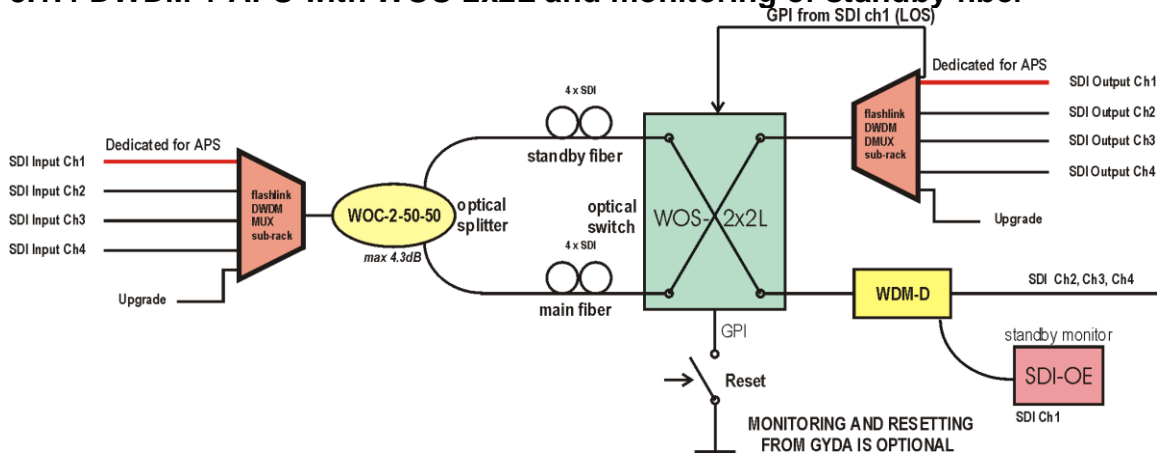

Figure 7: DWDM with APS, with monitoring of standby fiber, main position.

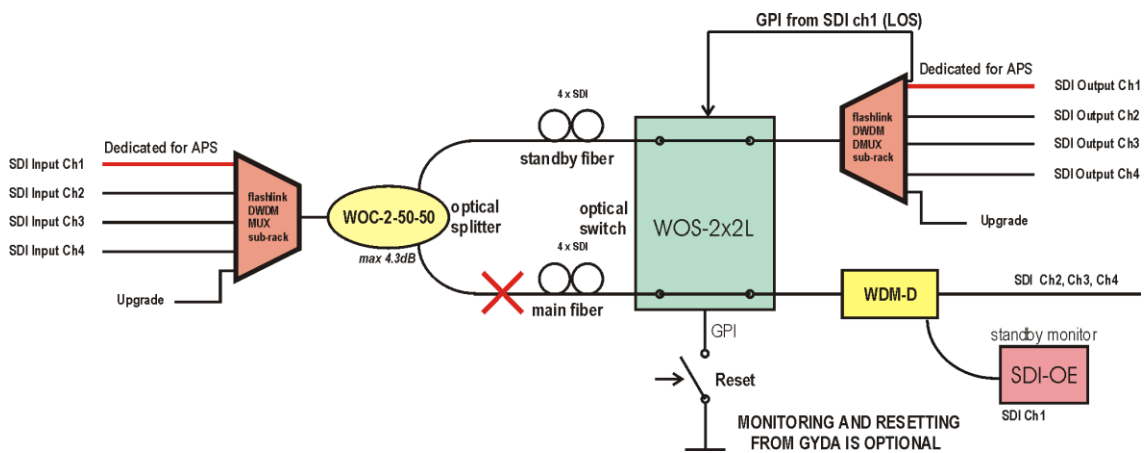
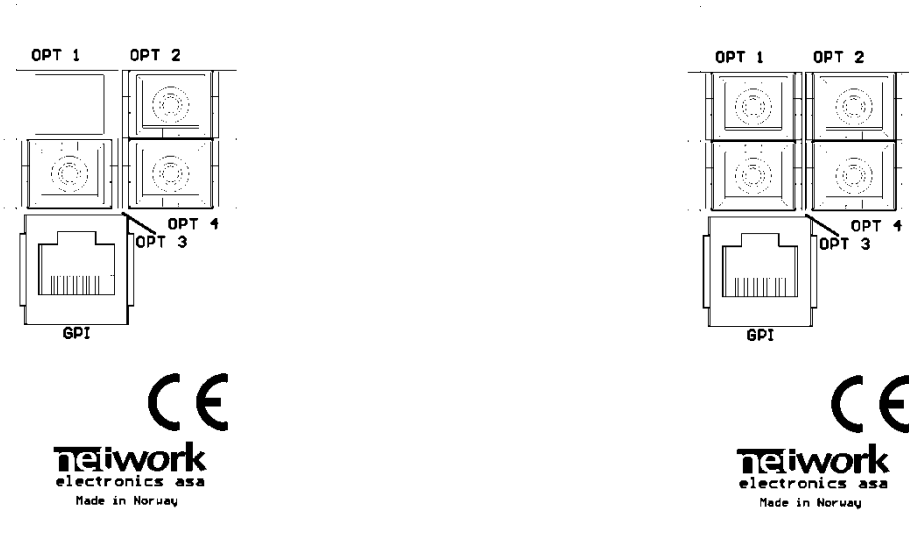

Figure 8: DWDM with APS, with monitoring of standby fiber, standby position.

4 Connections

4.1 Connector module



Overview of the WOS-C1 connector module for 2x1 switch configuration

Overview of the WOS-2x2 connector module for 2x2 switch configuration

4.1.1 Field Modification Instruction, replacement of back plane and PCB.

This Field Modification Instruction from Neviion shows how to replace the back plane on the Flashlink frame. For questions please contact support@neviion.com

1. If there is installed a board in the actual slot from earlier, carefully remove this board first.
2. Carefully remove all 4 screws (2 screws if a blank back plane is mounted) from the back plane to be replaced.
3. Insert the new back plane carefully. Use your business card (or another suitable card), as shown in figure below, to avoid that the EMC shield is damaged when inserting the new back plane.

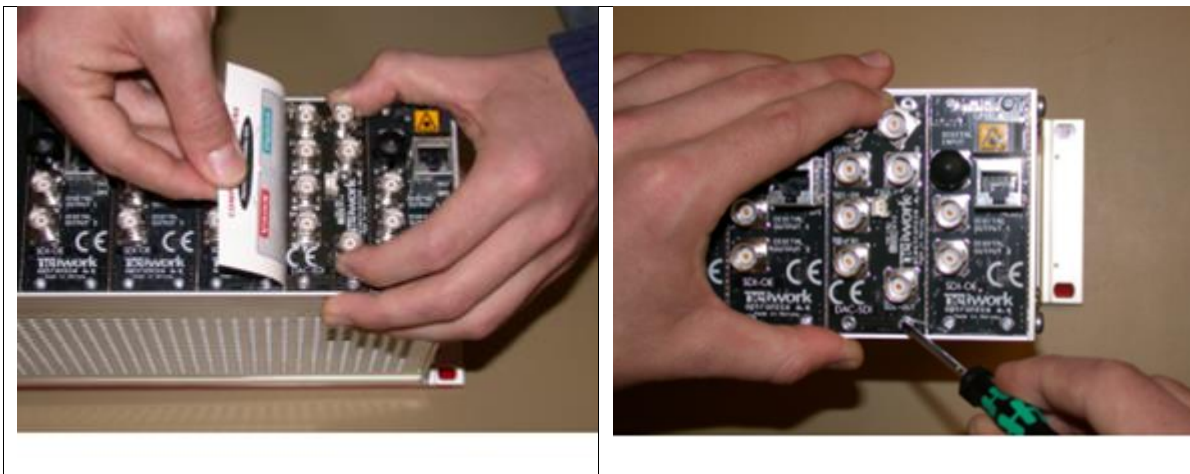

4. Before tightening the screws, use one of your fingers to force the back plane to the bottom of the frame as shown above. Tighten the 2 screws at the bottom at the back plane first. This is to avoid mismatch between the connector on the back plane and the PCB.

5. When inserting the new module for the first time, make sure that the connector on the PCB aligns with connector on the back plane.

NOTE: The PCB shall enter the back plane connector easily

6. If a module is placed in the position left to the module (as seen from the rear), a rubber plug must replace the spring-loaded plastic shield of the fiber adapter.

4.1.2 Applying signals to the connector module

The optical connection is an SC/UPC connector with a return loss better than 40dB typ.

According to SMPTE specifications, the return loss shall be better than 26 dB.

<i>WOS-2x1 and WOS-2x1L:</i>	
Conn. mod. port	Switch port
OPT 1	Not used
OPT 2	Output 1(*)
OPT 3	Common
OPT 4	Output 2(*)

<i>WOS-2x2 and WOS-2x2L:</i>	
Conn. mod. port	Switch port
OPT 1	Input 1
OPT 2	Output 1
OPT 3	Input 2
OPT 4	Output 2

(*) Can also be used as input port, meaning that both 2x1 and 1x2 functionality can be implemented.

5 Operation

5.1 Module status

The status of the module can be monitored in four ways.

1. GPI at the rear of the sub-rack.
2. LEDs at the front of the sub-rack.
3. GYDA-SC controller.
4. Directly accessing the RS-422 bus.

Of these four, the GPI and the LEDs are mounted on the module itself, whereas the GYDA-SC controller is a separate module giving access to remote monitoring of the status of the card through either a web interface or SNMP. The functions of the GPI and the LEDs are described in sections 4.1 to 4.3.

The GYDA-SC controller is described in section 4.4. The commands the modules will respond to over the RS-422 bus, can be found in section 4.5.

5.1.1 GPI – Module Status Outputs and switch alarm inputs, non-latching trigger type

These outputs can be used for wiring up alarms for third party control systems. The GPI output is an open collector output, sinking to ground when an alarm is triggered. The GPI outlet is shown in figure 5. The connector used is RJ-45.

Max output current: 100mA

Max output voltage: 30V

WOS-2x1/WOS-2x2 GPI pinning:

Signal	Name	Pin #	Input/Output	Mode
Status	General error status for the module	Pin 1	Output	Open Collector
Standby	Alarm when switch in standby mode	Pin 2	Output	Open Collector
	Switch to standby mode	Pin 5	Input	0V= standby 5V= main
	Switch to standby mode	Pin 6	Input	
	Switch to standby mode	Pin 7	Input	
Ground	0 volt pin	Pin 8		0V

The switch is set in standby mode by sinking pin5, pin6 or pin7 to ground. Pin6 and pin7 are hardwired as logical OR.

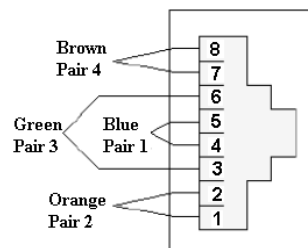

Figure 9: GPI Outlet

5.1.2 GPI – Module Status Outputs and switch alarm trigger inputs, latching trigger type

These outputs can be used for wiring up alarms for third party control systems. The GPI output is an open collector output, sinking to ground when an alarm is triggered. The GPI outlet is shown in figure 6. The connector used is RJ-45.

Max output current: 100mA

Max output voltage: 30V

WOS-2x1/WOS-2x2 GPI pinning:

Signal	Name	Pin #	Input/Output	Mode
Status	General error status for the module	Pin 1	Output	Open Collector
Standby	Alarm when switch in standby mode	Pin 2	Output	Open Collector
	Switch to standby mode	Pin 5	Input	0V= standby 5V= main
	Reset switch to main position	Pin 6	Input	
	Reset switch to main position	Pin 7	Input	
Ground	0 volt pin	Pin 8		0V

The switch is set in standby mode by sinking pin5 to ground. Pin6 and pin7 are hardwired as logical OR and when either is sunk to ground, they will reset the latching switch to main position. Resetting can also be done with GYDA system controller

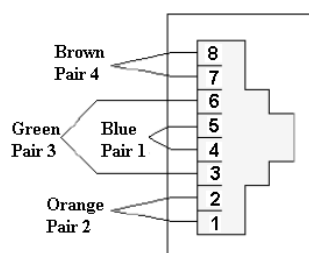

Figure 10: GPI Outlet

5.1.3 Front Panel – Status Monitoring

The status of the module can be easily monitored visually by the LEDs at the front of the module. The LEDs are visible through the front panel as shown in Figure 9

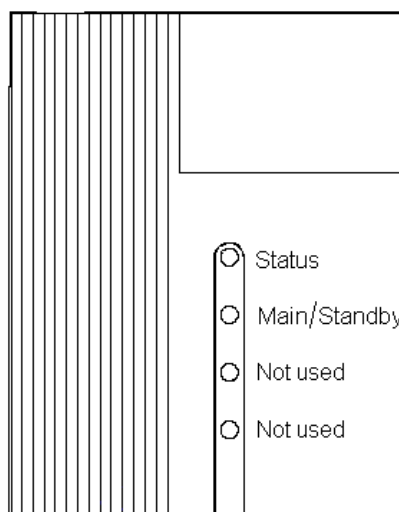

Figure 11: Diode overview of WOS-2x1(L)/WOS-2x2(L)

Both WOS-2x1(L) and WOS-2x2(L) have 2 LEDs each showing a status corresponding to the GPI outputs.

Diode \ state	Red LED	Green LED	No light
Status	Module is faulty	Module is OK Module power is OK	Module has no power
Main/standby	Switch in standby position	Switch in main position	

5.1.4 Signal path WOS 2x2-(L)

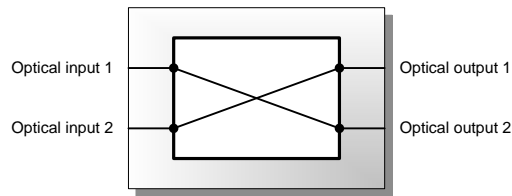

Figure 12: Card configured to main

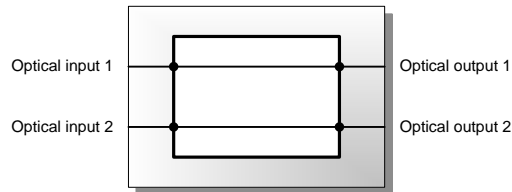

Figure 13: Card configured to backup

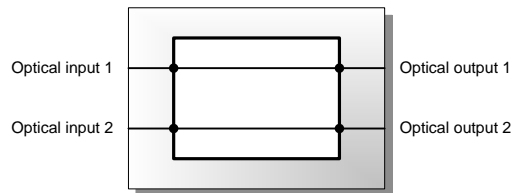

Figure 14: Card without power

5.1.5 Signal path WOS 2x1-(L)

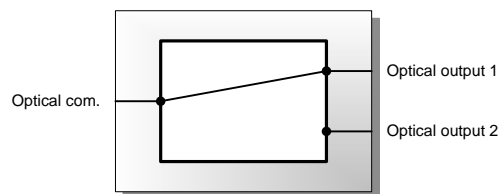

Figure 15: Card configured to main

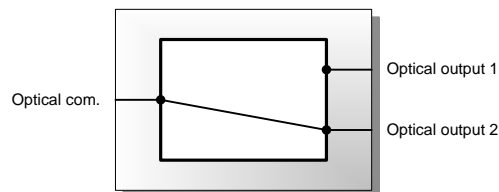

Figure 16: Card configured to backup

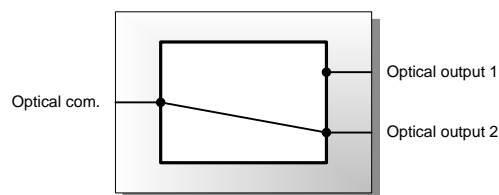

Figure 17: Card without power

5.2 Multicon GYDA System Controller

This card can be controlled and monitored from Multicon Gyda. The status of the switch and the power supply can be monitored, while the switch can be changed from the config pan.

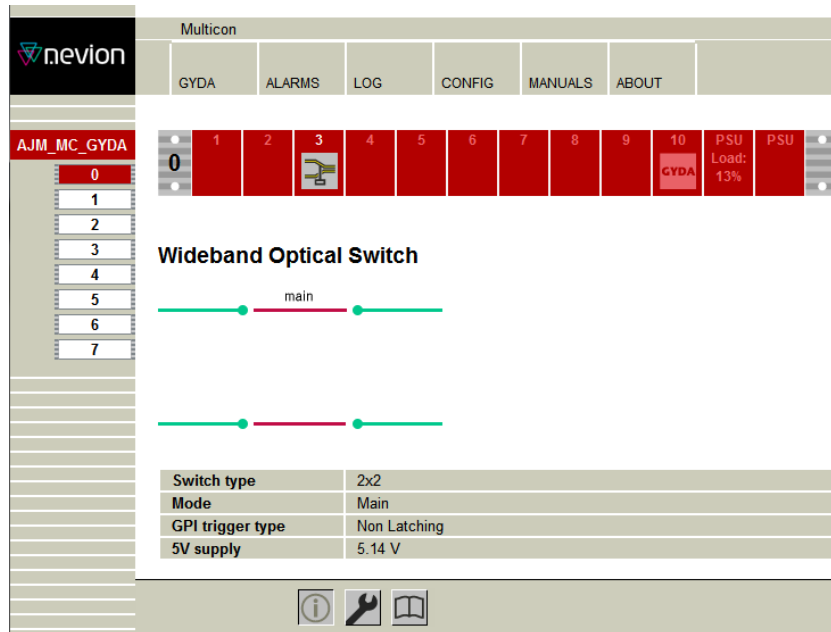

Figure 18: Main page

This card can be controlled and monitored from Multicon Gyda. The status of the switch and the power supply can be monitored, while the switch can be changed from the config pan.

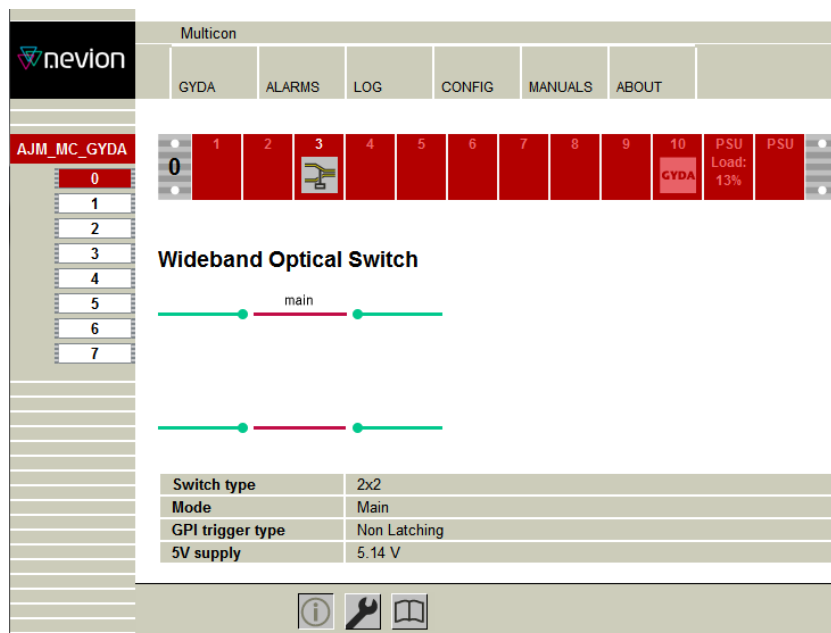

Figure 19: Config page

5.3 RS-422 command set

All commands follow the flashlink protocol, and can be used for direct access to the modules without use of the GYDA-SC, or for third-party control system integration. The flashlink

protocol can be found on our web page <http://nevion.com>

Command	Response	Comment
?	<i>See protocol description</i>	The "hello" command
main	OK	Switch to main position
standby	OK	Switch to standby position
stat	Vcc=... One of the following: mode: main mode: standby mode: standby (gpi) Relay failure	Module status +5V voltage monitoring Main position Standby position Standby pos. GPI active Relay failure

6 Laser safety precautions

Guidelines to limit hazards from laser exposure.

All the available EO units in the flashlink® range include a laser.

Therefore this note on laser safety should be read thoroughly.

The lasers emit light at wavelengths around 1310 nm or 1550 nm. This means that the human eye cannot see the beam, and the blink reflex cannot protect the eye. (The human eye can see light between 400 nm to 700 nm).

A laser beam can be harmful to the human eye (depending on laser power and exposure time). Therefore:

BE CAREFUL WHEN CONNECTING / DISCONNECTING FIBER PIGTAILS (ENDS).

NEVER LOOK DIRECTLY INTO THE PIGTAIL OF THE LASER/FIBER.

NEVER USE MICROSCOPES, MAGNIFYING GLASSES OR EYE LOUPES TO LOOK INTO A FIBER END.

USE LASER SAFETY GOGGLES BLOCKING LIGHT AT 1310 nm AND AT 1550 nm

Instruments exist to verify light output power: Power meters, IR-cards etc.

Flashlink® features:

- All the laser module cards in the Flashlink product range are Class 1 laser products according to IEC 825-1 1993, and class I according to 21 CFR 1040.10 when used in normal operation.
- More details can be found in the user manual for the FR-2RU-10-2 frame.
- Maximum output power*: 5 mW.
- Operating wavelengths: > 1270 nm.

**Max power is for safety analysis only and does not represent device performance.*

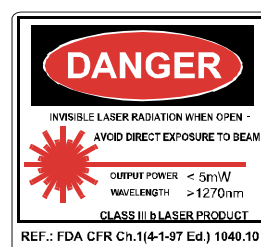

General environmental requirements for Nevion equipment

1. The equipment will meet the guaranteed performance specification under the following environmental conditions:
 - Operating room temperature range: 0°C to +50°C
 - Operating relative humidity range: <90% (non-condensing)

2. The equipment will operate without damage under the following environmental conditions:
 - Temperature range: -10°C to +55°C
 - Relative humidity range: <95% (non-condensing)

Product Warranty

The warranty terms and conditions for the product(s) covered by this manual follow the General Sales Conditions by Nevion, which are available on the company web site:

www.nevion.com

Appendix A Materials declaration and recycling information

A.1 Materials declaration

For product sold into China after 1st March 2007, we comply with the “Administrative Measure on the Control of Pollution by Electronic Information Products”. In the first stage of this legislation, content of six hazardous materials has to be declared. The table below shows the required information.

組成名稱 Part Name	Toxic or hazardous substances and elements					
	鉛 Lead (Pb)	汞 Mercury (Hg)	鎘 Cadmium (Cd)	六价铬 Hexavalent Chromium (Cr(VI))	多溴联苯 Polybrominated biphenyls (PBB)	多溴二苯醚 Polybrominated diphenyl ethers (PBDE)
WOS-2	○	○	○	○	○	○
<p>O: Indicates that this toxic or hazardous substance contained in all of the homogeneous materials for this part is below the limit requirement in SJ/T11363-2006.</p> <p>X: Indicates that this toxic or hazardous substance contained in at least one of the homogeneous materials used for this part is above the limit requirement in SJ/T11363-2006.</p>						

This is indicated by the product marking:



A.2 Recycling information

Nevion provides assistance to customers and recyclers through our web site <http://www.nevion.com/>. Please contact Nevion’s Customer Support for assistance with recycling if this site does not show the information you require.

Where it is not possible to return the product to Nevion or its agents for recycling, the following general information may be of assistance:

- Before attempting disassembly, ensure the product is completely disconnected from power and signal connections.
- All major parts are marked or labeled to show their material content.
- Depending on the date of manufacture, this product may contain lead in solder.
- Some circuit boards may contain battery-backed memory devices.