



Control Panels VikinX Sublime series

User manual

Rev. M

A large, solid green circular graphic with a white circular cutout in the center, positioned in the bottom right corner of the page.

Nevion
Nordre Kullerød 1
3241 Sandefjord
Norway
Tel: +47 33 48 99 99
neviON.com

Nevion Support

Nevion Europe

P.O. Box 1020
3204 Sandefjord, Norway
Support phone 1: +47 33 48 99 97
Support phone 2: +47 90 60 99 99

Nevion USA

1600 Emerson Avenue
Oxnard, CA 93033, USA
Toll free North America: (866) 515-0811
Outside North America: +1 (805) 247-8560

E-mail: support@nevision.com

See <http://www.nevision.com/support/> for service hours for customer support globally.

Revision history

Current revision of this document is the uppermost in the table below.

Rev.	Repl.	Date	Sign	Change description
M	11	2013-07-18	JGS	Updated chapter 5.2 with supported network modes
11	10	2011-12-12	NBS/AAA	Corrected protocol options in Chapter 3.7. Appendix B removed. Alarm list in Chapter 4.2 updated.
10	9	2011-08-22	NBS	Updated Chapter 7.1.2.
9	8	2011-07-14	NBS	Added Error! Reference source not found.. Added Grass Valley Native Protocol in Chapter 3.7 and Appendix B.2. Added Chapter 7.1.10. Changed Chapter 7.1.1. Updated Declaration of Conformity.
8	7	2011-03-29	NBS	Updated Chapter 3.3 and 3.7. Corrected housing and gender spec on D-sub 9-pin contacts. Added Declaration of Conformity. Removed old Revision history.
7	6	2011-01-04	NBS	Updated information about configuration of GPI fallback input (Chapter 3.2.1). Updated protocol options in Chapter 3.7. Added comment on redundant controller support in Chapter 5.2.
6	5	2010-08-13	NBS	Updated Chapter 3.6. Added salvo limitations in Chapter 7.1.

Contents

Revision history	2
1 Product overview	5
1.1 Product versions	5
2 Specifications	6
2.1 Mechanics.....	6
2.1.1 Weight and power consumption	6
2.2 Power Supply	6
2.3 Control	6
2.4 Connection details.....	7
2.4.1 Power Supply pin-out	7
3 Configuration	8
3.1 Level configuration	8
3.2 Fallback mode.....	8
3.2.1 Configuration of fallback input	9
3.3 Joystick priority.....	9
3.4 Power alarm.....	9
3.5 Joystick mode	9
3.6 Configuring active output on Single bus panels	10
3.7 Configuring protocol options.....	10
4 LED status indication	12
4.1 Start-up	12
4.2 Alarm states	12
4.3 Ethernet states	12
5 Router communication.....	13
5.1 Serial connection.....	13
5.1.1 Maximum cable length (RS-232)	13
5.2 Ethernet connection	14
5.2.1 HW limitations	14
5.3 NCB connection	15
5.3.1 Connecting control panels	15
5.3.2 Pin-out and cable type.....	15
5.3.3 Termination plug	17
5.3.4 Control bus structure	17
5.3.5 Maximum distance between NCB devices.....	17
6 GPI connections	18
7 Control Panel operation.....	19
7.1 Button description	19
7.1.1 A/V Toggle	19
7.1.2 Panel Enable.....	20
7.1.3 Take on/off	20
7.1.4 Take.....	20
7.1.5 Output	20
7.1.6 Input.....	20
7.1.7 XY	20
7.1.8 Salvo.....	21
7.1.9 Lock	21

7.1.10 Protect.....	21
General environmental requirements for Nevia equipment	22
Product Warranty.....	23
Important notes regarding Software in the VikinX Sublime router family range	24
Appendix A Materials declaration and recycling information	25
A.1 Materials declaration.....	25
A.2 Recycling information.....	25

1 Product overview

Nevion are proud to present the 2nd generation of the compact small and medium routing switcher family, Sublime. With Sublime, Nevision now provide a stable and proven product line including the most complete signal format and size offering available.

With the new ultra slim, multi format and flexible product range, Sublime fulfills the most demanding requirements from the professional broadcast market.

VikinX Sublime provides many of the powerful control features that drove the VikinX Modular range to success. VikinX Sublime is ideal for general purpose facilities, on-air routing, mobile outside broadcast applications and sophisticated A/V applications.

This user manual presents the features, installation and operation procedures of the control panels of the Sublime range.

1.1 Product versions

The following versions of the VikinX Sublime Control Panels are available:

Control Panels – 19” – 1RU:

SL-8XY-CP	Multi bus X-Y 8x8 panel.
SL-8S-CP	Single bus 8x1 panel.
SL-8S-CP-GPI	Single bus 8x1 panel with GPI / Joystick / Tally interface.
SL-16XY-CP	Multi bus X-Y 16x16 panel.
SL-16D-CP	Dual bus 16x2 panel.
SL-16S-CP	Single bus 16x1 panel.
SL-16S-CP-GPI	Single bus 16x1 panel with GPI / Joystick / Tally interface.
SL-32S-CP	Single bus 32x1 panel.
SL-32S-CP-GPI	Single bus 32x1 panel with GPI / Joystick / Tally interface.

Control Panels – 19” – 2RU¹:

SL-32XY-CP	Multi bus X-Y 32x32 panel.
SL-64S-CP	Single bus 64x1 panel.
SL-64S-CP-GPI	Single bus 64x1 panel with GPI / Joystick / Tally interface.

Control Panels – 19” – 4RU²:

SL-64XY-CP	Multi bus X-Y 64x64 panel.
------------	----------------------------

¹ Sublime 2RU Control Panels come with 2 additional, programmable buttons on the bottom left side. These buttons may be programmed in the same way as any of the other programmable buttons.

² Sublime 4RU Control Panels come with 6 additional, programmable buttons on the bottom left side. These buttons may be programmed in the same way as any of the other programmable buttons.

2 Specifications

2.1 Mechanics

Dimensions:	-	HxWxD = 44x483x50mm, (19", 1RU);
	-	HxWxD = 88x483x50mm, (19", 2RU);
	-	HxWxD = 176x483x50mm, (19", 4RU).
Safety/Emission standards:		Compliant with CE EN55103-1 and 2.

2.1.1 Weight and power consumption

Device	Weight, incl. 1x PSU	Current +15V	Current -15V	Power
SL-8XY-CP	1.0 kg	300 mA	3 mA	5 W
SL-8S-CP	1.0 kg	300 mA	3 mA	5 W
SL-8S-CP-GPI	1.2 kg	400 mA	3 mA	6 W
SL-16XY-CP	1.0 kg	300 mA	3 mA	5 W
SL-16D-CP	1.0 kg	300 mA	3 mA	5 W
SL-16S-CP	1.0 kg	250 mA	3 mA	4 W
SL-16S-CP-GPI	1.2 kg	400 mA	3 mA	6 W
SL-32XY-CP	1.4 kg	300 mA	3 mA	5 W
SL-32S-CP	1.0 kg	300 mA	3 mA	5 W
SL-32S-CP-GPI	1.3 kg	400 mA	3 mA	6 W
SL-64XY-CP	2.1 kg	300 mA	3 mA	5 W
SL-64S-CP	1.4 kg	300 mA	3 mA	5 W
SL-64S-CP-GPI	1.6 kg	400 mA	3 mA	6 W
SL-PWR-40 (PSU)	0.35 kg		N/A (AC Mains)	

2.2 Power Supply

SL-PWR-40	40W Power Supply Unit.
AC Supply voltage range:	100-240VAC, 50-60Hz, Max 1.6A.
AC Mains connector:	IEC 320.
DC output:	+15V, max. 2.2A / -15V, max 1.35A. Maximum 43W.
DC connector:	DE9, D-sub 9-pin male.
Status monitoring:	Via LED in front of the router/CP.
Safety standards:	Compliant with CE EN60950, UL-1950/CSA22.2.

2.3 Control

Standard Features:

Serial port:	RS-232 for protocol conversion, to VikinX compact control protocol, or to third party protocols.
Connector:	DE9, D-sub 9-pin female.
NCB ports:	For integration with VikinX compact router configuration.
Connectors (2):	RJ45 (1 In / 1 Out)
Ethernet port:	10/100BaseT Ethernet bus for external router control.
Connector:	RJ45.

2.4 Connection details

The Sublime routers and control panels have the following service connections on the rear of each product:

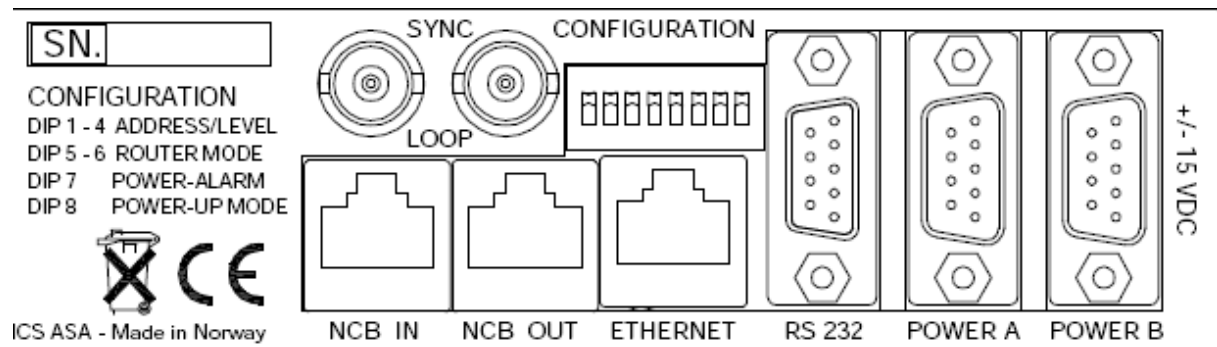

Figure 1: Sublime service connectors.

- SYNC:** *Not in use on Control Panels.*
- LOOP:** *Not in use on Control Panels.*
- NCB IN:** Network Control Bus Input. The protocol of this bus is described in a separate manual.
- NCB OUT:** Network Control Bus Output.
- ETHERNET:** 10/100Base-T Ethernet bus for external router control.
- RS 232:** RS-232 for external control protocols.
- POWER A:** ±15VDC power connector.
- POWER B:** ±15VDC power connector, redundant supply.
- CONFIGURATION:** Configurations switch. See Chapter 3 for further descriptions.

2.4.1 Power Supply pin-out

The DE9 male sockets for the power connection on Sublime routers and Control Panels have the following pin-out;

Pin #	Description
1	GND
2	Not connected
3	Not connected
4	+15VDC
5	Not connected
6	Not connected
7	Not connected
8	-15VDC
9	Not connected

3 Configuration

This chapter provides an overview of the configuration options that are available on the Sublime Control Panels.

3.1 Level configuration

Switches 1 - 4 on the configuration switch set the CP's level for communication with the Router Management System and other units in the NCB system. Panels on the NCB dedicated to operate with the router must be configured to the same level as that router.

The levels can be switched according to the following pattern:

SW 1	SW 2	SW 3	SW 4	Level	NCB Address
OFF	OFF	OFF	OFF	1	0
OFF	OFF	OFF	ON	2	1
OFF	OFF	ON	OFF	3	2
OFF	OFF	ON	ON	4	3
OFF	ON	OFF	OFF	5	4
OFF	ON	OFF	ON	6	5
OFF	ON	ON	OFF	7	6
OFF	ON	ON	ON	8	7
ON	OFF	OFF	OFF	9	8
ON	OFF	OFF	ON	10	9
ON	OFF	ON	OFF	11	10
ON	OFF	ON	ON	12	11
ON	ON	OFF	OFF	13	12
ON	ON	OFF	ON	14	13
ON	ON	ON	OFF	15	14
ON	ON	ON	ON	16	15

Default level is 1.

It is possible to control more than 1 level with Sublime panel. See Chapter 7.1.1 for more information.

3.2 Fallback mode

This information is only applicable on GPI versions, with the Joystick release mode enabled. See Chapter 3.5.

Switch 5 on the configuration switch sets the fallback mode of the GPI panel, either to *dynamic* or to *hard-set*.

- *Dynamic fallback mode.* When the GPI is activated the X-point status is saved before switching. When the GPI is released again, the panel will switch back to the previous saved X-point status.
- *Hard-set fallback mode.* When the GPI is released, the panel will switch to a previously configured fallback input. The fallback input is configured using the input buttons.

The modes can be switched according to the following pattern:

SW 5	Fallback mode
OFF	Hard-set
ON	Dynamic

Default mode is *Hard-set*.

3.2.1 Configuration of fallback input

1. Enable the panel.
2. Press and Hold the *Panel Enable* button and then press the *A/V Toggle* button.
3. While still holding *Panel Enable*, select the fallback input by pressing the associated *Input* button.
4. Release the *Panel Enable* button. The panel will now be disabled.
5. Press the *Panel Enable* button again to enable it.

3.3 Joystick priority

This information is only applicable on GPI versions.

Switch 6 on the configuration switch set the Joystick priority of the GPI panel, either to *release before switch* or to *switch before release*.

The release modes relates to how the user operates the joystick on a Camera Control Unit. When the operator pushes down on the joystick there will be a contact closure on the GPI out of the CCU, and when the user releases the joystick the contact opens.

Normally, multiple CCUs will be connected to individual GPI inputs on the Sublime CP.

- *Release before switch*. Used in both GPI and Joystick mode. The activation of a new input line will have no effect until the previous line is released. If more lines are activated in sequence, the latest activated one will result in a switching as soon as the previously active is released. I.e. only one GPI will be active at a time – i.e. the first CCU with a contact closure “wins”. No other GPI can be triggered before the first CCU releases the contact closure.
- *Switch before release*. Used in both GPI and Joystick mode. The activation of a new input line will generate a switching, regardless of how many other lines that are already set. I.e. multiple GPIs can be active at the same time.

The priority can be switched according to the following pattern:

SW 6	Joystick priority
OFF	Switch before release
ON	Release before switch

Default mode is *Switch before release*.

3.4 Power alarm

The power alarm can be switched according to the following pattern:

SW 7	Power alarm
OFF	Disables Power Alarm
ON	Enables Power Alarm

Default setting is *Power alarm disabled*.

3.5 Joystick mode

This information is only applicable on GPI versions.

Switch 8 on the configuration switch set the Joystick mode of the GPI panel, either to *GPI mode* or to *Joystick release mode*.

- *GPI mode*. Releasing the input lines will keep the previous status. Operation of the front panel is allowed with any number of active GPI-lines simultaneously.

- *Joystick release mode*. When all the input lines are released, a default input (either dynamically chosen or static) is set. The front panel is locked if any of the input lines are active.

The modes can be switched according to the following pattern:

SW 8	Joystick mode
OFF	GPI mode
ON	Joystick release mode

Default mode is *GPI mode*.

3.6 Configuring active output on Single bus panels

Use the **Input button** to select the active output on single bus panels. It requires that a Panel Enable button is present.

When the panel is enabled, press the Panel Enable button and hold it while selecting the active output by pressing an Input button. Then release the Panel Enable button. The panel will now be disabled. Press the Panel Enable button again to enable it.

Example: If you want your Single Bus panel to control *Output 7* of your router; follow the procedure described above, pressing *Input 7*.

3.7 Configuring protocol options

For various reasons, Nevon has decided to make it possible to turn the extra commands that were added to the NCB protocol when we introduced the Sublime router range either off or on.

At the same time, the user must select whether he/she shall use the RS-232 port for controlling the router **or** the Ethernet port. This is done in order to prevent both ports from simultaneously being applied for controlling the router.

There is a new Protocol field in the System Configurator where you may choose from the following options;

- **NCB without Sublime ext. (RS232)**
This is the “old” Compact NCB protocol, without Sublime extensions. If used on a Sublime, it also disables the Ethernet port of that device.
- **NCB (RS232)**
This is the regular Sublime protocol, with the extra commands that were added to the NCB protocol. If used on a Sublime, it also disables the Ethernet port of that device. This is the default option for the *Sublime* (SL) range of products.
- **MRP (TCP/IP)**
This option is only applicable to the Sublime range. It selects the Ethernet protocol as the control option, and disables the RS-232 port of that device.

This option allows the user to control Sublime routers that have other, 3rd party TCP/IP protocols enabled. MRP is always enabled on Sublime routers when they are configured for 3rd party TCP/IP control protocols.

Note that the above selection is only possible if you have Sublime FW rel. 2.1.1 or newer installed on your Sublime device, and System Configurator rel. 3.3.5 or newer installed on your PC.

It is NOT possible to select protocol options on Sublimes with HW rev. 1.

Use your System Configurator to verify the HW revision of your Sublime unit:

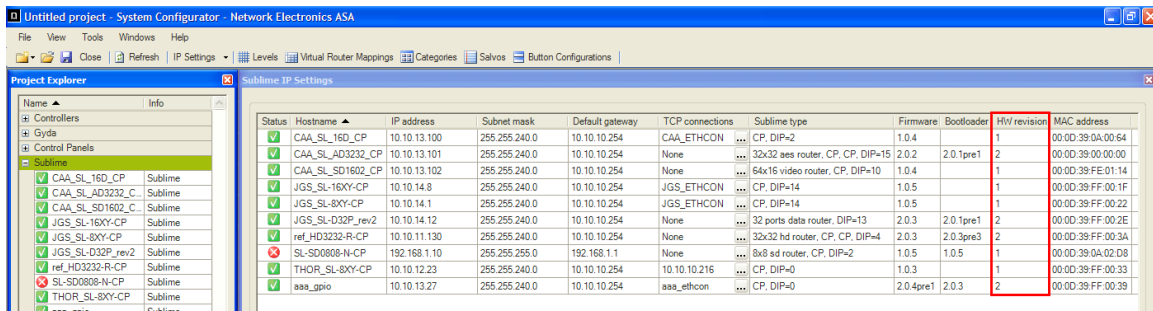

Figure 2: HW verification in Neveon Configurator.

Right-click the column headers and select the appropriate column to be shown, if you don't see the appropriate column in your default display.

For further information about FW releases, please go to the Neveon web site to download, or check available FW releases: www.neveon.com.

4 LED status indication

4.1 Start-up

The LED located at the front of the control panel indicates the status of the panel. At start-up, the LED will alternate between red (R) and green (G) every 500ms for about two seconds. After the start-up sequence the LED will indicate the Alarm state of the panel.

There are two LEDs located at the Ethernet bus. At start-up the boot loader is searching for update commands on the serial port for about two seconds. During this sequence both Ethernet LEDs will be blinking. After the start-up sequence the LEDs will indicate the Ethernet state.

4.2 Alarm states

The LED can either be red (R), green (G), yellow (Y) or have no light (N).

The LED state is here described with twenty letters, each representing 100ms, which totals to an alarm sequence of two seconds. The X indicates that the LED keeps the color it has the moment the alarm sequence begins (green, yellow or no light).

Description	LED state	Alarm	Comment
Continuous green light	GGGGG GGGGG GGGGG GGGGG	No alarm. Status is OK.	
Continuous yellow light	YYYYY YYYYY YYYYY YYYYY	Unable to connect to controller over Ethernet.	This alarm will be overwritten by other alarms
Long red blinks	RRRRR NNNNN RRRRR NNNNN	Power is too low.	
One short red blink	RXXXX XXXXX XXXXX XXXXX	Power A failed	Only active if power alarm dip is set.
Two short red blinks	XXXXX XXXXX RXRXX XXXXX	Power B failed	Only active if power alarm dip is set.
Red with one short yellow blink	YRRRR RRRRR RRRRR RRRRR	No valid product key.	

4.3 Ethernet states

The LEDs that are located at the Ethernet bus will after the Start-up sequence indicate the Ethernet states:

	On	Off / Blinking
Green	Valid link	No link
Yellow	No data	Data is transmitted or received

5 Router communication

You gain access to router for communication purposes by connecting either the router's serial port to your computer or by using an Ethernet connection.

Do not use both the router's Ethernet port and RS-232 serial port, or NCB ports, at the same time. Doing so may cause loss of important communication and control data.

5.1 Serial connection

Connection can be made through the serial port of the router; see also Chapter 0 for connection details.

The communication parameters are configurable. Please refer to the protocol documentation of the appropriate communication/control protocol.

Example: The protocol parameters of the *VikinX Compact routers* are as follows:

- Bit rate 19200 bit/s
- Data bits 8 bits
- Stop bits 1
- Parity: No parity

For further details concerning this protocol, please refer to the following manual:

[NCB Protocol.pdf](#).

The DE9 female socket for the serial port of the router has the following pin-out:

Pin #	RS-232 mode
1	<i>Not in use</i>
2	Tx
3	Rx
4	<i>Not in use</i>
5	GND
6	GND
7	RTS
8	CTS
9	<i>Do Not Connect!</i>

Note that if the standard RS-232 cable specification (DCE) is followed:

A cable with Male+Male or Female+Female connectors at the cable ends is used for Rx/Tx crossed connection, and

A cable with Male+Female connectors at the cable ends is used for a straight through connection.

5.1.1 Maximum cable length (RS-232)

IEEE has specified the maximum cable length for an RS-232 connection to 15m. Longer distances can be installed depending on the environmental conditions of the installation site.

It is the responsibility of the installer / user to secure a proper installation of the RS-232 connection.

5.2 Ethernet connection

The connections follow the standard set by the IEEE 802.3 100BaseTX specification. The cables that are to be applied should be CAT-5 / CAT-5E standard, or better. It is the responsibility of the installer / user to secure a proper installation of the Ethernet connection.

A VikinX Sublime device supports the following setups:

- 100 Mb/s, half duplex (default)
- 10 Mb/s, half duplex

This setup is valid from VikinX Sublime firmware 2.6.3 and newer. Changing the ethernet setup on a VikinX Sublime must be done with the Nevision Configurator, version 4.4.0 or newer.

All VikinX Sublime routers and IP-based Control Panels are connected together through an Ethernet Switch.

A VikinX Sublime device has only one physical Ethernet connection. If redundant control is required, this limitation has to be solved by the control system.

Sublime Control Panels do not support *redundant controller* setup. Use VikinX IP based control panels for that purpose.

For Ethernet protocol details concerning this router, please refer to the following manual: Modular Router Control Protocol. This manual can be found on our web site: <http://www.nevion.com>.

5.2.1 HW limitations

With the introduction of Sublime controller HW Rev.2, the user has the option of connecting more than two devices together, without having a Multicon to control the network. See Chapter 3.7 for verification of the HW revision of your device.

Unless you apply a Multicon as a system controller, the limitations that apply are:

1. One Sublime control panel may connect to a maximum of 4 Sublime routers.
2. One Sublime router may be controlled by a maximum of 4 Sublime control panels.

Exceptions to the above limitations:

A router with a local CP (e.g. SL-V6464-CP) may only connect to 1 other router. Both routers must be configured with the same address and be of different type (A+V).

Example: 1x SL-V6464-CP may only control itself + 1x Audio router (AA or AES). Both routers must be configured with the same address.

16x2 routers that are expanded to NNx2 are using the NCB bus for this purpose. The total NNx2 router is therefore counted as 1 router in the limitations 1 and 2 above.

From limitations 1 and 2 above, the resulting Ethernet configuration may consist of maximum 8 devices; 4 routers and 4 control panels, with the exceptions mentioned above. An example is illustrated in the figure below.

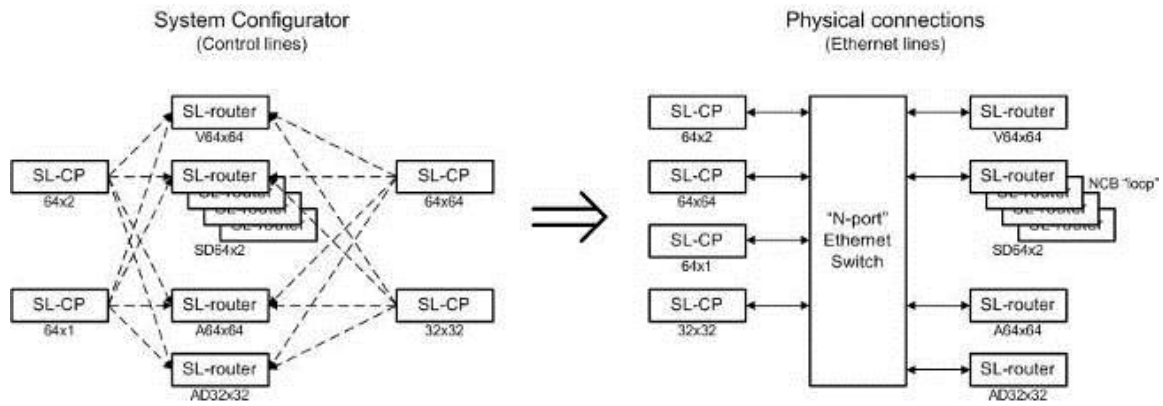

Figure 3: Ethernet connections and configuration.

Refer to the System Configurator User Manual for further information about the above described configuration/connection options.

It is NOT possible to connect more than 2x Sublimes with HW rev. 1 together via Ethernet, unless a Multicon is applied as system controller.

5.3 NCB connection

Via the Network Control Bus system several routers and control panels can be interconnected.

Up to 16 levels of routers, or combinations of routers, can be controlled. The NCB system and all RS 232 ports interchange the system status. This means that any control system, either from Nevia, or from a third party manufacturer, connected to any RS 232 port in the NCB loop, will have access to all communication data on the bus.

5.3.1 Connecting control panels

To get a control panel working with a specific router, configure the control panel to the same level as the router. Several panels can be configured to control the same router. Panels can also be connected to a router via the RS-232 interface. Please refer to your control panel manual for installation.

5.3.2 Pin-out and cable type

VikinX Sublime routers and Control Panels use RJ45 connectors for the Network Control Bus ports. The following pin-out is used:

- Pin #1 Not Connected
- Pin #2 Not Connected
- Pin #3 Data (retour)
- Pin #4 Data
- Pin #5 Data
- Pin #6 Data (retour)
- Pin #7 Not Connected
- Pin #8 Not Connected

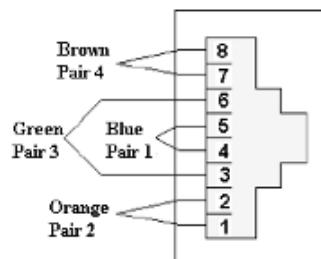

The following connection example shows connection of 4 VikinX devices with RJ45 connectors and bus termination:

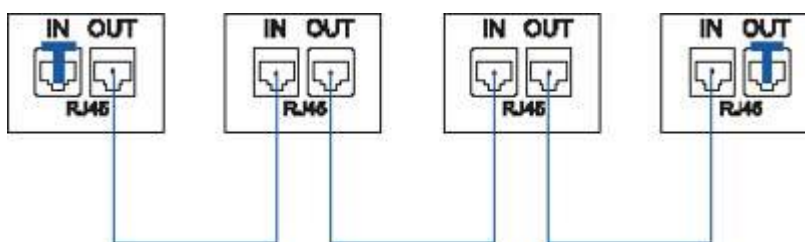

Figure 4: NCB loop configuration.

Note that each device at the end of the chain has a termination plug, indicated with the letter "T". This termination plug must be inserted in the correct connection port. If not, no NCB communication is possible.

5.3.3 Termination plug

The termination plug that is mentioned in the previous chapter is necessary when you want to avoid closing the loop by a (long) cable.

The termination plug is a standard RJ45 plug with the following internal wiring:



Figure 5: NCB loop termination plug.

As seen in the figure above, *Pin 3* is connected to *Pin 4*, and *Pin 5* is connected to *Pin 6*.

5.3.4 Control bus structure

The Network Control Bus structure follows the standard MIDI bus definition. The NCB is defined as a closed chain of units. This means that the NCB OUT of the last unit must be connected to the NCB IN of the first unit in the NCB chain. To avoid problems with the control of VikinX units the installer/user has to assure that the bus structure is installed according to this definition.

The total number of VikinX devices in an NCB chain is limited to 50.

5.3.5 Maximum distance between NCB devices

The standard MIDI definition allows a maximum cable length of 200-250 meters between two devices. Longer distances can be made with MIDI repeater units. To avoid grounding problems all NCB ports have opto-coupled inputs.

6 GPI connections

This information is only applicable on GPI versions.

The GPI / Joystick / Tally signals are connected to the Sublime Control Panel with GPI options using DB25 male connectors. Each Sublime CP with GPI I/O has 32 GPI inputs and 32 GPI outputs available, independent of panel size.

The GPI connectors on the CP are DB25 females.

The following pin-out applies:

GPI I/O Channel #	Connector pin #
1 and 17	12
2 and 18	24
3 and 19	23
4 and 20	10
5 and 21	09
6 and 22	21
7 and 23	20
8 and 24	07
9 and 25	06
10 and 26	18
11 and 27	17
12 and 28	04
13 and 29	03
14 and 30	15
15 and 31	14
16 and 32	01

- *Inputs* are internally connected to +5V via a pull-up resistor. The inputs will be activated when pulling them to ground. Ground is available on the following pins: 2, 5, 8, 11, 13, 16, 19, 22, 25 and on the connector chassis.
- *Outputs* are of open collector type. An output can switch a maximum load of 100mA at 30V. Any device to be controlled by the GPI outputs (lamp, LED or similar) needs to be connected to an external supply voltage on one end and to the GPI output on the other end.

Warning! Do not connect external supply voltages higher than 30V DC.

7 Control Panel operation

All local control panels are completely configurable with the System Configurator, which is downloadable from the Support pages at <http://www.nevion.com/>

All local control panels are given a default configuration, which includes the buttons “A/V Toggle”, “Panel Enable”, “Take on/off” and “Take”. In addition input and output buttons are preconfigured.

The extra buttons on the 2RU and 4RU panels are not preconfigured. They may be configured by the user.

Note that GPI functions are *not* programmable on Sublime GPI CP's. They have a fixed, preconfigured function, described earlier in Chapter 3.

7.1 Button description

7.1.1 A/V Toggle

The A/V Toggle button enables/disables audio and video on a specified address. The address can either be read from the dip switches, or be fixed. The button toggles between three states.

The user may program more than one A/V Toggle buttons; one button for each router level that the user wants to control. See Chapter 5.2.1 and the *Nevion Configurator User Manual* for further details.

If the button is pressed for more than 1 second, it will go into a fourth state where both audio and video are disabled.

In this state the button will be dimmed. If the button is pressed for more than 1 second again, it will enable both audio and video if present.

Button Color	Video Enabled	Audio Enabled
Yellow	Yes	Yes
Green	Yes	No
Red	No	Yes
Dimmed	No	No

If neither audio nor video is present, it will be marked as disabled and the toggle state will not be used.

Toggle status changes will be stored in flash and used when the panel is powered up later.

The following information is only valid for Sublime FW version 2.5.3 and older:

If neither audio nor video is present, it will be marked as disabled and the toggle state will not be used.

When a panel is powered on it will search for connected routers. If no routers are found the A/V Toggle button will be disabled (no light in the button).

This can happen if the panel is powered up before any routers are connected or if there is something wrong with the cabling.

To re-enable the A/V Toggle do the following:

1. Activate the *Panel Enable* button (Green light).
2. Push & Hold the A/V Toggle-button for 2 seconds.

The A/V Toggle-button should now be activated and the light turned on.

7.1.2 Panel Enable

The panel always starts in disabled mode. In this state the button will be red and all the other buttons will be disabled. When pressing the button the panel will be enabled and the color will change to green. A status request will also be sent to get information on active levels.

7.1.3 Take on/off

The Take on/off button enables or disables the Take button. If no take button is defined, Take on/off is always off. On first start-up the take button is enabled. Later it will read the last status from the flash memory.

Activating a GPI I/O will not influence the Take on/off function, nor will a Take on/off function influence the activation of a GPI I/O function.

7.1.4 Take

The Take buttons LED is normally off. If the Take on/off button is set to “on”, no commands will be sent from the panel until the Take button is pressed. The last selected buttons and the take button will blink, until the Take button is pressed and the command is sent from the panel.

Activating a GPI I/O will not influence the Take function, nor will a Take function influence the activation of a GPI I/O function.

7.1.5 Output

An Output button is used for selecting an output. Selecting an output activates it, so that it is switched to the next input that is selected.

7.1.6 Input

An Input button switches the active output to the selected input. If the Take button is enabled, the switch will not be executed until the Take button is pressed.

When switching using the Input button, all enabled audio- and video-levels will be switched from the selected input to the active output.

Note that, unlike the buttons on the front of the panel, GPI inputs 1-32 cannot be reconfigured to represent other inputs, i.e. they are fixed inputs (1-32), operating on the selected output.

7.1.7 XY

An Input to Output (XY) button switches a preset input to a preset output on all enabled audio- and video-levels. If the Take button is enabled, the switch will not be executed until the Take button is pressed.

The maximum router size(s) that may be controlled without Multicon is formed by IN#1-128 and OUT#1-64 (router size: 128x64). This size limitation is regardless of the number of routers the control panel(s) is/are controlling.

See also the limitations 1 and 2 in Chapter 5.2.1.

7.1.8 Salvo

A Salvo button switches a sequence of cross points. This is done even if the specified audio- or video-level is disabled.

The following limitations on the number and size of salvos in *Sublime external CP's* apply:

- Maximum 4 levels (audio + video), each up to 128 X-points;
- Maximum 20 salvos of max. 64 X-points.

The following limitations on the number and size of salvos in *Sublime local CP's* (included in router) apply:

- Maximum 1 level (audio + video), up to 128 X-points;
- Maximum 20 salvos of max. 64 X-points.

7.1.9 Lock

A Lock Toggle button toggles the lock-status on the active output on all enabled audio- and video-levels. If the active output on any of the enabled levels is locked before pressing the button, they will be unlocked. If not the active output on all enabled levels will be locked. A locked output can't be switched.

7.1.10 Protect

A Protect Toggle button toggles the protect-status on the active output on all enabled audio- and video-levels. If the active output on any of the enabled levels is protected before pressing the button, it will become unprotected. If not, the active output on all enabled levels will be protected. A protected output can't be switched by anyone else but the user that protected it.

General environmental requirements for Nevion equipment

1. The equipment will meet the guaranteed performance specification under the following environmental conditions:
 - Operating room temperature range: 0°C to 45°C
 - Operating relative humidity range: <95% (non-condensing)

2. The equipment will operate without damage under the following environmental conditions:
 - Temperature range: -10°C to 55°C
 - Relative humidity range: <95% (non-condensing)

Product Warranty

The warranty terms and conditions for the product(s) covered by this manual follow the General Sales Conditions by Nevion, which are available on the company web site:

www.nevion.com

Important notes regarding Software in the VikinX Sublime router family range

This product utilizes software components that are licensed with open source licenses. The source code for these components and our modifications are available from: <http://labs.nevion.com/open-source/>

OpenTCP includes software developed by Viola systems (<http://www.violasystems.com/>).

Appendix A Materials declaration and recycling information

A.1 Materials declaration

For product sold into China after 1st March 2007, we comply with the “Administrative Measure on the Control of Pollution by Electronic Information Products”. In the first stage of this legislation, content of six hazardous materials has to be declared. The table below shows the required information.

組成名稱 Part Name	Toxic or hazardous substances and elements					
	鉛 Lead (Pb)	汞 Mercury (Hg)	鎘 Cadmium (Cd)	六价铬 Hexavalent Chromium (Cr(VI))	多溴联苯 Polybrominated biphenyls (PBB)	多溴二苯醚 Polybrominated diphenyl ethers (PBDE)
All products referred to in Chapter 1.1	○	○	○	○	○	○
SL-PWR-40	○	○	○	○	○	○
O: Indicates that this toxic or hazardous substance contained in all of the homogeneous materials for this part is below the limit requirement in SJ/T11363-2006.						
X: Indicates that this toxic or hazardous substance contained in at least one of the homogeneous materials used for this part is above the limit requirement in SJ/T11363-2006.						

This is indicated by the product marking:



A.2 Recycling information

Nevion provides assistance to customers and recyclers through our web site <http://www.nevion.com/>. Please contact Nevion’s Customer Support for assistance with recycling if this site does not show the information you require.

Where it is not possible to return the product to Nevion or its agents for recycling, the following general information may be of assistance:

- Before attempting disassembly, ensure the product is completely disconnected from power and signal connections.
- All major parts are marked or labeled to show their material content.
- Depending on the date of manufacture, this product may contain lead in solder.
- Some circuit boards may contain battery-backed memory devices.