

A decorative graphic at the top of the page consisting of two overlapping wave-like patterns of dots. The upper wave is composed of green dots, and the lower wave is composed of blue dots. Both waves start on the left and curve towards the right.

Multicon User Manual

Revision: N

2016-01-15

Contents

1	Nevion Support	6
2	History	7
3	Product Overview	8
3.1	Introduction	8
3.1.1	Product Offering	9
3.1.2	Licensed Features	9
4	System Architecture	11
4.1	Flashlink	11
4.2	VikinX Sublime	12
4.3	VikinX Modular	13
5	Specifications	16
5.1	Web Interface	16
5.2	Protocols	16
5.2.1	Control Protocols	16
5.2.2	SNMP	17
5.2.3	Configuration Protocol	18
5.2.4	Spread Communication	18
5.3	Performance	18
5.3.1	Number of Flashlink Cards	18
5.3.2	Number of VikinX Devices	18
5.3.3	Number of Web Clients	18
5.3.4	Total Capacity per Multicon System	19
5.4	Front View	19
5.5	Rear View	20
5.6	Hardware Specifications	21
6	Operation	23
6.1	IP Configuration	23
6.1.1	Change from Web Interface	23
6.1.2	Change using Nevion Configurator	24
6.2	System Concept	25
6.2.1	Creating a System from the Web Interface	25
6.2.2	Creating a System using Nevion Configurator	26
6.3	License Keys	28
6.4	Firewall Configuration	29
7	Web Interface	30

7.1	General	30
7.2	Alarms Page	31
7.3	Log Page	32
7.4	Config Page	33
7.4.1	User and Access Setup	33
7.4.2	Date and Time	35
7.4.3	Flashlink	36
7.4.4	Debug Terminal	36
7.4.5	SNMP Setup	36
7.4.6	Maintenance	38
7.5	Manuals	38
8	Flashlink Web Interface	39
8.1	Flashlink Sub-system View	39
8.2	Flashlink Module View	39
8.2.1	Information Page	40
8.2.2	Configuration Page	41
8.2.2.1	Card Label	41
8.2.2.2	Advanced Configuration	42
8.2.2.3	Matrix Configuration	42
8.2.2.4	Alarm Configuration	43
8.2.2.5	Passive Modules	44
8.3	Multicon Module View	44
8.4	Flashlink Maintenance	46
8.4.1	Frame configuration	46
8.4.2	Frame Labels	47
8.4.3	Card Configurations	47
8.4.3.1	Transfer System Configurations	48
8.5	Debug Terminal	48
8.6	Flashlink Firmware Upgrade	49
8.6.1	Transfer Firmware Files to Multicon	50
8.6.2	Micro Controller Upgrade Process	50
8.6.3	FPGA Upgrade Process	51
9	Web Control Interface	53
9.1	List View	53
9.2	Matrix View	55
9.3	Salvo View	56
10	System Overview	58
11	Software Upgrade	59
11.1	Introduction	59
11.1.1	GYDA-SC Upgrade	59
11.1.2	ETH-CON and SYSCON Upgrade	60

11.2	Upgrade from GYDA-SC, ETH-CON and SYSCON to Multicon	60
11.3	Upgrade Procedure for Multicon	60
11.3.1	Using Nevision Configurator	60
11.3.2	Using Multicon Web Interface	62
12	Hardware Information	63
12.1	Housing	63
12.2	Status LEDs	64
12.3	How to Access the Module	66
12.4	Card Insertion and Removal	66
12.5	Storage	67
12.5.1	CF card (Mk2 only)	67
12.5.2	MicroSD card (Mk4 only)	67
12.6	Battery (Mk2 only)	68
12.7	Reset Button (Mk2 only)	68
12.8	DIP switches (Mk4 only)	69
12.8.1	Factory default procedure	69
12.9	Flashlink Card Hot Swap	70
12.10	Back Plane Connectors	70
12.10.1	Hardware revision 2	70
12.10.2	Hardware revision 4 without SFP	71
12.10.3	Hardware revision 4 with SFP	72
12.11	GPIO	73
12.11.1	Connections (mk2)	73
12.11.2	Connections (mk4)	74
12.12	Monitor Flashlink Power Supplies (mk2)	75
12.13	Serial Connectivity	75
12.13.1	DB9 connectors	76
12.13.2	Molex KK 254 5pin connectors	76
12.13.3	Maximum Cable Length (RS-232)	76
12.14	Ethernet Connectivity	76
12.14.1	Ethernet connections on Mk4	77
12.15	External RS422 Flashlink Connectivity	77
A	Protocol Specifications	79
A.1	Modular Router Protocol (MRP)	79
A.2	NCB Sublime/Compact	79
A.3	SNMP	79
A.4	Snell Pro-bel SW-P-02	79
A.5	Leitch Pass-Through	80
A.6	Triton	82
A.7	Thomson/Grass Valley Native	82
A.8	TSL UMD Protocol	84

B	General Environmental Requirements for Nevion Equipment	85
C	Product Warranty	86
D	Materials Declaration and Recycling Information	87
D.1	Materials Declaration	87
D.2	Recycling information	87
E	EC Declaration of Conformity	88

1 Nevion Support

Nevion Europe

P.O. Box 1020

3204 Sandefjord, Norway

Support phone 1: +47 33 48 99 97

Support phone 2: +47 90 60 99 99

Nevion USA

1600 Emerson Avenue

Oxnard, CA 93033, USA

Toll free North America: (866) 515-0811

Outside North America: +1 (805) 247-8560

E-mail: support@neviON.com

See <http://www.neviON.com/support/> for service hours for customer support globally.

2 History

Revision	Date	Author	Comments
M	2016-01-14	JGS	Updated Flashlink webinterface descriptions
M	2015-10-27	AAA	Info about Multicon with SFP added
L	2015-06-04	JGS	Updated dip switch info and factory reset procedure
K	2015-01-09	JGS/JIH	Updated with info about hardware version 4
J	2013-10-31	JIH	Updated for release 4.0
H	2013-09-03	JGS/JIH	Added new protocol info for release 3.8
G	2012-12-17	JGS	Updated revision info
6	2012-10-01	JIH	Info about external RJ45 connection
5	2012-09-07	JGS	Updated text describing upgrade possibilities.
4	2011-04-27	JIH	Added performance data in Chapter 3.6.
3	2011-01-03	JIH	Added alert box in Chapter 2.2.
2	2010-09-15	JIH	Updated GYDA user management (Chapter 5.5.1).
1	2009-12-30	JIH	Consolidated all manuals
0	2009-07-02	JIH	First official release

3 Product Overview

3.1 Introduction

The Multicon product provides fully integrated state-of-the-art element management and system control capabilities for Flashlink and VikinX systems. Multicon supports a wide range of applications ranging from optical network monitoring and configuration to router control.

The Multicon product provides element management and system control capabilities for Flashlink and VikinX systems. The software may be licensed to support different applications and is available in different product packages to support the main applications.

Multicon includes interfaces for web-based monitoring and control, hardware and software control panels, automation systems and SNMP-based network management systems. The software also supports control of third-party devices using industry standard protocols.

The Multicon software is running on a dedicated hardware card that may be installed in Flashlink, Flashcase, N-BOX or VikinX Modular frames. Multicon is typically installed in an N-BOX to support Flashlink Compact and Sublime devices.

Multicon is the second generation system controller from NeviON replacing the former GYDA-SC, ETH-CON and Syscon products. Multicon is based on an open and distributed architecture and provides one platform to monitor and control both Flashlink and VikinX products. These features and a powerful third party plug-in interface allow for full control of the entire video transport chain.

The latest range of Flashlink SP&D cards have a large number of parameters that may require modification in a production environment. Multicon provides the solution for easy access to control SP&D parameters from control panels or automation systems. This new feature allows the user to modify SP&D parameters like scaling, pan and zoom from control panels during operation of the card.

The following key features are provided by Multicon:

- User-friendly web GUI for monitoring, configuration and control of Flashlink and VikinX
- Support for up to 80 Flashlink cards
 - Status information and card configuration
 - Hot-swap of cards
 - Remote firmware upgrade
- Support for VikinX Sublime, Compact and Modular
 - Level control, virtual routing and salvos
 - System with multiple controllers
- Integration with hardware and software control panels
- Alarm management and forwarding

- SNMP support for monitoring and configuration
- Third-party router integration (Leitch, GVG and Pro-bel)

3.1.1 Product Offering

Main product based on Multicon hardware revision 4:

Sales product	Description	Hardware
MCON-HW-MK4	Main board and backplane only Requires software licenses	Used for Flashlink and Sublime systems

Main product based on Multicon hardware revision 2:

Sales product	Description	Hardware
Multicon VX-MOD	Web, Control Panel and SNMP interface for - Modular router (64/128/256) - 32 Sublime/Compact routers	For use with VikinX Modular only

3.1.2 Licensed Features

The Multicon software is the same for all products but the features are controlled by licenses. The table below shows the licenses included with each product offering. It is possible to add additional features by adding licenses to a Multicon controller.

Licenses for Multicon hardware revision 4:

Sales product	Description
MCON-SW-FL-10	Multicon license for 10 Flashlink cards (1 frame)
MCON-SW-FL-80	Multicon license for 80 Flashlink cards (8 frames)
MCON-SW-VX-SL	Multicon license for Sublime routers
MCON-SW-WCTRL	Multicon license for web-based router control
MCON-SW-3PP	Multicon license for third-party protocols

Licenses for Multicon hardware revision 2:

Sales product/ Licensed features	Multicon GYDA-ONE	Multicon GYDA	Multicon VX-SLC	Multicon VX-MOD
Multicon OPT-GYDA-ONE: Flashlink support for one (1) frame	Included	Included	Option	Option

Sales product/ Licensed features	Multicon GYDA-ONE	Multicon GYDA	Multicon VX-SLC	Multicon VX-MOD
Multicon OPT-GYDA: Flashlink support for up to eight (8) frames	Option	Included	Option	Option
Multicon OPT-VX-SLC: VikinX Sublime/Compact support	Included	Included	Included	Included
Multicon OPT-VX-MOD: VikinX Modular support	Option	Option	Option	Included
Multicon OPT-TRITON: Triton protocol support	Included	Included	Included	Included
Multicon OPT-PROBEL: Pro-bel SW-P-02 protocol	Option	Option	Option	Included
Multicon OPT-LEITCH: Leitch pass-through protocol	Option	Option	Option	Option
Multicon OPT-GVG: Grass Valley/Thomson protocol support	Option	Option	Option	Option
Multicon OPT-WC: Web control interface	Option	Option	Option	Option
Multicon OPT-3PP: Third-party plug-in support	Option	Option	Option	Option

4 System Architecture

Figure 4.1 below illustrates the Multicon architecture. The Multicon controllers may be fitted either in Flashlink frames, N-BOX housing or in the VikinX Modular frame.

All Multicon controllers provide a Web interface on HTTP port 80 and a Control Panel interface on MRP port 4381. The controllers also exchange status information using the TCP/IP based MBUS protocol (for internal use between controllers only and not visible externally).

Using the third-party SDK it is also possible to integrate with other TCP/IP hosts and clients. Host devices are typically automation systems or third-party control systems that shall control Multicon while client devices shall be controlled by Multicon.

Each Multicon controller provides two RS-232/RS-422 serial ports for connection of VikinX Compact routers or third-party devices that communication over serial.

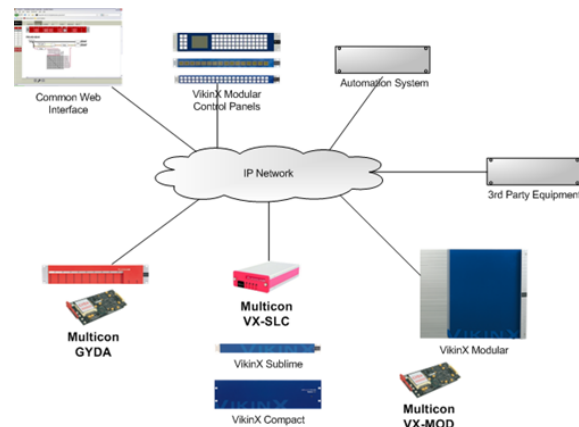

Figure 4.1 Multicon system architecture

Note that in the figure Multicon GYDA is the product for Flashlink monitoring and control, Multicon VX-SLC is the product for VikinX Sublime and Multicon VX-MOD is the product for VikinX Modular. With hardware revision 4 of Multicon, there are no longer separate products for Multicon GYDA and VX-SLC, but the same Multicon product may be licensed to support either Flashlink, VikinX Sulime or both.

4.1 Flashlink

For Flashlink it is necessary to have one Multicon in each Flashlink sub-system which may consist of up to eight (8) frames. Note that if there is a separate license that supports only one (1) frame.

Figure 4.2 shows how you can interface with one Flashlink sub-system using the Web interface and Control Panels. The Web interface uses the W3C standard HTTP protocol and the Control Panels use the Nevion MRP protocol.

It is possible to combine several Flashlink sub-systems into one Multicon system as illustrated in **Figure 4.3**. In this simple example you can use the same Web interface and Control Panels to manage modules in both Flashlink sub-systems.

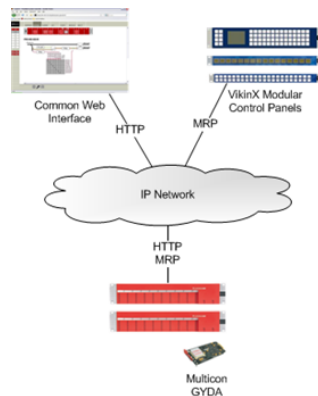

Figure 4.2 Multicon for one Flashlink sub-system

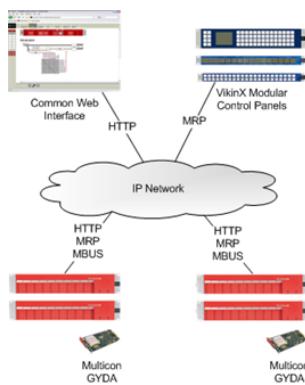

Figure 4.3 Multicon for multiple Flashlink sub-systems

The Multicon controllers communicate internally over the Nevion MBUS protocol to exchange status information and perform settings across physical controllers (for internal use between controllers only and not visible externally).



system.

Note: As a design rule it is recommended to keep the Multicon systems as small as possible, i.e. place only equipment that needs to be managed from the same Web interface and Control Panels into the same Multicon

4.2 VikinX Sublime

Multicon is used to control VikinX Sublime, Compact and 3rd party routers. Multicon is also used as an interface between VikinX Sublime/Compact routers and Control Panels.

Figure 4.4 shows how to use Multicon to control a VikinX Sublime router over TCP/IP and a VikinX Compact router over the Network Control Bus (NCB) via a RS-232 connection to the router.

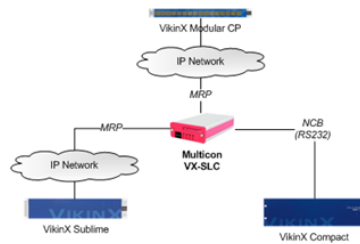

Figure 4.4 Multicon for VikinX Sublime and Compact

Figure 4.5 shows how to deploy redundant controllers for control of a VikinX Sublime and Compact router. The two Multicon controllers communicate via an internal MBUS protocol. If one controller fails the other controller will take over as main controller for the routers. The control panels will also switch over to the other controller.

The Multicon controllers communicate internally over the NeviON MBUS protocol to exchange status information and perform settings across physical controllers.

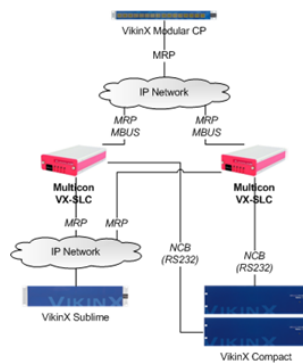

Figure 4.5 Redundant Multicon for VikinX Sublime and Compact

 **Note:** Sublime control panels can only have one connection to a controller, which means that it is not possible to use Sublime control panels with two redundant Multicon controllers. If redundancy is required it is necessary to use VikinX Modular control panels instead.

Figure 4.6 shows how to control a Pro-bel router and a Triton router from a Multicon controller. Multicon communicates with the routers using SW-P-02 serial line protocol and Triton Protocol.

4.3 VikinX Modular

Multicon VX-MOD is used to control VikinX Modular routers but also comes with support for VikinX Sublime, Sublime Compact and Compact routers. In addition, the product may be controlled by or control devices using the Pro-bel SW-P-02 protocol. Optionally it is also possible to extend the protocol support with other third-party protocols.

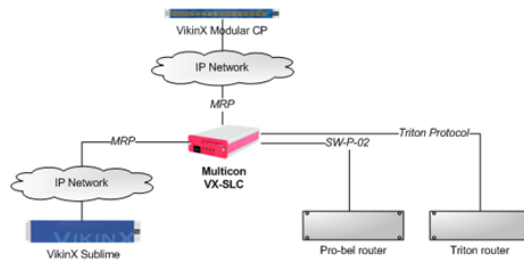

Figure 4.6 Multicon control of third-party routers

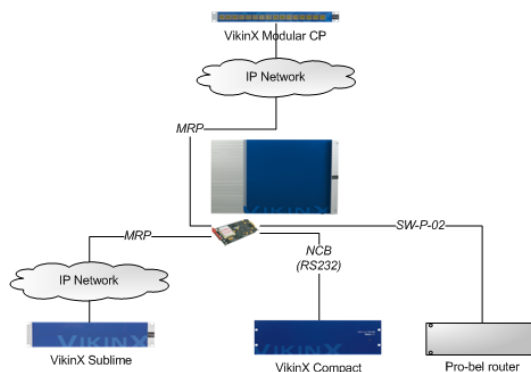

Figure 4.7 Multicon VX-MOD for VikinX Modular, Sublime and third-party control

The following examples show possible ways to use Multicon VX-MOD in combination with VikinX, Flashlink and Pro-bel routers.

Figure 4.7 shows how to use Multicon VX-MOD together with VikinX Sublime, Compact and Pro-bel routers. The Sublime router is connected via TCP/IP (Modular Router Protocol), while the Compact and Pro-bel routers are connected via serial line interface.

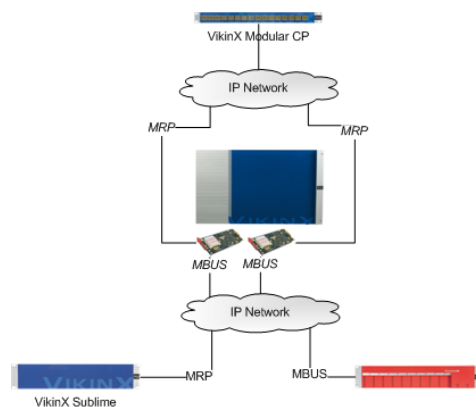

Figure 4.8 Multicon for VikinX Modular and Sublime control in a system with a Multicon for Flashlink control

Figure 4.8 shows how to use Multicon VX-MOD together with VikinX Sublime and a Flashlink system with Multicon GYDA. The Sublime router is connected via TCP/IP using the Modular Router Protocol, while Multicon for Flashlink (in the Flashlink frame) is connected via TCP/IP using the MBUS protocol between Multicon controllers.

The two redundant Multicon controllers in the Modular frame have to communicate internally to exchange state information using the MBUS protocol over the external IP network (for internal use between controllers only and not visible externally).



Note: Redundant Multicon controllers always have to be reachable over an external IP network.

5 Specifications

5.1 Web Interface

The Multicon web interface is supported for the following browser versions:

- Firefox version 25 or higher
- Internet Explorer 10 or higher
- Chrome version 30 or higher



Note: Multicon 4.0 and newer uses web socket technology that requires an updated browser version.

5.2 Protocols

5.2.1 Control Protocols

Multicon supports various control protocols for northbound communication (referred to as host protocols) and southbound communication (referred to as client protocols). Host protocols are typically used for integrating with control panels and external systems like automation. Client protocols are used for integrating with devices such as routers and terminal gear.

Multicon uses the Modular Router Protocol (MRP) over TCP/IP as its default protocol for northbound (host) and southbound (client) access. The protocol is open for third-party integration and the specification is available as a separate manual document.

Supported northbound (host) protocols:

- MRP (IP)
- NCB Compact (serial)
- NCB Sublime (serial)
- SNMP (IP)
- Thomson/Grass Valley Native (IP and serial)
- Leitch PassThru (IP and serial)
- Pro-Bel SW-P-02 (IP and serial)
- Triton (serial)

Supported southbound (client) protocols:

- MRP (IP)
- NCB Compact (Serial)
- NCB Sublime (Serial)
- Thomson/Grass Valley Native (IP and serial)
- Leitch PassThru (IP and serial)
- Pro-Bel SW-P-02 (IP and serial)
- Triton (serial)

This list is valid for Multicon firmware 3.8.0 (or newer). To configure a Multicon system with these protocols also requires Nevion Configurator 4.4.0 (or newer).

Further information concerning the level of support for each protocol is provided in [Appendix A](#).



Note: Note that the availability of these protocols depends on the licensing of the Multicon product.

5.2.2 SNMP

Multicon supports SNMP version 1, 2c or 3 over UDP, following SMI version 2.0 according to relevant RFCs.

RFC1157

Case, J., M. Fedor, M. Schoffstall and J. Davin, "The Simple Network Management Protocol", STD 15, RFC 1157, May 1990.

RFC2578

McCloghrie, K., Perkins, D. and J. Schoenwaelder, "Structure of Management Information Version 2 (SMIv2)", STD 58, RFC 2578, April 1999.

RFC1901

The SNMPv2 Working Group, Case, J., McCloghrie, K., Rose, M. and S. Waldbusser, "Introduction to Community-based SNMPv2", RFC 1901, January 1996.

RFC2574

Blumenthal, U. and B. Wijnen, "The User-Based Security Model for Version 3 of the Simple Network Management Protocol (SNMPv3)", RFC 2574, April 1999.

The following security features are supported:

- User defined community strings (v1 or v2c)
- User based Security Model (v3 only)
- Possible to turn off v1/v2c support.

All alarms are sent as SNMP traps with user selectable filtering.

5.2.3 Configuration Protocol

Multicon uses Device Configuration Protocol (Nevion proprietary) over TCP/IP for setup of the system. The protocol is only used internally between the Nevion Configurator and Multicon.

5.2.4 Spread Communication

This product uses software developed by Spread Concepts LLC for use in the Spread toolkit. For more information about Spread see <http://www.spread.org>.

The Spread interface is used for internal communication between Multicon controllers and provides a highly reliable communication mechanism.

5.3 Performance

5.3.1 Number of Flashlink Cards

The following number of Flashlink cards are supported per Multicon card:

- 10 Flashlink cards maximum with single-frame license
- 80 Flashlink cards maximum with multi-frame license

5.3.2 Number of VikinX Devices

The following number of VikinX devices (routers and control panels) are supported per Multicon card:

- Total of 32 devices (routers and control panels) when the Multicon card is NOT used for Flashlink
- Total of 8 devices (routers and control panels) when the Multicon card is also used for Flashlink

5.3.3 Number of Web Clients

The following number of web clients are supported per Multicon card:

- Total of 10 web clients when the Multicon card is NOT used for Flashlink
- Total of 5 web clients when the Multicon card is also used for Flashlink

5.3.4 Total Capacity per Multicon System

The following specifies total capacity per Multicon system:

- Total number of levels (video and audio) in a system should be less than 200
- Total number of control panels in a system should be less than 64
- Total number of crosspoints (in all levels) in a system should be less than 5000
- Total number of virtual routers in a system should be less than 10 with a maximum of 256 crosspoints in each virtual router
- Total number of salvos in a system should be less than 100 with a maximum of 256 settings in each salvo

Please contact NeviON Support to discuss system configuration options if your planned system exceeds the total capacity above.

5.4 Front View

Figure 5.1 shows the front-view of Multicon Mk2.

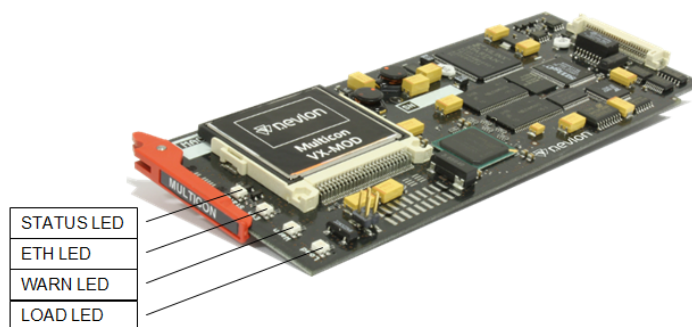

Figure 5.1 Front-view Mk2

Figure 5.2 shows the front-view of Multicon Mk4.

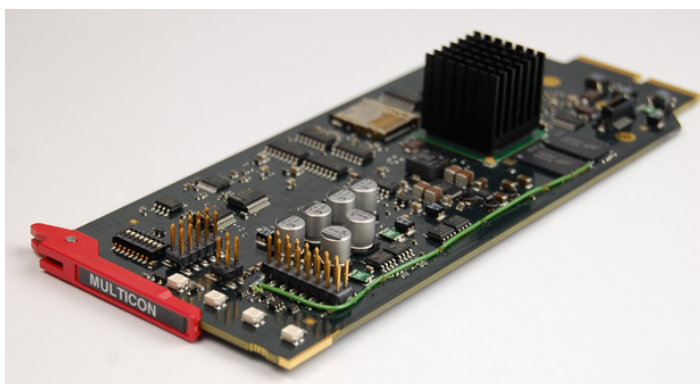

Figure 5.2 Front-view Mk4

5.5 Rear View

Figure 5.3 shows the rear-view connectors and their function for Multicon Mk2.

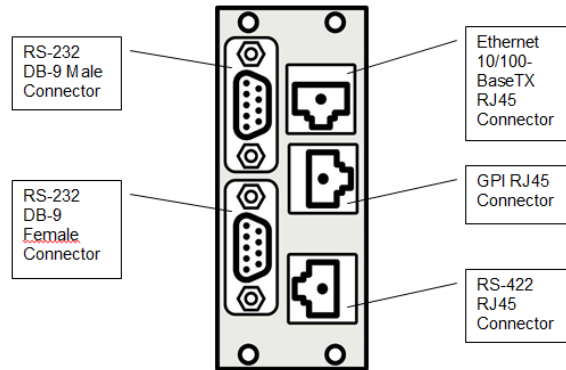

Figure 5.3 Rear-view Mk2

Figure 5.4 shows the rear-view connectors and their function for Multicon Mk4 without SFP.

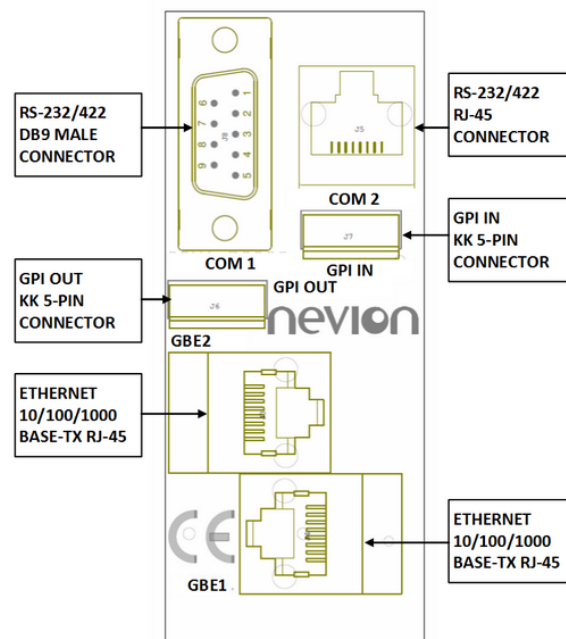

Figure 5.4 Rear-view Mk4 without SFP

Figure 5.5 shows the rear-view connectors for Multicon Mk4 with SFP.

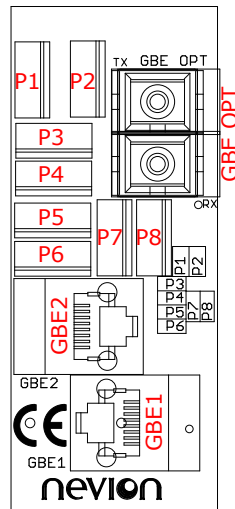

Figure 5.5 Rear-view Mk4 with SFP

5.6 Hardware Specifications

The following specifications apply for controller hardware versions 2 and 4.

Component	Version 2 (Mk2)	Version 4 (Mk4) without SFP	Version 4 (Mk4) with SFP
CPU	400MHz StrongARM PXA255	533MHz DualCore PowerPC e500v2 P1025	533MHz DualCore PowerPC e500v2 P1025
Memory	64MB SDRAM 8MB on-board Flash Compact Flash card	512MB 32bit DDR3 SDRAM 2MB on-board Flash MicroSD card	512MB 32bit DDR3 SDRAM 2MB on-board Flash MicroSD card
RS-232/ RS-422	3 x COM ports Connectors DB9M, DB9F, RJ-45 IBM PC TIA-574 (RS-232) SMPTE 207M (RS-422) 8P8C TIA-561 (RJ-45)	2 x COM ports Connectors DB9M, RJ-45 IBM PC TIA-574 (RS-232) SMPTE 207M (RS-422) 8P8C TIA-561 (RJ-45)	2 x COM ports Connectors Mulex KK 254 5pin IBM PC TIA-574 (RS-232) SMPTE 207M (RS-422)
Ethernet	1 x 10BaseT / 100BaseTX Full duplex	2 x 10BaseT / 100BaseTX / 1000BaseT Full duplex	2 x 10BaseT / 100BaseTX / 1000BaseT 1 x 1000BaseX Full duplex
Ethernet switch bandwidth		400 Mbits/sec	400 Mbits/sec
Power	+5V DC, 3W	+5V DC, 7W	+5V DC, 7W



Note: Multicon requires controller hardware version 2 (Mk2) or version 4 (Mk4). It cannot run on controller hardware version 1 (Mk1).

6 Operation

This chapter describes operational preparations that are required before the Multicon controller may be used to monitor and control Flashlink, VikinX Sublime or Modular sub-systems. The preparations described here are common for all Multicon controllers and involves use of the Nevion Configurator.

This is not a complete guide to setting up Multicon systems using the Nevion Configurator, but limited to the preparations required to start using your Multicon controller. Please refer to the Nevion Configurator online help for more detailed information about configuring Multicon systems.

6.1 IP Configuration

6.1.1 Change from Web Interface

Multicon 4.0 and newer supports changing the IP address from the web interface. This will also automatically create a system as described in [Section 6.2](#) and provides an easier way to get started using the Multicon controller.

To change the IP address from the web interface perform the following steps:

1. Connect a laptop directly to the Ethernet port of the Multicon controller.
2. Configure the laptop to use the IP address 192.168.0.11 and netmask 255.255.255.0.
3. Open a supported web browser and go to <http://192.168.0.10>.
4. Select the Config tab and click on Network which presents the page shown in [Figure 6.1](#).
5. Set the hostname as required.
6. Set the IP address, netmask and default gateway to match the network configuration.
7. Click on Update.

The default IP address 192.168.0.10 above is set for all new cards delivered by Nevion. If the IP address has been changed previously for the card, then this address will have to be used. If the IP address is not known then the Nevion Configurator may still be used to set a new IP address.



Note: Changing the network settings will trigger a reboot of the Multicon controller.



Note: Changing IP address from the web interface is only possible if the controller is not yet added to a system or is in a system with only one controller. If multiple controllers are present in the system, the Nevion Configurator must be used to set a new IP address.

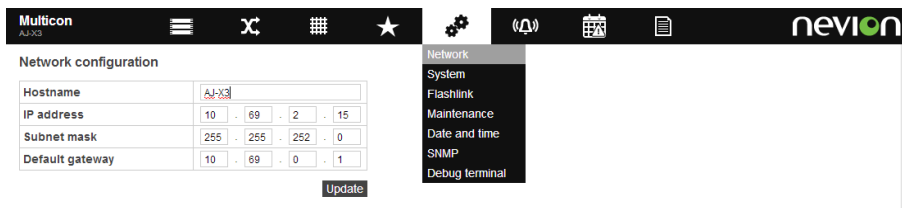

Figure 6.1 Web interface network settings

6.1.2 Change using Nevision Configurator

This section describes how to change the IP address of the Multicon controller using the Nevision Configurator. The same procedure is applicable for changing IP configuration for control panels and routers. The IP configuration procedure is described in detail below:

1. Open the Nevision Configurator.
2. Select a system to open or click cancel. Note that it is not necessary to open a system to perform IP configuration.
3. Go to Tools -> IP settings from the menu bar.
4. Select the appropriate filter from the drop down.
5. Current system only will only show devices in the currently open system.
6. All systems will show all devices detected by the Nevision Configurator grouped per system.
7. Device types will show all devices grouped by device type.

Hostname	IP address	Subnet mask	Default gateway	Firmware	Mac	Info
System: COLL_DEMO						
Type: MULTICON						
Demo_MC_QYDA	192.168.110.50	255.255.255.0	192.168.110.1	3.3.0	00:0D:39:01:04:5A	
System: COLL_FR1						
Type: MULTICON						
Coll_FR1_MULTICON	192.168.110.10	255.255.255.0	192.168.110.1	3.3.0	00:0D:39:01:06:17	
Type: SUBLINE DEVICES						
SL-AD1616-CP_1	192.168.110.13	255.255.255.0	192.168.110.1	1.0.5	00:0D:39:0A:02:E3	MRP (TCP) - CP, R, DIP 1
SL-SD1616-CP_1	192.168.110.14	255.255.255.0	192.168.110.1	1.0.5	00:0D:39:0A:03:D4	MRP (TCP) - CP, R, DIP 2
System: SYSTEM1						
Type: CONTROL PANELS						
44MEC_FR1	192.168.110.16	255.255.255.0	192.168.110.1	3.1.1	00:0D:39:02:01:7D	1 MEC, DIP 1, Master
System: SYSTEM4						
Type: SUBLINE DEVICES						
SL-CP_2	192.168.110.22	255.255.255.0	192.168.110.1	1.0.5	00:0D:39:0A:02:49	MRP (TCP) - CP, DIP 2

Figure 6.2 Nevision Configurator device list

1. Select the device you want to modify the IP configuration for and enter correct IP configuration settings.
2. Click OK at the bottom of the window.



Note: The IP configuration for the Multicon controllers **MUST** be done using the Nevision Configurator. It is **NOT** possible to modify IP address settings by modifying files on the CF-card directly.

6.2 System Concept

It is necessary to include all Multicon controllers in a system using the Nevision Configurator. A system is a collection of devices and user configuration. It is the user that defines the system and how it's configured.

Multicon is the system controller handling the system and all communication between devices in the system.

In a system there can be control panels (Modular or Sublime), router sub-systems (Modular, Sublime or 3rd party) and Flashlink sub-systems.

The following guidelines apply for configuring systems:

- All devices that needs to be controlled together must be included in the same system
- Devices that do not need to be controlled together should be included in separate systems
- Typically it makes sense to define one system per production studio or outside broadcast van
- For Flashlink fiber transport it may be preferable to define one system per site to reduce inter-site traffic



Note: All Multicon controllers are shipped without a default system. Before using the Multicon the IP address have to be set correctly and it has to be added to a system.

6.2.1 Creating a System from the Web Interface

Multicon 4.0 and newer supports a simplified process for creating systems that consists of only Flashlink and Sublime devices.

When configuring network settings from the web interface, a system is automatically created by the Multicon controller. This system only includes the controller itself. For Flashlink systems no additional steps is required.

It is possible to add Sublime devices to the automatically created system using the following steps:

1. Make sure that IP address settings have been performed correctly for the controller.
2. Using a supported web browser hover over the Config tab and select System.
3. Click on rescan to search for Sublime devices on the local area network (to add remote devices please refer to the Nevision Configurator).
4. A list of available Sublime devices is presented (that is not previously allocated to another system).
5. It is possible to change the Name, IP Address and Level for each device by hovering over the field and clicking the Edit button.
6. Select Yes in the Active column to add a device to the system.

Figure 6.3 illustrates the user interface for configuring a system using the Multicon web interface.

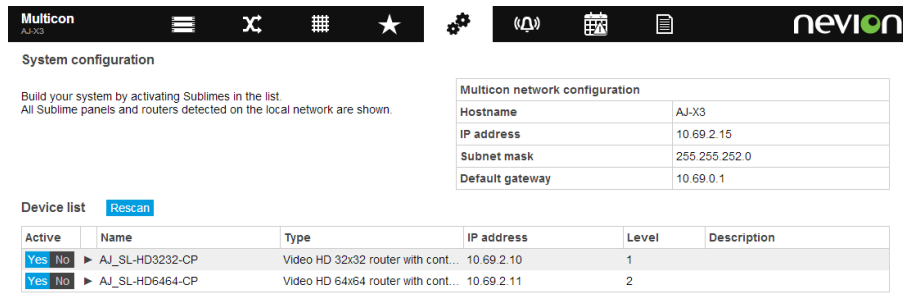

The screenshot shows the Multicon web interface. At the top, there is a navigation bar with the Multicon logo and several icons. Below the navigation bar, the page is titled "System configuration". Underneath, there is a section for "Multicon network configuration" with a table of settings:

Multicon network configuration	
Hostname	AJ-X3
IP address	10.69.2.15
Subnet mask	255.255.252.0
Default gateway	10.69.0.1

Below the network configuration, there is a "Device list" section with a "Rescan" button. It contains a table with the following data:

Active	Name	Type	IP address	Level	Description
Yes No	AJ_SL-HD3232-CP	Video HD 32x32 router with cont...	10.69.2.10	1	
Yes No	AJ_SL-HD6464-CP	Video HD 64x64 router with cont...	10.69.2.11	2	

Figure 6.3 Web interface system settings



Note: Only Sublime devices may be added to a system from the Web interface. In addition, cascaded devices are not supported.

6.2.2 Creating a System using Nevion Configurator

To view the default system configuration you need to do the following:

1. Make sure that the Nevion Configurator is installed on your PC and that the PC is attached to the same subnet where the equipment resides. This is required since the Nevion Configurator uses UDP broadcast to detect systems and devices.
2. If Nevion Configurator is not installed, download and install the application from <http://www.nevion.com/support>.
3. Open Nevion Configurator. A dialog showing detected systems will be shown.
4. Select the system you would like to open, the default system is called System1. Click OK.

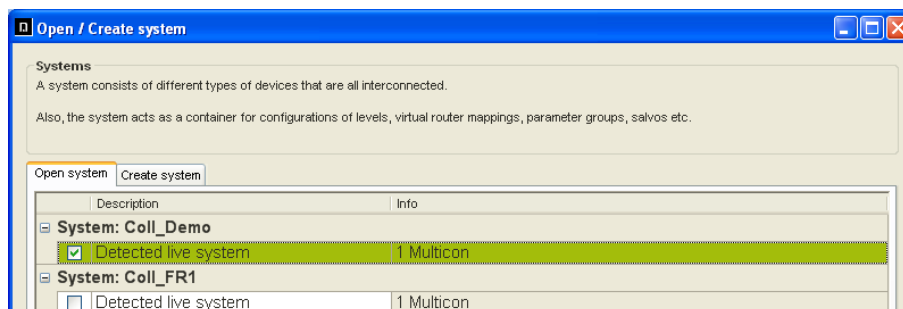

Figure 6.4 Nevion Configurator open system

1. The figure below shows the default system for a Multicon that is controlling a Flashlink sub-system.

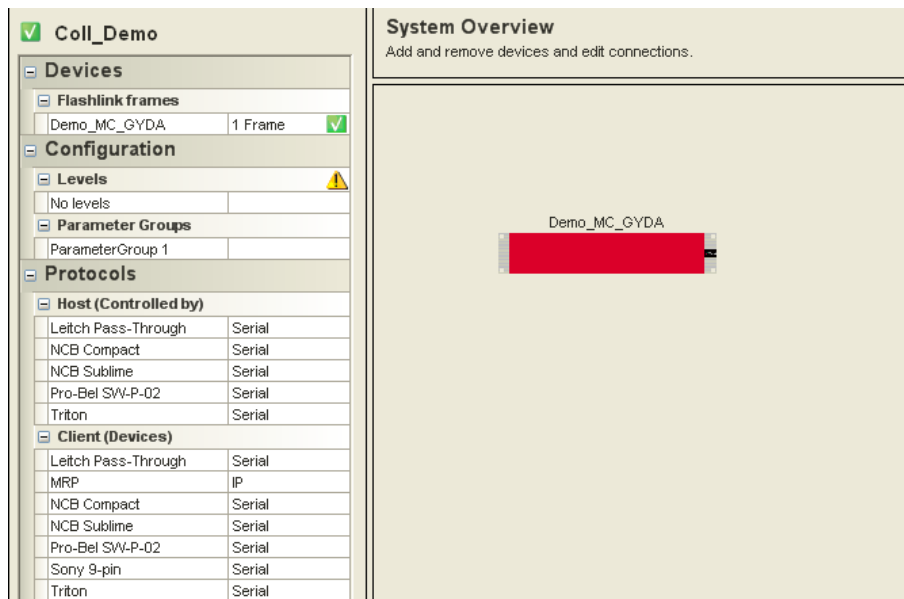

Figure 6.5 NeviON Configurator system overview

If your Multicon controller is not assigned to a system:

1. Open NeviON Configurator. When the Open / create system dialog appears, click the Create system tab.

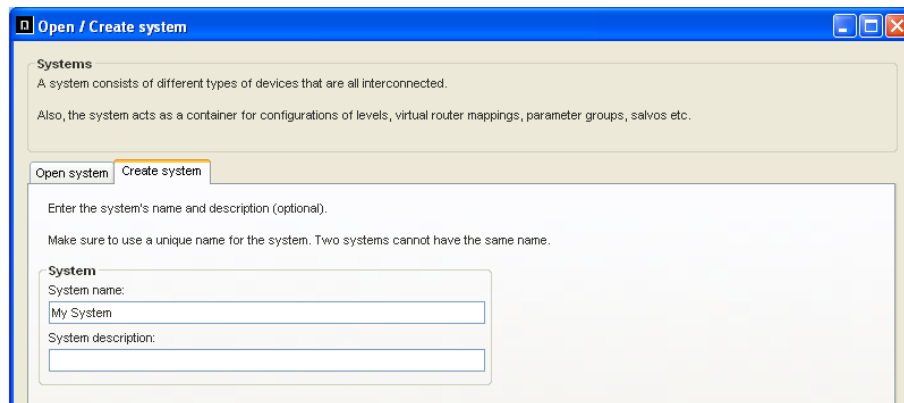

Figure 6.6 NeviON Configurator create system

1. Enter a System name and optionally a System description. Click OK.
2. A new empty system is created. Your Multicon controller should be listed under Unconfigured devices on the left hand side.
3. Select the Multicon controller you want to include in the system and drag it into the system overview.
 1. Click upload from the menu bar. The Multicon controller is added now added as the only device in the system.



Note: Please consult the Nevion Configurator online help for more detailed information about configuration of systems for VikinX routers and control panels.

6.3 License Keys

All Multicon controllers are running the same software and it is the installed license keys that control the available features. It is different license keys that make the controller a Multicon for Flashlink and/or VikinX.

The Nevion Configurator allows you to view the installed license keys and add additional license keys to enable new features.

To manage the installed license keys you need to do the following:

1. Open Nevion Configurator.
2. Select a system to open or click cancel. Note it is not necessary to open a system to manage license keys.
3. Go to Tools -> Product Key Manager from the menu. The following page will appear.

Product Key Manager
Manage your Multicon product keys.

Detected controllers:

Hostname	IP Address	MAC Address	Info
System: Coll_Demo			
Bemo_MC_SYDA	192.168.110.50	00:0D:39:01:04:5A	
System: Coll_FRI			
Coll_FRI_MULTICON	192.168.110.10	00:0D:39:01:06:17	Open system "Coll_FRI" to modify these ke...

Product keys:

Key	Feature Description
4494D1-2E2049-D4E498-80CBFC-987D50-C2D86A	Multicon Flashlink internal protocol (MRP)
54D149-C09BEC-ED5040-46C351-E500BA-AC6894	Multicon Flashlink multi frame
941617-80BFC-C0B9D4-E9B0C4-93904D-EE4980	Multicon MRP client protocol
4494D1-4402E9-C0E498-9097F9-120750-53519C	Multicon MRP host protocol
E52534-492603-6DF6D4-A87D50-46C351-E500BA	Multicon NCB client protocol
54D149-701EF3-C0B9D4-3516C3-4402E9-9634C0	Multicon NCB host protocol
941617-80BFC-84BEA0-6C3516-96108B-9C6890	Multicon Standard
62838B-B4A017-492613-26FD50-D0B5D4-6C3516	Multicon System Overview
762C2E-D0B5D4-253C51-52E940-096293-10BDF6	Multicon Triton client protocol
11494D-E5B0D4-DA500B-626039-9F603D-9592D7	Multicon Triton host protocol

Buttons: New..., Remove, Import from: File..., Clipboard

Figure 6.7 Nevion Configurator product keys

1. Click on a Multicon controller to view the installed license keys.
2. Click New or Import from File to add a new license key for this controller.
3. Click OK.



keys.

Note: It is not possible to add license keys to a Multicon controller that is not included in a system using the Nevion Configurator. Make sure that the controller is added to a system before attempting to modify license

6.4 Firewall Configuration

In order for multiple Multicon controllers and the NeviON Configurator to work, a few select ports must be open. These are described below.

Port 80 is required for communication between the Multicon Web interface and the Multicon controller and must always be open.

Port 2836, 2837 and 2838 are required for communication between Multicon controllers that are configured in the same system.

Port 3972 is required for communication between the NeviON Configurator and Multicon controllers, control panels and routers in the system.

The NeviON Configurator uses broadcast to detect devices and requires that all devices in the system are on the same IP sub-net.

Port 4381 is required for communication between Multicon controllers and control panels and routers in the system.

Port	Type	Description
80	TCP	HTTP traffic from UI to Multicon (Web browser -> Multicon controller)
8080	TCP	Web socket traffic from UI to Multicon (Web browser -> Multicon controller)
2836	TCP + UDP	Primary port for Spread distribution mechanism (Multicon -> Multicon)
2837	TCP + UDP	Aux port for Spread (Multicon -> Multicon)
2838	TCP + UDP	Aux port for Spread (Multicon -> Multicon)
3972	TCP + UDP	NeviON Configurator to device communication (NeviON Configurator -> Multicon, Control Panel, Sublime routers)
4381	TCP	MRP connections (Control Panel -> Multicon) (Multicon -> Sublime routers)

In addition, any ports used by third party protocol must be open.

7 Web Interface

Multicon includes a common web interface for Flashlink and VikinX monitoring and control. Common features are described in this chapter while the Flashlink specific features are described the chapter Flashlink web interface.

7.1 General

There are five common views in the Multicon Web interface. Each has its own menu tab at the top, and will be highlighted when selected.

- Frames (Optional, for monitoring and configuration of Flashlink cards or Sublime X2)
- Config (Multicon configuration settings, e.g. user access, SNMP, firmware upgrade etc)
- Alarms (All alarms within the system)
- Log (Shows last 4000 events after power up)
- Manuals (All user manuals in PDF-format)

In addition, there are optional views for web control. These are described in the Web Control Interface chapter.

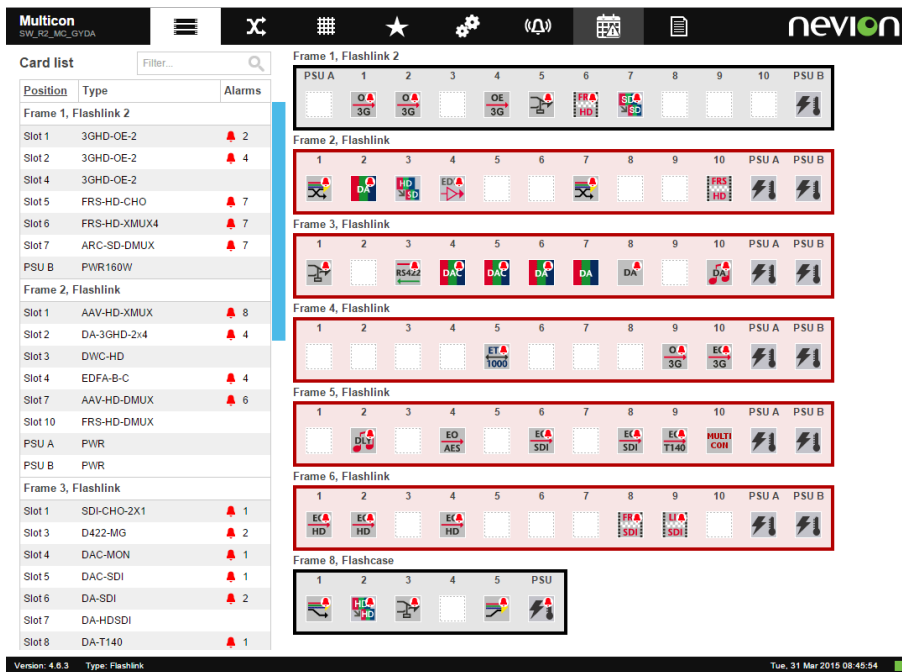

Figure 7.1 Multicon web interface menu bar

7.2 Alarms Page

All active alarms in the system are shown under the ALARMS tab with information about time, alarm source, severity, description and user for each alarm. It is also possible to acknowledge an alarm from this page and filter alarms based on text input.

The alarm status column takes the following values:

- NEW (red color) means new active alarm not yet acknowledged.
- ACKNOWLEDGED (yellow color) means active alarm that have been acknowledged.
- RESTORED (green color) means cleared alarm (no longer active) and not yet acknowledged.

Note that restored alarms that are acknowledged will be removed from this list, i.e. alarms will not be removed from the list until they have been acknowledged. Complete alarm history can be found in the log.

Time	Source	Severity	Description	User	State	Acknowledge
2015-Mar-25 08:25:09	MULTICON_GYDA, Flashlink, Frame 1, Slot 02 (Address 1)	Warning	ETH100: Optical input	guest	New	Acknowledge
2015-Mar-31 08:28:04	MULTICON_GYDA, Flashlink, Frame 1, Slot 10 (Address 9)	Warning	HD-OE-2: Optical input 1	guest	Acknowledged	Acknowledge
2015-Mar-25 08:25:09	MULTICON_GYDA, Flashlink, Frame 1, Slot 10 (Address 9)	Warning	HD-OE-2: Optical input 2	guest	New	Acknowledge
2015-Mar-25 08:25:09	MULTICON_GYDA, Flashlink, Frame 2, Slot 01 (Address 10)	Warning	DA-VAEQ-6: Electrical input	guest	New	Acknowledge
2015-Mar-25 08:25:09	MULTICON_GYDA, Flashlink, Frame 3, Slot 10 (Address 29)	Warning	LB-OE: Optical input	guest	New	Acknowledge
2015-Mar-25 08:25:09	MULTICON_GYDA, Flashlink, Frame 3, Slot 10 (Address 29)	Warning	LB-OE: 15V (LNB)	guest	New	Acknowledge
2015-Mar-25 08:25:09	MULTICON_GYDA, Flashlink, Frame 4, Slot 03 (Address 32)	Warning	10G-TR: Optical input	guest	New	Acknowledge
2015-Mar-25 08:25:09	MULTICON_GYDA, Flashlink, Frame 4, Slot 03 (Address 32)	Warning	10G-TR: Reclocker	guest	New	Acknowledge
2015-Mar-31 08:28:26	MULTICON_GYDA, Flashlink, Frame 4, Slot 05 (Address 34)	Warning	ETH-GbE-SW-10G: 10/100/1000 port 1	guest	Acknowledged	Acknowledge
2015-Mar-31 08:28:27	MULTICON_GYDA, Flashlink, Frame 4, Slot 05 (Address 34)	Warning	ETH-GbE-SW-10G: 10/100/1000 port 2	guest	Acknowledged	Acknowledge
2015-Mar-31 08:28:27	MULTICON_GYDA, Flashlink, Frame 4, Slot 05 (Address 34)	Warning	ETH-GbE-SW-10G: 10/100/1000 port 3	guest	Acknowledged	Acknowledge
2015-Mar-25 08:25:09	MULTICON_GYDA, Flashlink, Frame 4, Slot 05 (Address 34)	Warning	ETH-GbE-SW-10G: 10/100/1000 port 4	guest	New	Acknowledge
2015-Mar-25 08:25:09	MULTICON_GYDA, Flashlink, Frame 4, Slot 05 (Address 34)	Warning	ETH-GbE-SW-10G: 10/100/1000 port 5	guest	New	Acknowledge
2015-Mar-25 08:25:09	MULTICON_GYDA, Flashlink, Frame 4, Slot 05 (Address 34)	Warning	ETH-GbE-SW-10G: 10GbE port	guest	New	Acknowledge
2015-Mar-25 08:25:09	MULTICON_GYDA, Flashlink, Frame 4, Slot 05 (Address 34)	Warning	ETH-GbE-SW-10G: Optical input	guest	New	Acknowledge
2015-Mar-25 08:25:09	MULTICON_GYDA, Flashlink, Frame 4, Slot 09 (Address 38)	Warning	ETH1000-SFP: Ethernet	guest	New	Acknowledge
2015-Mar-25 08:25:09	MULTICON_GYDA, Flashlink, Frame 4, Slot 09 (Address 38)	Warning	ETH1000-SFP: Optical input	guest	New	Acknowledge
2015-Mar-25 08:25:09	MULTICON_GYDA, Flashlink, Frame 5, Slot 06 (Address 45)	Warning	AES-VMUX: AES10	guest	New	Acknowledge
2015-Mar-31 08:26:49	MULTICON_GYDA, Flashlink, Frame 7, Slot 08 (Address 67)	Warning	HD-TD-10GMX-6: Input integrity 1 (HD/SD)	guest	Restored	Acknowledge
2015-Mar-31 08:25:28	MULTICON_GYDA, Flashlink, Frame 7, Slot 08 (Address 67)	Warning	HD-TD-10GMX-6: Input integrity 2 (HD/SD)	guest	Restored	Acknowledge
2015-Mar-31 08:28:02	MULTICON_GYDA, Flashlink, Frame 7, Slot 08 (Address 67)	Warning	HD-TD-10GMX-6: Input integrity 3 (HD/SD)	guest	Restored	Acknowledge
2015-Mar-31 08:26:49	MULTICON_GYDA, Flashlink, Frame 7, Slot 08 (Address 67)	Warning	HD-TD-10GMX-6: Input integrity 4 (HD/SD)	guest	Restored	Acknowledge
2015-Mar-31 08:26:49	MULTICON_GYDA, Flashlink, Frame 7, Slot 08 (Address 67)	Warning	HD-TD-10GMX-6: Input integrity 5 (HD/SD)	guest	Restored	Acknowledge

Figure 7.2 Multicon web interface alarms page

The alarm page shows alarms from any device in a Multicon system, for example a Flashlink card, VikinX Sublime/Modular routers or 3rd party interfaces. Each device has it's own alarms, please refer to the user manual for details about a specific device.

Multicon has also some general system alarms:

- Health alarms
 - High CPU load
 - Almost out of memory
- Communication alarms

- Lost communication to a subsystem (Flashlink cards, Sublime/Modular routers)
- Lost communication to other Multicons in the system

Alarm severities that are used:

- Critical - Will affect operation and control, take action immediately
- Major - Major problem, but will not affect operation and control immediately
- Minor - Minor problem, should be investigated
- Warning - Warning about change in a module, should be investigated
- Info - Used only for information



Note: Alarms from Flashlink cards does not support severity and are set to “Warning” as default.

7.3 Log Page

The log page shows log entries for the entire Multicon system, i.e. all Multicon controllers will update other controllers with the latest log entries. The Web interface shows the latest 4000 log entries since last restart of the controller.

The following information is displayed per log entry:

- Time – Timestamp when the log entry was first recorded
- Source – The Multicon controller that initiated the log entry, N/A if user initiated like crosspoint setting from control panel.
- Severity – May be either “Info” for information entries (normal event) or “Warning” for warning entries (problem event).
- Text – Textual description of the log entry.
- User – The user that performed the action that initiated the log entry, N/A if action was initiated by Multicon controller.

The log may also be retrieved in CSV format either using HTTP or FTP from the Multicon controller. The log in CSV format contains the same information that is available from the Web interface.

HTTP URL for retrieval of CSV formatted log: <http://<MulticonIPAddress>/conf/logs/mc>

How-to retrieve CSV formatted log via FTP:

```
ftp <MulticonIPAddress>
cd /cf/logs
get mc
quit
```

Time	Source	Severity	Description	User
2013-Aug-23 11:03:55	SW_R3_MC_GYDA - 3GHD-EO-2	Info	Position 8, rack 3: Activated alarm: Reclocker 2	
2013-Aug-23 11:03:49	SW_R3_MC_GYDA - 3GHD-EO-2	Info	Position 8, rack 3: Restored alarm: Reclocker 2	
2013-Aug-23 10:53:27	SW_R3_MC_GYDA - 3GHD-EO-2	Info	Position 8, rack 3: Activated alarm: Reclocker 2	
2013-Aug-23 10:53:24	SW_R3_MC_GYDA - 3GHD-EO-2	Info	Position 8, rack 3: Restored alarm: Reclocker 2	
2013-Aug-23 10:35:14	SW_R3_MC_GYDA - 3GHD-EO-2	Info	Position 8, rack 3: Activated alarm: Reclocker 2	
2013-Aug-23 10:35:09	SW_R3_MC_GYDA - 3GHD-EO-2	Info	Position 8, rack 3: Restored alarm: Reclocker 2	
2013-Aug-23 10:04:10	SW_R3_MC_GYDA	Info	Position 3, rack 7: Restored alarm: Card removed	
2013-Aug-23 10:04:10	SW_R3_MC_GYDA - pos 3, rack 7	Info	Ending hot-swap configuration	
2013-Aug-23 10:04:10	SW_R3_MC_GYDA - pos 3, rack 7	Info	Starting hot-swap configuration	
2013-Aug-23 10:04:07	SW_R3_MC_GYDA - pos 3, rack 7	Info	New SDI-TD-MUX-4-T card in pos 3 in rack 7	
2013-Aug-23 10:03:55	SW_R3_MC_GYDA - pos 3, rack 7	Info	SDI-TD-MUX-4-T card removed	
2013-Aug-23 10:03:55	SW_R3_MC_GYDA	Info	Position 3, rack 7: Activated alarm: Card removed	
2013-Aug-23 05:59:10	SW_R3_MC_GYDA	Info	Position 3, rack 7: Restored alarm: Card removed	
2013-Aug-23 05:59:09	SW_R3_MC_GYDA - pos 3, rack 7	Info	Ending hot-swap configuration	
2013-Aug-23 05:59:09	SW_R3_MC_GYDA - pos 3, rack 7	Info	Starting hot-swap configuration	
2013-Aug-23 05:59:07	SW_R3_MC_GYDA - pos 3, rack 7	Info	New SDI-TD-MUX-4-T card in pos 3 in rack 7	
2013-Aug-23 05:59:04	SW_R3_MC_GYDA - pos 3, rack 7	Info	SDI-TD-MUX-4-T card removed	
2013-Aug-23 05:58:58	SW_R3_MC_GYDA	Info	Position 3, rack 7: Activated alarm: Card removed	
2013-Aug-22 23:48:32	SW_R3_MC_GYDA - DA-HDSDI	Info	Position 7, rack 2: Activated alarm: Clock recovery	
2013-Aug-22 23:48:29	SW_R3_MC_GYDA - DA-HDSDI	Info	Position 7, rack 2: Restored alarm: Clock recovery	

Figure 7.3 Multicon web interface log page

Example of CSV formatted log:

```
ip:N/A|hostname:N/A|item:0|itemname:N/A|user:guest|severity:Info|type:Event|text:Level 102, output 1 to input 1|time:2010-Jan-04 15:41:39.588358
ip:N/A|hostname:N/A|item:0|itemname:N/A|user:guest|severity:Info|type:Event|text:Level 102, output 2 to input 3|time:2010-Jan-04 15:41:39.588750
ip:N/A|hostname:N/A|item:1|itemname:N/A|user:N/A|severity:Info|type:Event|text:ParamGroup 1, parameter 3 to unknown|time:2010-Jan-05 08:09:27.022952
ip:192.168.110.50|hostname:Demo_MC_GYDA|item:-1|itemname:N/A|user:N/A|severity:Info|type:Event|text:New FRS-HD-CHO card in pos 6 in rack 1|time:2010-Jan-05 08:09:32.545409
```

7.4 Config Page

7.4.1 User and Access Setup

Note: When Multicon is running as part of a Multicon system, no changes to user and passwords are allowed through the web interface. In this case, use the tools provided by NeviON Configurator.

To enable password protection for the webinterface go to the Settings tab and select “Flashlink”. It is only possible to enable password protection from this page. All other user and access configuration must be performed using the NeviON Configurator.

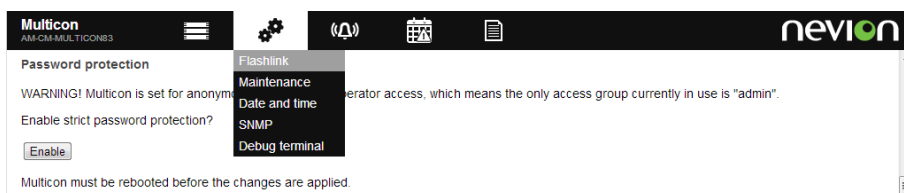

Figure 7.4 Multicon enable password protection

When password protection is enabled, all users have to login with a username and password. This will also prevent SNMP v1 and v2c access to the Multicon controller and only allow SNMP v3 access.



Note: When strict password is enabled, a separate browser has to be used to access the webpage. Nevion Configurator internal webpage viewer does not support strict password.

Per default Multicon allows anonymous access (no user authentication) to all pages except for the Settings tab which requires administrator rights.



Note: Factory settings include the following users (username/password):

- admin/password with administrator rights (assigned to admin group)
- guest/password with read-only rights (assigned to guest group)
Remember to change the passwords to prevent abuse of the Multicon system.

You can manage users and groups using the Nevion Configurator by selecting “Current system” and “User management” from the menu. This will show an overview of existing users and groups. To add new groups click “New” to open the following dialog. Enter information as requested and select appropriate GYDA Web page – operational level from the drop down.

The different levels are further explained below.

The screenshot shows a 'General' dialog box for adding a new group. It contains the following fields and options:

- Name: MyGroup
- Alias: (empty field)
- Description: (empty field)
- Users in this group have the following rights:
 - Control Panels - Access level: 0
 - System Configurator - Configuration level: Guest
 - GYDA Web page - operational level: Eng
 - SNMP Control - control level: Eng

Figure 7.5 Configurator
add new group

When password protection is enabled the following Web interface access rights may be assigned to user groups using the Nevion Configurator:

- None – No access to the Web interface
- Guest – Read-only access, can't acknowledge alarms or re-configure modules.
- Oper – Operator access has access to acknowledging alarms and re-configuring modules.
- Eng – Engineering access with full access rights excluding Settings tab
- Admin – Full rights including the Settings tab

To add new users click “New” to open the following dialog. Enter information as requested and select the appropriate group with the desired access rights for this user.

Member of user groups:	
Name ▲	Access level
<input type="checkbox"/> admin	255
<input type="checkbox"/> guest	0
<input checked="" type="checkbox"/> MyGroup	0

Figure 7.6 Configurator add new user

7.4.2 Date and Time

The date and time page allows you to set the local time zone for the controller. Note that the controller always operates in UTC time internally. The local time zone is only used for the Web interface.

You have the option of specifying the current date and time manually from the Web interface. The time should be relative to the time zone set above.

Alternatively it is also possible to specify a NTP server for automatic setting of time. Note that since DNS is not in use on the controller you have to specify a static IP address for the NTP server.

Notes when specifying date and time manually from Web interface:

- Multicon Mk2 has a battery and will remember the current date and time values when powered down. Upon startup it will read these values and display correct date and time.
- Multicon Mk4 does not have a battery. If date and time are manually set, then current date and time values will be lost when powered down. Multicon will then display date and time starting from January 1st 1970 after startup. To avoid this, configure a NTP server.

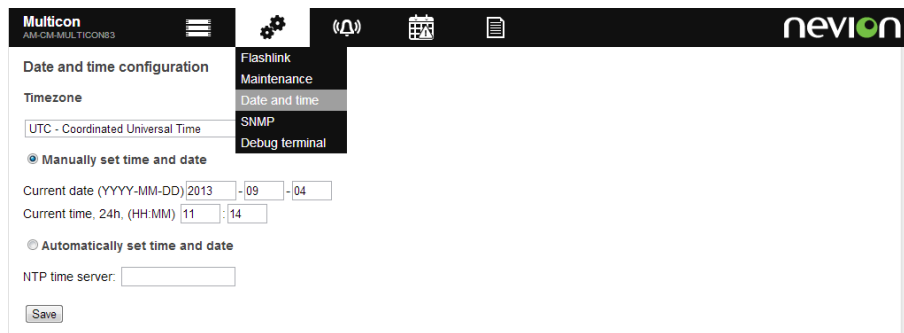

Figure 7.7 Multicon web date and time setup

7.4.3 Flashlink

This tab is for Flashlink use only and described in [Section 8.4](#).

7.4.4 Debug Terminal

Debug terminal is for Flashlink use only and described in [Section 8.5](#).

7.4.5 SNMP Setup

Multicon includes an SNMP agent. This means that all the Flashlink modules, VikinX Sublime and VikinX Modular can be accessed from a higher level third-party management system. The SNMP MIB information is described in a separate manual, Multicon SNMP Data Model.

For Flashlink full monitoring and configuration of all modules is supported. For VikinX Sublime configuration of router crosspoints is supported. For VikinX Modular full monitoring and configuration is supported.

Setup is done through the web interface. This is found under the Settings tab and SNMP settings.

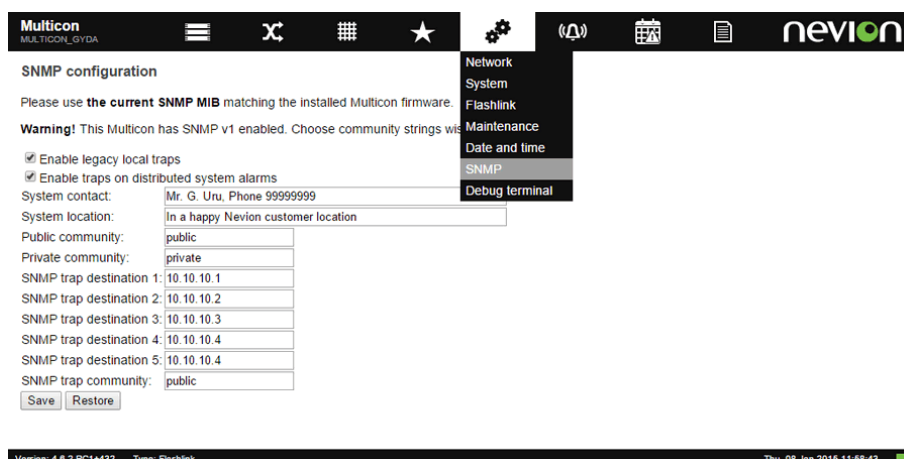

Figure 7.8 Multicon web SNMP settings

There are two global settings for traps:

Enable legacy local traps

Enables all Flashlink traps from locally controlled Flashlink cards.

Enable traps on distributed system alarms

Enables all system alarms, common for every Multicon in the system, which includes all alarms from Flashlink, VikinX, 3rd party control and internal status.

Additional Flashlink trap configuration:

- If both of the trap settings are enabled, Multicon will send out two traps for every alarm
- To disable legacy traps from a card, use the "Ignore"-option on SNMP Trap configuration
- To disable system traps from a card, use the "Ignore"-option on Alarm configuration

The following SNMP settings are available:

- sysContact: contact person and contact details for the service person.
- sysLocation: where is the system located.
- SNMP public community: password to access the SNMP agent
- SNMP private community: password to access the SNMP agent
- SNMP trap destination 1-5: IP-address of the SNMP manager (up to five different destinations are supported)
- SNMP trap community: password to access the SNMP manager



Note: Community strings are only used for SNMP v1 and v2c. SNMP v3 access requires login using a Multicon administrator user.

If password protection is enabled, the User-based Security Model from SNMP v3 is used instead of community strings. In this case an administrator user is required for SNMP login as described in [Section 7.4.1](#) apply for SNMP.

System traps are defined with a general structure and contains four fields:

- alarmNum (integer)– Internal alarm id
- alarmSeverty (integer) – Alarm severity (1-Info, 2-Warning, 3-Minor, 4-Major, 5-Critical)
- alarmOrigin (string) – Consists of device hostname, module type and module info (for example card and slot numbers)
- alarmDescription (string) – Consists of module name and alarm text

7.4.6 Maintenance

From the Settings tab under Maintenance, information about the system is shown including the IP address and MAC address of the Multicon. **Figure 7.9** gives an example of the information provided.

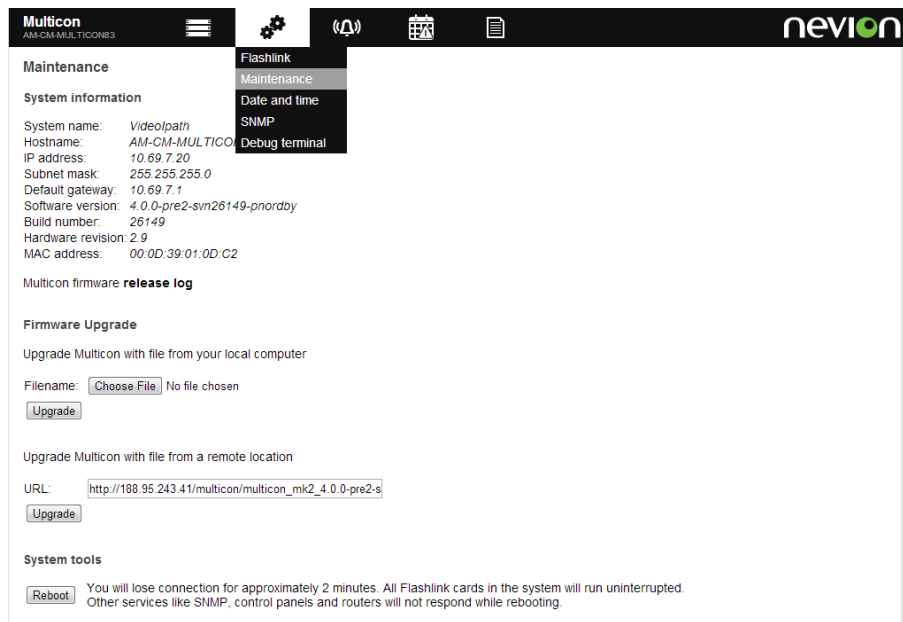

Figure 7.9 Multicon web maintenance page

Software upgrade of the Multicon controller may also be performed from this page. Please refer **Chapter 11** for further information about the upgrade procedure.

Software upgrade may also be performed from the NeviON Configurator tool. This also allows upgrade of multiple controllers simultaneously.

It is also possible to restart the controller from the maintenance page. After reboot it may take up to two minutes before the controller is accessible again.

7.5 Manuals

The manuals page shows all manuals stored on the CF-card of the Multicon controller. You can easily access the manuals by clicking on the View link.

It is possible to update the manuals page either by removing the CF-card and extracting a new manual archive file into the /manuals directory on the CF-card. Alternatively all the files of the manual archive file may be transferred using FTP into the /cf/manuals directory.

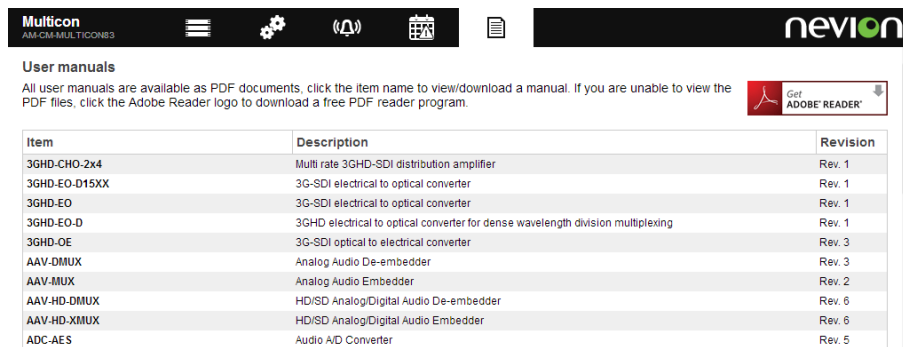

Item	Description	Revision
3GHD-CHO-2x4	Multi rate 3GHD-SDI distribution amplifier	Rev. 1
3GHD-EO-D15XX	3G-SDI electrical to optical converter	Rev. 1
3GHD-EO	3G-SDI electrical to optical converter	Rev. 1
3GHD-EO-D	3GHD electrical to optical converter for dense wavelength division multiplexing	Rev. 1
3GHD-OE	3G-SDI optical to electrical converter	Rev. 3
AAV-DMUX	Analog Audio De-embedder	Rev. 3
AAV-MMUX	Analog Audio Embedder	Rev. 2
AAV-HD-DMUX	HD/SD Analog/Digital Audio De-embedder	Rev. 6
AAV-HD-XMUX	HD/SD Analog/Digital Audio Embedder	Rev. 6
ADC-AES	Audio A/D Converter	Rev. 5

Figure 7.10 Multicon web manuals page

8 Flashlink Web Interface

The Flashlink tab gives you an overview of your entire Flashlink system where you can drill-down to each individual card, view current status information, and make configuration changes as required.



Note: If Multicon web page is loaded during startup of the Multicon controller, the card list may be empty. Please issue a hard refresh of the page using Ctrl-F5 in your browser to show the Flashlink tab in this case.

8.1 Flashlink Sub-system View

Multicon can control and monitor up to 80 modules, in a total of 8 frames (note that there is also a license that is limited to 10 modules). This is illustrated in the figure below. You access this page by clicking on the Flashlink tab from the top-level menu.

The module label will also be displayed when hovering over a module icon in this view.

A configurable label per frame is shown on the right hand side. This can be modified under the Settings tab and General Setup.

Calculated power supply utilization is shown on the PSU. This is based on 60W power supplies operating redundantly. The main purpose of this function is to make sure that the power supplies are not overloaded.

8.2 Flashlink Module View

You enter the Flashlink module view either by selecting a frame from the left hand frame list or selecting a module directly from the Flashlink sub-system overview. This is illustrated in [Figure 8.2](#).

To the left we see the detection and indication of the 1-8 frames that are connected to the system. In this case frame 6 is selected of the 8 frames that are connected to Multicon. On the frame itself, we see the indication of the active card as a grey frame on the red front. By clicking the different positions or icons of the frame, the different card modules can be controlled.

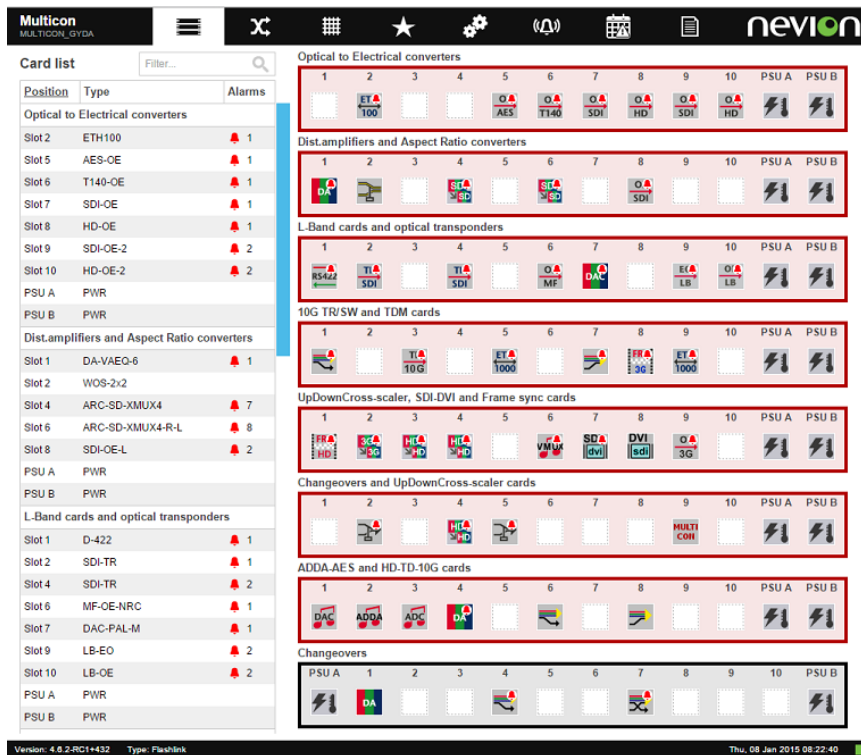

Figure 8.1 Flashlink Card view

Each of the different modules in the modular Flashlink range has a dedicated icon, which will appear in the corresponding position of the frame.

In this view the current module that is view is highlighted while the other modules in the same frame are dimmed.

The GYDA Web interface has three different pages for each module as seen at the bottom of the page.



8.2.1 Information Page

Figure 8.3 shows the contents of the module information page for the Flashlink AV-HD-XMUX module. It consists of a module block diagram that is dynamically updated based on signals received by the module and configuration of the module. For instance if the embedder matrix is reconfigured then the picture will be updated accordingly.

The page also includes status parameters as reported by the module and the current alarms active on this module. The information on the module information page is updated every second.

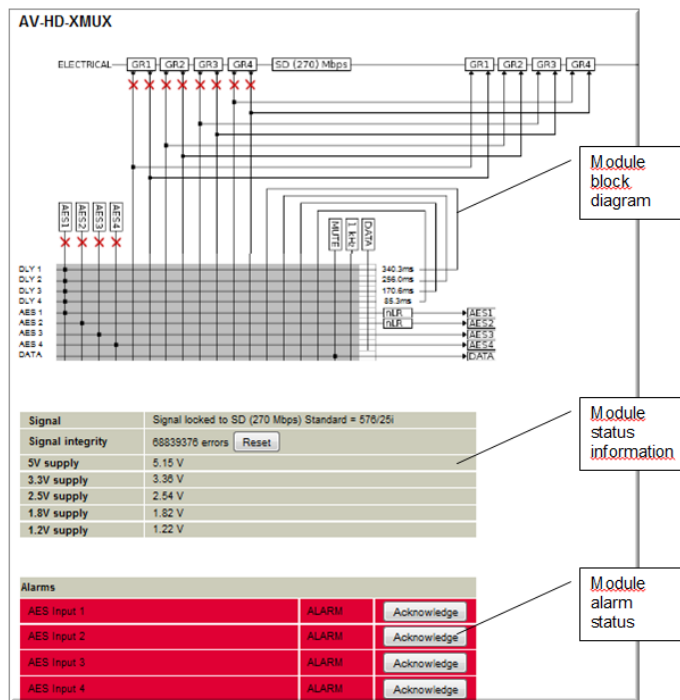

Figure 8.3 Flashlink information page

8.2.2.2 Advanced Configuration

The user interface includes a feature to hide advanced configuration options. This is due to the large number of available configuration options available especially on the signal processing and distribution range of Flashlink modules.

The figure below shows Video In options without advanced configuration which is the default display. To show advanced configuration options click on the arrow to the right.



The figure below shows Video In options with advanced configuration options.



8.2.2.3 Matrix Configuration

The figure below shows an example matrix configuration. The inputs are shown horizontally on the X-axis and outputs are shown vertically on the Y-axis. Matrix configuration will be reflected in the block diagram on the module information page.

The screenshot shows the Flashlink configuration page with a top navigation bar containing 10 numbered slots and PSU A/PSU B. Below this is a configuration table with the following settings:

- Phase delay: 0 lines, 0 samples
- Video frame delay: 1 frames, -2 lines, 0 samples
- Relative Audio demb. del: 0 samples
- AES input 1 delay: 0 samples
- AES input 2 delay: 0 samples
- AES input 3 delay: 0 samples
- AES input 4 delay: 0 samples
- Video in: Mode: Auto, Main: Electrical
- Video generator: Video format: 576/25i, Pattern: Black, Flat: Y:0, Cb:0, Cr:0
- Label generator: Enable, Disable, Auto
- Video processing: Legalizer: On, Off
- EDH generator: Active, Inactive
- Signal integrity: Max error rate: 10 errors/s, Max error count: 250 errors, Alarm hold time: 60 s

Below the main settings is the SDI out section with input options (Through, Processed) and output 1/2 selection. The Audio matrix section is a grid for routing AES inputs to video groups.

	AES input				Group 1		Group 2		Group 3		Group 4		1 kHz	Mute
	1	2	3	4	1-2	3-4	5-6	7-8	9-10	11-12	13-14	15-16		
Group 1 ch1-2:	<input type="radio"/>	<input type="radio"/>	<input type="radio"/>	<input type="radio"/>	<input checked="" type="radio"/>	<input type="radio"/>	<input type="radio"/>	<input type="radio"/>	<input type="radio"/>	<input type="radio"/>	<input type="radio"/>	<input type="radio"/>	<input type="radio"/>	<input type="radio"/>
Group 1 ch3-4:	<input checked="" type="radio"/>	<input type="radio"/>	<input type="radio"/>	<input type="radio"/>	<input type="radio"/>	<input type="radio"/>	<input type="radio"/>	<input type="radio"/>	<input type="radio"/>	<input type="radio"/>	<input type="radio"/>	<input type="radio"/>	<input type="radio"/>	<input type="radio"/>
Group 2 ch5-6:	<input type="radio"/>	<input checked="" type="radio"/>	<input type="radio"/>	<input type="radio"/>	<input type="radio"/>	<input type="radio"/>	<input type="radio"/>	<input type="radio"/>	<input type="radio"/>	<input type="radio"/>	<input type="radio"/>	<input type="radio"/>	<input type="radio"/>	<input type="radio"/>
Group 2 ch7-8:	<input checked="" type="radio"/>	<input type="radio"/>	<input type="radio"/>	<input type="radio"/>	<input type="radio"/>	<input type="radio"/>	<input type="radio"/>	<input type="radio"/>	<input type="radio"/>	<input type="radio"/>	<input type="radio"/>	<input type="radio"/>	<input type="radio"/>	<input type="radio"/>
Group 3 ch9-10:	<input type="radio"/>	<input type="radio"/>	<input type="radio"/>	<input type="radio"/>	<input type="radio"/>	<input type="radio"/>	<input checked="" type="radio"/>	<input type="radio"/>	<input type="radio"/>	<input type="radio"/>	<input type="radio"/>	<input type="radio"/>	<input type="radio"/>	<input type="radio"/>
Group 3 ch11-12:	<input type="radio"/>	<input type="radio"/>	<input type="radio"/>	<input type="radio"/>	<input type="radio"/>	<input type="radio"/>	<input type="radio"/>	<input checked="" type="radio"/>	<input type="radio"/>	<input type="radio"/>	<input type="radio"/>	<input type="radio"/>	<input type="radio"/>	<input type="radio"/>
Group 4 ch13-14:	<input type="radio"/>	<input type="radio"/>	<input type="radio"/>	<input type="radio"/>	<input type="radio"/>	<input type="radio"/>	<input type="radio"/>	<input type="radio"/>	<input checked="" type="radio"/>	<input type="radio"/>	<input type="radio"/>	<input type="radio"/>	<input type="radio"/>	<input type="radio"/>
Group 4 ch15-16:	<input type="radio"/>	<input type="radio"/>	<input type="radio"/>	<input type="radio"/>	<input type="radio"/>	<input type="radio"/>	<input type="radio"/>	<input type="radio"/>	<input type="radio"/>	<input checked="" type="radio"/>	<input type="radio"/>	<input type="radio"/>	<input type="radio"/>	<input type="radio"/>

Figure 8.4 Flashlink configuration page

Audio matrix	Group 1		Group 2		Group 3		Group 4		Generator	
	1-2	3-4	5-6	7-8	9-10	11-12	13-14	15-16	1 kHz	Black
Emb ch 1-2:	<input checked="" type="radio"/>	<input type="radio"/>	<input type="radio"/>	<input type="radio"/>	<input type="radio"/>	<input type="radio"/>	<input type="radio"/>	<input type="radio"/>	<input type="radio"/>	<input type="radio"/>
Emb ch 3-4:	<input type="radio"/>	<input checked="" type="radio"/>	<input type="radio"/>	<input type="radio"/>	<input type="radio"/>	<input type="radio"/>	<input type="radio"/>	<input type="radio"/>	<input type="radio"/>	<input type="radio"/>
Emb ch 5-6:	<input type="radio"/>	<input type="radio"/>	<input checked="" type="radio"/>	<input type="radio"/>	<input type="radio"/>	<input type="radio"/>	<input type="radio"/>	<input type="radio"/>	<input type="radio"/>	<input type="radio"/>
Emb ch 7-8:	<input type="radio"/>	<input type="radio"/>	<input type="radio"/>	<input checked="" type="radio"/>	<input type="radio"/>	<input type="radio"/>	<input type="radio"/>	<input type="radio"/>	<input type="radio"/>	<input type="radio"/>
Emb ch 9-10:	<input type="radio"/>	<input type="radio"/>	<input type="radio"/>	<input type="radio"/>	<input checked="" type="radio"/>	<input type="radio"/>	<input type="radio"/>	<input type="radio"/>	<input type="radio"/>	<input type="radio"/>
Emb ch 11-12:	<input type="radio"/>	<input type="radio"/>	<input type="radio"/>	<input type="radio"/>	<input type="radio"/>	<input checked="" type="radio"/>	<input type="radio"/>	<input type="radio"/>	<input type="radio"/>	<input type="radio"/>
Emb ch 13-14:	<input type="radio"/>	<input type="radio"/>	<input type="radio"/>	<input type="radio"/>	<input type="radio"/>	<input type="radio"/>	<input checked="" type="radio"/>	<input type="radio"/>	<input type="radio"/>	<input type="radio"/>
Emb ch 15-16:	<input type="radio"/>	<input type="radio"/>	<input type="radio"/>	<input type="radio"/>	<input type="radio"/>	<input type="radio"/>	<input type="radio"/>	<input checked="" type="radio"/>	<input type="radio"/>	<input type="radio"/>

8.2.2.4 Alarm Configuration

Alarm configuration is available for all Flashlink modules, and the module configuration page will include a list of all available alarms for the module. The figure below shows an example with four alarms.

Alarm	Upper limit	Lower limit	Alarm	SNMP trap
Electrical input			<input checked="" type="radio"/> Normal <input type="radio"/> Ignore	<input type="radio"/> Send <input checked="" type="radio"/> Ignore
Optical input			<input checked="" type="radio"/> Normal <input type="radio"/> Ignore	<input type="radio"/> Send <input checked="" type="radio"/> Ignore
5.0V	5500	4500	<input checked="" type="radio"/> Normal <input type="radio"/> Ignore	<input type="radio"/> Send <input checked="" type="radio"/> Ignore
3.3V	3600	3000	<input checked="" type="radio"/> Normal <input type="radio"/> Ignore	<input type="radio"/> Send <input checked="" type="radio"/> Ignore

The following configuration is possible:

- Alarm may be set to Normal or Ignore. Normal means that the alarm will be displayed on the Multicon ALARM tab and on the module information page. Ignore means that the alarm will not be displayed.
- SNMP trap may be set to Send or Ignore. Send means that the alarm will be sent as a SNMP trap to the SNMP Manager defined on the Multicon settings tab. Ignore means that no SNMP trap will be sent.
- Upper limit defines an upper threshold value for numeric parameters monitored by Multicon. If the parameter is higher than this upper limit an alarm will be generated.
- Lower limit defines a lower threshold value for numeric parameters monitored by Multicon. If the parameter is lower than this lower limit an alarm will be generated.

8.2.2.5 Passive Modules

Passive optical modules like: WDM, CWDM, DWM and WOC don't contain any microcontroller which makes them able to communicate with Multicon. However, through Multicon it is possible to assign a graphical icon and a label for the module to make it visible in the Multicon user interface. The procedure is as follows:

1. Click on the slot where the passive optical device is installed.
2. Press the "Tool" button below the frame.
3. Select the type of module from the "Card type" pull down menu.
4. If needed give the module a name in the "Card label" box.
5. Press Apply.

The graphical icon and the name of the module will appear when returning to the SYSTEM tab, as shown in figure below.

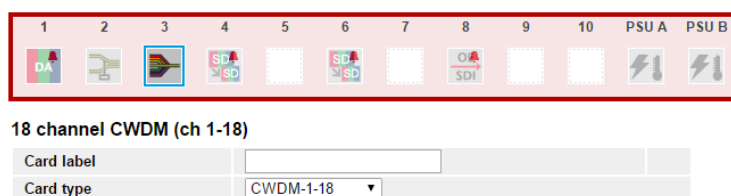

8.3 Multicon Module View

Figure 8.5 shows the module view for the Multicon module, which in this case is placed in frame 7 and slot 10.

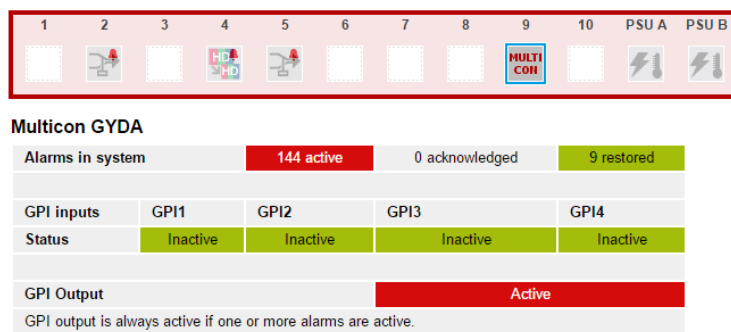

Figure 8.5 Multicon module view

The Multicon module information page gives you a summary of the alarms in the system. Each alarm can be in one of three different states:

- Active (red color). An alarm is present in the system, and is not acknowledged.
- Acknowledged (yellow color). A present alarm that has been acknowledged.

The alarm will disappear from the list as soon as the condition that set the alarm no longer exists.

- Restored (green color). The condition that set the alarm does no longer exist. The alarm must be acknowledged in order to disappear from the list.

The status for the GPI inputs of the Multicon element manager is shown below the alarm list. The status can be either active (triggered by an external device) or inactive.

The GPI output can also be in one of two states. The GPI output is an open collector for all GPI input. If one or more alarms are active in the system, the GPI output will be active, whereas if all alarms are either acknowledged, restored or there are no alarms in the system, it will be inactive.

For more information about connecting the GPI inputs refer to [Section 12.11](#).

Multicon module view will also show information about Ethernet interfaces. It is possible to configure which speeds and duplex modes the interface will advertise when autonegotiating. This is done by setting two configuration options; "Speed" and "Duplex". [Table 8.1](#) shows what will be advertised when the different settings are selected.



Warning: Make sure at least one of the advertised settings is supported by the equipment on the other end of the cable. If not, no link will be established and the Flashlink web interface might be unreachable.



Note: 1000baseT/Full is only available on Multicon hardware revision 4.

The Ethernet switch (see [Figure 12.15](#)) bandwidth is limited to 400 Mbits/sec. To make sure this limitation isn't exceeded, it is good practice to configure the interfaces to only advertise 100 Mbits/sec. This is the default setting for Multicon with SFP.

Table 8.1 Advertised by autonegotiation.

Configuration		Advertised by autonegotiation				
Speed	Duplex	10baseT/Half	10baseT/Full	100baseT/Half	100baseT/Full	1000baseT/Full
Auto	Auto	Yes	Yes	Yes	Yes	Yes
10 Mbits/sec	Auto	Yes	Yes	No	No	No
100 Mbits/sec	Auto	No	No	Yes	Yes	No
1000 Mbits/sec	Auto	No	No	No	No	Yes
Auto	Half	Yes	No	Yes	No	No
10 Mbits/sec	Half	Yes	No	No	No	No
100 Mbits/sec	Half	No	No	Yes	No	No
1000 Mbits/sec	Half	Not allowed, will be changed to 1000baseT/Full				
Auto	Full	No	Yes	No	Yes	Yes
10 Mbits/sec	Full	No	Yes	No	No	No
100 Mbits/sec	Full	No	No	No	Yes	No
1000 Mbits/sec	Full	No	No	No	No	Yes

For Multicon modules with SFP, status and configuration for the SFP is available on Multicon module view.



Warning: It is possible to disable the SFP output. If the optical Ethernet interface was used when connecting the PC to the Flashlink web interface, disabling the SFP output will make it unreachable.

8.4 Flashlink Maintenance

General Flashlink configuration options are found under the settings tab and Flashlink. This includes ability to configure power supplies, frame labels and create and restore system configurations.

8.4.1 Frame configuration

This includes options to configure 60 or 75W power supplies for each frame and whether one or two power supplies are present. This information is used to calculate power utilization on the Flashlink main overview page. The detection method is used to determine frame version 1 or 2.

- Auto (default) - Detect both frame version 1 and 2
- Legacy - Detect only frame version 1
- Off - Do not detect frames with this address

Flashlink setup

Frame configuration

Power type is common for both PSU's and not applicable for the high power frame.
 Detection method can be limited to legacy or disabled for each frame.
 Reboot is required for the changes to take effect.

	Power type	Installed powers	Detection method
Frame 1:	<input type="radio"/> 60W <input checked="" type="radio"/> 75W	<input type="radio"/> PSU A <input type="radio"/> PSU B <input checked="" type="radio"/> PSU A + PSU B	<input type="radio"/> Off <input type="radio"/> Legacy <input checked="" type="radio"/> Auto
Frame 2:	<input type="radio"/> 60W <input checked="" type="radio"/> 75W	<input type="radio"/> PSU A <input type="radio"/> PSU B <input checked="" type="radio"/> PSU A + PSU B	<input type="radio"/> Off <input type="radio"/> Legacy <input checked="" type="radio"/> Auto
Frame 3:	<input type="radio"/> 60W <input checked="" type="radio"/> 75W	<input type="radio"/> PSU A <input type="radio"/> PSU B <input checked="" type="radio"/> PSU A + PSU B	<input type="radio"/> Off <input type="radio"/> Legacy <input checked="" type="radio"/> Auto
Frame 4:	<input type="radio"/> 60W <input checked="" type="radio"/> 75W	<input type="radio"/> PSU A <input type="radio"/> PSU B <input checked="" type="radio"/> PSU A + PSU B	<input type="radio"/> Off <input type="radio"/> Legacy <input checked="" type="radio"/> Auto
Frame 5:	<input type="radio"/> 60W <input checked="" type="radio"/> 75W	<input type="radio"/> PSU A <input type="radio"/> PSU B <input checked="" type="radio"/> PSU A + PSU B	<input type="radio"/> Off <input type="radio"/> Legacy <input checked="" type="radio"/> Auto
Frame 6:	<input type="radio"/> 60W <input checked="" type="radio"/> 75W	<input type="radio"/> PSU A <input type="radio"/> PSU B <input checked="" type="radio"/> PSU A + PSU B	<input type="radio"/> Off <input type="radio"/> Legacy <input checked="" type="radio"/> Auto
Frame 7:	<input type="radio"/> 60W <input checked="" type="radio"/> 75W	<input type="radio"/> PSU A <input type="radio"/> PSU B <input checked="" type="radio"/> PSU A + PSU B	<input type="radio"/> Off <input type="radio"/> Legacy <input checked="" type="radio"/> Auto
Frame 8:	<input type="radio"/> 60W <input checked="" type="radio"/> 75W	<input type="radio"/> PSU A <input type="radio"/> PSU B <input checked="" type="radio"/> PSU A + PSU B	<input type="radio"/> Off <input type="radio"/> Legacy <input checked="" type="radio"/> Auto

Frame labels

Set label on Flashlink frames.
 Reboot is required for the changes to take effect.

Frame 1:	<input type="text" value="F0"/>
Frame 2:	<input type="text" value="F1"/>
Frame 3:	<input type="text" value="F2"/>
Frame 4:	<input type="text" value="F3"/>

Figure 8.6 Flashlink general configuration

8.4.2 Frame Labels

A label may defined for each frame in the Flashlink system. These will be shown on the Flashlink main overview page.

8.4.3 Card Configurations

To create a stored system configuration simply type in a name for the system configuration and click Save. A previously saved configuration may be restored by selecting this configuration and clicking on Load.

System configurations

Save configuration parameters on all Flashlink cards in one file.
 Loading a saved configuration will interrupt all Flashlink cards in the system.

<input type="text"/>	<input type="button" value="Save"/>
<input type="text"/>	<input type="button" value="Load"/>
<input type="text"/>	<input type="button" value="Delete"/>

Figure 8.7 Flashlink stored configurations

Configuration names should not contain any special characters or whitespace. The configuration files are stored under the configs directory on the CF card, in a directory with the same name as the stored setup.

For setup of multiple cards with identical or similar setups, this mechanism can be used to simplify the process. Files with a sav suffix are the actual configuration, while lab suffix files are the card labels. The number before the suffix is the card position number, where 00 is card 1 in rack 0, and 79 is card 10 in rack 7.

The hot swap configuration restore mechanism is also the basis of the stored configuration reload function. After copying the stored configuration files back to their original location, all cards are released in order to run the hot swap configuration restore function when they are rediscovered.

Control and monitoring will be lost for a brief period ranging from a few seconds to a few minutes, depending on how many cards are controlled by the system.

8.4.3.1 Transfer System Configurations

This procedure is written to explain how card configuration may be transferred from one Flashlink module to another module of the same type. Note both cards should have the same firmware revision.

Transfer between modules in the same Flashlink system:

1. Goto “Settings -> Flashlink -> Stored system configurations” menu in the web interface
2. Create new stored configuration by entering name and clicking “Save”
3. Telnet to the Multicon controller, default login is “root” and “password” and enter the following commands:

```
cd /cf/configs/<stored_configuration_name>  
cp <source_card_no>.sav <dest_card_no>.sav
```

1. where <source_card_no> and <dest_card_no> is $10 * \text{FrameNumber} + \text{SlotNumber} - 1$ (e.g. $10 * 1 + 5 - 1 = 14$ for frame 1 and slot 5)
2. Repeat the above step for multiple cards if necessary
3. Goto “Settings -> Flashlink -> Stored system configurations” menu in GYDA-SC web interface
4. Load stored configuration by clicking on name and “Load”

This procedure may be automated using a script if necessary and this is recommended if used extensively.

It is also possible to transfer configurations between different Flashlink sub-systems, but in this case they.sav files above needs to be FTPed between the Multicon controllers handling the two Flashlink sub-systems.

8.5 Debug Terminal

The debug terminal allows you to issue Flashlink Protocol commands directly towards the modules in the Flashlink sub-system. This is only useful for debugging purposes and is generally only used when instructed by NeviON Support. The commands accepted by different Flashlink modules are described in the user manual for respective module.

The Debug Terminal is accessed from the Settings tab -> Debug terminal. [Figure 8.8](#) shows the output of the info command for a example card.

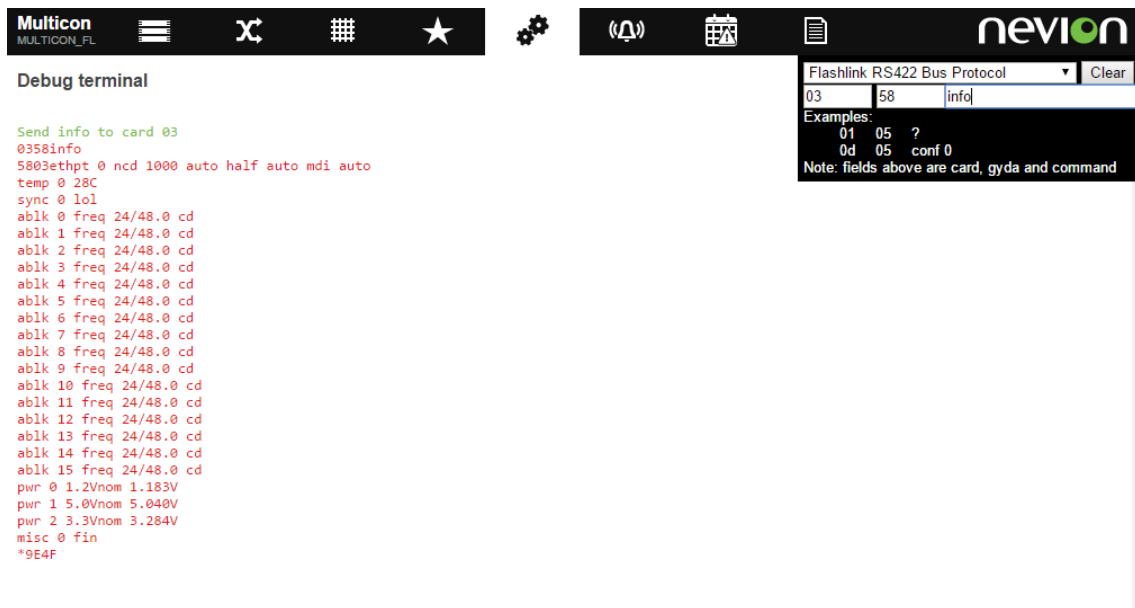

Figure 8.8 Flashlink debug terminal

The card number is constructed of <frame_number> and <slot_number> - 1, in this case the module is in frame 1 and slot 2. Click OK to execute the command.

8.6 Flashlink Firmware Upgrade

Newer Flashlink cards may be firmware upgraded from the Multicon web interface. Please contact support if firmware upgrade of older Flashlink cards is required. Currently the following Flashlink cards are supported:

- ARC-SD-DMUX
- D-422-MG
- DA3G-HD
- DWC-HD-DMUX
- FRS-HD-CHO
- FRS-HD-DMUX
- AAV-HD-DMUX
- AAV-HD-XMUX
- AAV-SD-DMUX
- AAV-SD-XMUX
- All new Flashlink cards released in 2010 and later

The firmware upgrade process is described in detail below. Note that some modules require only micro-controller upgrade while modules with FPGA may also require a FPGA upgrade.



Note: Take caution to ensure that there are no power failures during the firmware upgrade process or the module is removed from the housing as this may render the module unusable.

8.6.1 Transfer Firmware Files to Multicon

Copy firmware files to Multicon is done on the webinterface in the Maintenance section. Click on the “Choose File” button to select file and click “Upload” to upload the file. Unused files can also be deleted by clicking the “Delete” button.

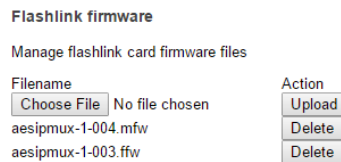

Figure 8.9 Upload Flashlink firmware

8.6.2 Micro Controller Upgrade Process

First select card from Flashlink tab in the Multicon web interface, then go to the configuration page. At the bottom you will find the current firmware versions. In the example below the micro-controller version is 1.04 and the FPGA version is 1.27. Note down the current versions before commencing with the upgrade process.

Card version	
FW	1.27
SW	1.04

At the top of the configuration page you will find a firmware upgrade dropdown list with the files you have copied to the Multicon controller. Select the ??? .mfw file to upgrade the micro-controller and then click OK at the bottom of the screen.

FRS-HD-CHO

Card label	<input type="text"/>	Locate Card	<input type="text"/>	sec
Firmware upgrade	Upload file:	frshdcho-0-109.mfw		
Phase delay	-5	samples		
Video delay	0	lines	0	samples

Wait for the upload to complete. When the micro-controller is upgraded the top LED will light yellow and the other LEDs will be dark.

FLOADER

State:	Flash not programmed
Application:	Writing file to flash, 22185 of 105080 bytes

When the upload is finished you will be asked to boot the card, click the “Boot card” button below.

FLOADER

State:	Flash programmed
Reset to test:	<input type="button" value="Boot card"/>
Application:	Waiting for reset

The card will boot and the following status will be shown on the information page.

Firmware upgrade	Programming mode
------------------	------------------

Now the micro-controller firmware upgrade have to be finalized, to do this you go to the configuration page and click the “Finalize” button below.

FRS-HD-CHO

Card label	<input type="text"/>	<input type="button" value="Locate Card"/>	<input type="text" value=""/>	sec
Firmware upgrade	Programming mode	<input type="button" value="Finalize"/>		
Firmware upgrade	Upload file:	None		

Finally go to the bottom of the configuration page and check that the firmware version has changed. In this case, the micro-controller version (denoted as SW below) has changed from 1.04 to 1.09.

Card version	
FW	1.27
SW	1.09

8.6.3 FPGA Upgrade Process

First select card from Flashlink tab in the Multicon web interface, then go to the configuration page. At the bottom you will find the current firmware versions. In the example below the FPGA version is currently 1.27.

At the top of the configuration page you will find a firmware upgrade dropdown list with the files you have copied to the Multicon controller. Select the ????.ffw file to upgrade the FPGA firmware and then click OK at the bottom of the screen.

FRS-HD-CHO

Card label	<input type="text"/>	<input type="button" value="Locate Card"/>	<input type="text" value=""/>	sec
Firmware upgrade	Upload file:	None		
Phase delay	-5	None	<input type="text" value=""/>	samples
Video delay	2	frshdcho-0-109.mfw	<input type="text" value=""/>	lines
		frshdcho-0-155.ffw	<input type="text" value="0"/>	samples

Wait for the upload to complete and reaches 100% as depicted below.

Dloader	Programming	FPGA 92.78 %
---------	-------------	--------------

When the upload is complete programming of the FPGA will commence and the following status will be shown. At this point the LEDs on the card will blink yellow.

Dloader	Busy	
---------	------	--

When programming is complete the information page will be displayed. Go to the configuration page to check that the new firmware version is loaded. In this case, the FPGA is upgraded from version 1.27 to 1.55.

Card version	
FW	1.55
SW	1.09

9 Web Control Interface

Multicon 4.0 introduces a new Web Control feature (Multicon OPT-WC) that may be used to control routers and matrixes in Flashlink from the Web interface.

When enabled the Web Control feature adds three new views to the Multicon web page:

- List View to control routers from a list of sources and destinations
- Matrix View to control routers from a matrix with sources and destinations
- Salvo View to execute salvos that are available in the Multicon system



Note: Web Control feature is not restricted to traditional router control and may also be used to control Flashlink matrixes (e.g. embedder/dembedder) and to execute salvos with Flashlink parameters.

9.1 List View

Figure 9.1 shows the new List View with available inputs and outputs from the selected routing level. The List View also supports virtual routing tables in addition to physical levels.

Inputs				Outputs					
#	Name	Description	Presence	#	Name	Description	Input	Presence	Lock state
1	My IN001		Missing	1	OUT001		My IN001	Missing	Unlock
2	IN002		Missing	2	OUT002		My IN001	Missing	Unlock
3	IN003		Missing	3	OUT003		IN022	Missing	Lock
4	IN004		Missing	4	OUT004		IN021	Missing	Lock
5	IN005		Missing	5	OUT005		IN018	Missing	Lock
6	IN006		Missing	6	OUT006		IN016	Missing	Lock
7	IN007		Missing	7	OUT007		IN022	Missing	Unlock
8	IN008		Missing	8	OUT008		IN008	Missing	Unlock
9	IN009		Missing	9	OUT009		IN025	Missing	Protect
10	IN010		Missing	10	OUT010		IN006	Missing	Protect
11	IN011		Missing	11	OUT011		IN026	Missing	Unlock
12	IN012		Missing	12	OUT012		IN008	Missing	Unlock
13	IN013		Missing	13	OUT013		IN019	Missing	Unlock
14	IN014		Missing	14	OUT014		IN005	Missing	Unlock
15	IN015		Missing	15	OUT015		IN018	Missing	Unlock
16	IN016		Missing	16	OUT016		IN010	Missing	Unlock
17	IN017		Missing	17	OUT017		IN024	Missing	Unlock
18	IN018		Missing	18	OUT018		IN015	Missing	Unlock
19	IN019		Missing	19	OUT019		IN008	Missing	Unlock
20	IN020		Missing	20	OUT020		IN019	Missing	Unlock
21	IN021		Missing	21	OUT021		IN026	Missing	Unlock
22	IN022		Missing	22	OUT022		IN022	Missing	Unlock

Figure 9.1 Web control list view

The following information is shown for an input:

- Configured name (label) for the input.
- Configured description for the input.

- Signal presence status for the input (present missing or unknown).

The following information is shown for an output:

- Configured name (label) for the input.
- Configured description for the input.
- Signal presence status for the input (present missing or unknown).
- Input port that has been routed to the output.
- Lock state for the output (lock, protect or unlock).

The following functions are available from the List View:

- Select input and output(s) and click Take to set the crosspoint.
- Select output(s) and click Lock or Protect to lock or protect an output to a specific input.
- Select output(s) that have previously been locked or protected and click Unlock to remove the lock or protect.



Note: Several outputs may be selected for all of the above functions by clicking the Multiselect button.

The List View also supports direct editing of names and descriptions for inputs and outputs. To enable the editing mode click the Edit button and perform required changes. When all changes are done unclick the Edit button.



Note: The edit functionality is also available for systems that have been configured using the NeviON Configurator.

Figure 9.2 shows how to select a routing level to display and control in the List View. Simply hover the mouse of the List View icon to show the available levels and click on one to select it.

#	Name	Description	Input	Presence	Lock state
1	My IN001		My IN001	Missing	Unlock
2	IN002		My IN001	Missing	Unlock
3	IN003		IN022	Missing	Unlock
4	IN004		IN021	Missing	Unlock
5	IN005		IN018	Missing	Unlock
6	IN006		IN016	Missing	Unlock
7	IN007		IN022	Missing	Unlock
8	IN008		IN008	Missing	Unlock
9	IN009		IN025	Missing	Unlock
10	IN010		IN022	Missing	Unlock

Figure 9.2 Web control list view selection

9.2 Matrix View

Figure 9.3 shows the new Matrix View with available inputs and outputs for the selected routing level. The Matrix View only supports physical levels. Virtual routers is not supported.

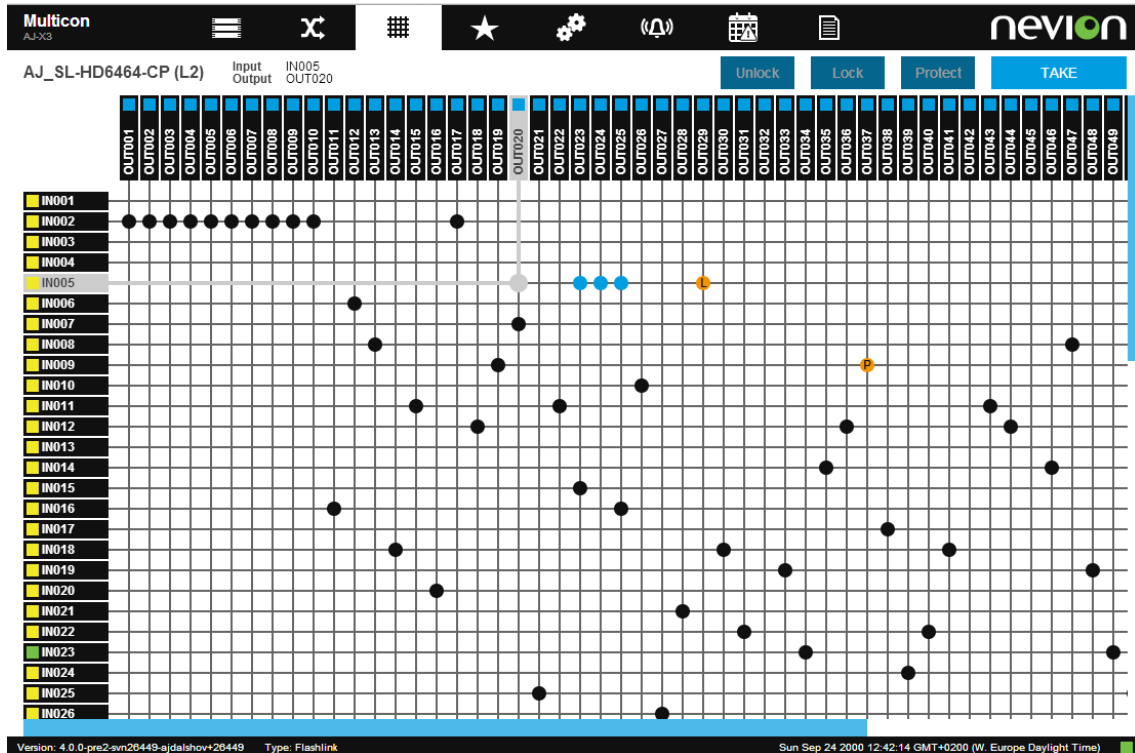

Figure 9.3 Web control matrix view

The following information is shown for inputs and outputs:

- Configured name (label) for the input or output.
- Signal presence is presented using a colored symbol next to the name (green means signal present, yellow signal missing and blue unknown).

Inputs are presented vertically on the left side of the matrix and outputs are presented horizontally on the top.

The operator may position the mouse pointer over a crosspoint connecting an input and output and select this to be set. Note several crosspoint settings may be made at once. The Take button is clicked to set the selected crosspoints for the selected level.

The operator can also select an already set crosspoint in order to lock or protect it. Only one crosspoint may be selected at a time for the lock and protect functions. To activate the lock or protect click the Lock or Protect buttons at the top right of the view.

Unlocking works in a similar manner by selecting a crosspoint that has previously been locked or protected and click the Unlock button.



Note: The maximum recommended size for matrixes is 64x64. Although larger levels is possible, but are not practical to manage in this view as scrolling will typically be necessary.

9.3 Salvo View

Figure 9.4 shows the new Salvo View for executing salvos available in the system.

#	Name	Description	State	Lock state
1	Setup 1	This is setup 1	Inactive	Unlock
2	Setup 2	This is setup 2	Active	Unlock
3	Setup 3	This is setup 3	Inactive	Unlock
4	Setup 4	This is setup 4	Inactive	Unlock
5	Setup 5	This is setup 5	Inactive	Unlock
6	Desk 1	This is desk 1	Inactive	Unlock
7	Desk 2	This is desk 2	Active	Unlock
8	Desk 3	This is desk 3	Inactive	Unlock
9	Desk 4	This is desk 4	Inactive	Unlock
10	Desk 5	This is desk 5	Inactive	Unlock

Figure 9.4 Web control salvo view

Salvos are organized into salvo groups in a Multicon system. When hovering the mouse pointer over the salvo icon, a list of available salvo groups is presented. After selecting the right salvo group, a list of the salvos in this group is presented.

The following information is shown for a salvo:

- Configured name (label) for the salvo.
- Configured description for the salvo.
- Activation status for the salvo (inactive or active). A salvo is active if all settings in the salvo matches the current state of the included routers or devices.
- Lock state for the salvo (lock, protect or unlock).

To activate a salvo first select the salvo and click Take. Lock and protect of a salvo is performed by selecting the salvo and then clicking the Lock or Protect buttons. Unlock is performed in a similar way.



Note: Lock or protect of salvo affects all settings included in the salvo.



Note: Salvos may only be configured from the Nevion configurator.

10 System Overview

This feature is discontinued as of Multicon 3.7.0. To use this feature software version 3.6.4 or older must be used. Please consult manual revision H for more information about using this feature.

11 Software Upgrade



Note: Note this chapter is only applicable for products based on hardware revision 2.

11.1 Introduction

11.1.1 GYDA-SC Upgrade

Multicon GYDA automatically detect all modules that are part of the Flashlink sub-system (consisting of up to 8 frames). As the product range is expanded with additional modules, a new release of the Multicon GYDA software is made in order to detect and monitor the new modules.

All new modules in the Flashlink range released after 2010-01-01 will require the new Multicon GYDA element manager for Web/SNMP monitoring and control capabilities. For modules released prior to this date the previous GYDA-SC product may still be used.

To support new modules for existing installations with GYDA-SC, an upgrade of GYDA-SC to Multicon GYDA is required for the Flashlink systems where the new modules are installed. Two different hardware revisions exist for the GYDA-SC module:

- All GYDA-SC HW revision 2 modules may be software upgraded to Multicon GYDA.
- All GYDA-SC HW revision 1 modules must be exchanged with a new Multicon GYDA module.

To identify which hardware version that you have you may check the CONFIG tab in the GYDA-SC user interface. See figure below.



Figure 11.1 GYDA-SC hardware version



Note: Note that GYDA-SC and Multicon GYDA can co-exist in a network, but it is necessary to upgrade if new Flashlink cards shall be used in a sub-system.

11.1.2 ETH-CON and SYSCON Upgrade

The main reason to upgrade from ETH-CON and Syscon to Multicon is to take advantage of the new functionality offered by Multicon. It is also highly recommended to run the same system controller for the entire installation as this simplifies both operation and maintenance.

It should also be noted that the new Sublime SL-3GHD128128 comes with an embedded Multicon controller which means that if you are using this router in your system then other system controllers should also be running Multicon.

11.2 Upgrade from GYDA-SC, ETH-CON and SYSCON to Multicon

The upgrade procedure from GYDA-SC to Multicon GYDA is described in detail in the Multicon Upgrade Guide.



Note: Note that it is required to use the Upgrader tool that is shipped with the Nevision Configurator for this upgrade as it guides you through the process.



Note: Note that upgrade from ETH-CON, Syscon and GYDA-SC to Multicon requires appropriate license keys to be installed. Contact Nevision sales or your local distributor for further information.

11.3 Upgrade Procedure for Multicon

This chapter describes the upgrade procedure for Multicon systems and is independent of the license keys that you have installed. The upgrade procedure is the same for Multicon GYDA, Multicon VX-SLC and Multicon VX-MOD.

Download the software from Nevision Europe or use one provided for you by our support department. The latest software versions on the Multicon product page at <http://www.nevision.com>.



Note: Take caution to ensure that there are no power failures during the firmware upgrade process or the card is removed from the housing as this may render the card unusable.

11.3.1 Using Nevision Configurator

Nevision Configurator can be used to upgrade firmware, allowing multiple controllers to be upgraded simultaneously. This allows for the most efficient upgrade of all controllers in the system. The upgrade procedure is described in detail below:

1. Open the Nevision Configurator.
2. Select a system to open or click cancel. Note that it is not necessary to open a system to perform an upgrade.

3. Go to Tools -> Firmware upgrade from the menu bar.
4. Select the device (or devices) to upgrade as shown in the figure below.

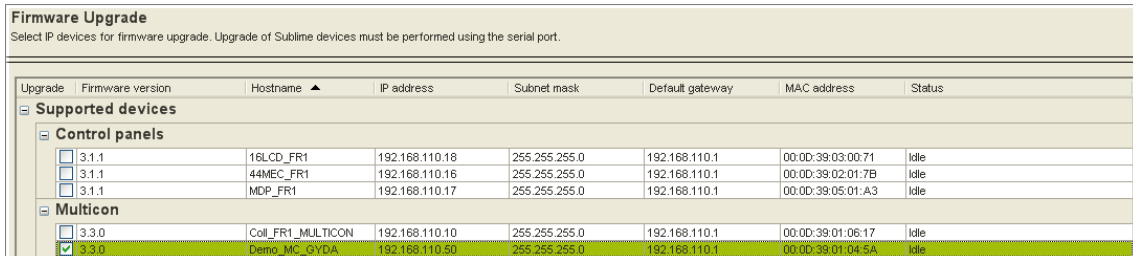

1. Click on Upgrade at the bottom of the window.
2. Select the upgrade file from the dialog shown below. Note that the latest firmware is always shipped with the NeviON Configurator, but you can also choose a file you have downloaded into another directory.

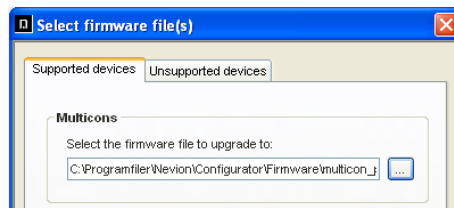

1. Click OK
2. The upgrade file is uploaded to a Multicon controller and the progress is shown in the NeviON Configurator. Note that the file may not necessarily be uploaded to the controller you are upgrading.



1. Optionally the upgrade file is downloaded from another controller to the controller that shall be upgraded.

1. The upgrade procedure starts and the progress is shown in the NeviON Configurator.



1. The upgrade procedure finishes and you are requested to reboot. Alternatively if any errors occurred during the upgrade the error message will be displayed. In this case, try to run the upgrade again. If the problem persists please contact NeviON Support.

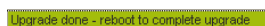

1. Make sure that the device to be upgraded is still selected and click Reboot at the bottom of the window to complete the upgrade.

11.3.2 Using Multicon Web Interface

It is possible to upgrade using the Multicon Web interface.

1. Access the Settings tab, subsection “Firmware upgrade”.
2. Select the firmware upgrade file by pressing “Choose” or “Browse” (depending on your web browser), then press “Upgrade”.

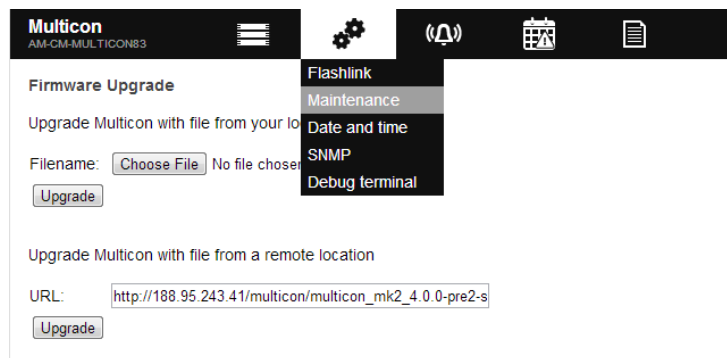

Figure 11.2 Multicon web upgrade

1. The upgrade process will then upload and install the firmware upgrade, this will take a few minutes.
2. Multicon must be restarted after the process is completed.

12 Hardware Information

12.1 Housing

It is possible to place the Multicon controller either in a Flashlink frame or in an N-BOX housing as illustrated as shown below.

Normally the Multicon controller is placed in a Flashlink frame to control up to 8 frames. The Multicon controller may be placed in any frame and slot of the Flashlink sub-system, but it is recommended to place the controller in frame 0 slot 10.

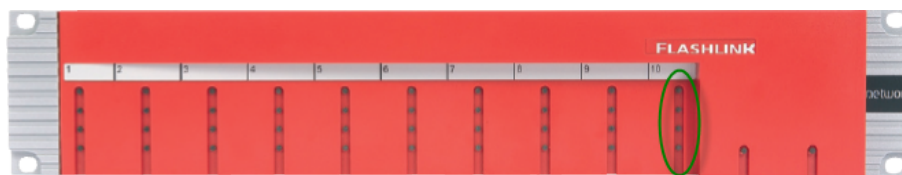

Figure 12.1 Multicon in Flashlink frame with LEDs

In special circumstances it is also possible to place Multicon in a N-BOX housing for controlling up to 3 other Flashlink cards in separate N-BOX housings. Note that this requires a special cable for inter-connecting the modules.



Figure 12.2 Multicon in N-BOX with LEDs

Normally the Multicon controller is placed in a N-BOX housing to control VikinX Sublime, but if multiple controllers are in use, the Multicon controller may also be placed in a Flashlink housing for this purpose. One benefit of this is that the Flashlink frame can be fitted with redundant power supplies.

Note that only one controller in the Flashlink frame may have licenses to control the Flashlink sub-system to prevent collisions on the Flashlink internal communication bus. This is not a problem if all the controllers in the frame are Multicon VX-SLC products.

The Multicon VX-MOD controller has to be placed inside the VikinX Modular frames. The frame allows two redundant controllers to be inserted as depicted in the figure below. If only one controller is in use it is recommended to place this in the left-most position.

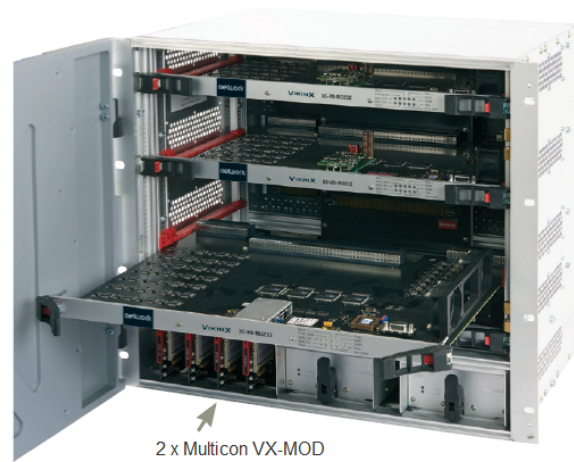

Figure 12.3 Multicon in VikinX Modular

12.2 Status LEDs

There are 4 LEDs on the front side of Multicon of the controller card.



Figure 12.4 LEDs on Multicon hardware revision 2

Table 12.1 LED status on Multicon hardware revision 2

LED/State	Red LED	Yellow LED	Green LED	No light
STATUS	Card error	n.a.	Overall status of the card is OK	Card has no power, or is not inserted correctly
ETH	n.a.	10 Mb/s link	100 Mb/s link	No Ethernet link (check cable)
WARN	Abnormal situation, requires attention.	Booting/firmware upgrade in progress	Normal situation	n.a.
LOAD	n.a.	Controller busy	Controller Idle	n.a.

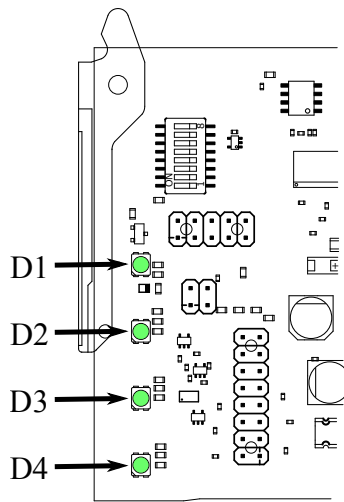

Figure 12.5 LEDs on Multicon hardware revision 4

Table 12.2 LED status on Multicon hardware revision 4

LED/State	Red LED	Yellow LED	Green LED	No light
D1	Card error	n.a.	Overall status of the card is OK	Card has no power, or is not inserted correctly
D2	n.a.	10/100 Mb/s link	1000 Mb/s link	No Ethernet link (check cable)
D3	n.a.	10/100 Mb/s link	1000 Mb/s link	No Ethernet link (check cable)
D4 ¹	n.a.	Controller busy	Controller Idle	n.a.
D4 ²	n.a.	n.a.	1000 Mb/s link	No Ethernet link (check cable)

¹ Used when DIP 7 is off, see [Table 12.4](#).

² Used when DIP 7 is on, see [Table 12.4](#).

Table 12.3 Special LED statuses on Multicon hardware revision 4

D1	D2	D3	D4	Description
Red	Off	Off	Off	Card error.
Off	Off	Off	Off	Unable to start bootloader. MicroSD card is missing or does not have the software installed.
Yellow	Yellow	Yellow	Yellow	Same as above.
Yellow	Off	Off	Off	Bootloader is running.
Off	Yellow	Off	Off	Operating system is booting.
Off	Off	Off	Yellow	Operating system is halted.
Blink yellow	Blink yellow	Blink yellow	Blink yellow	“Locate Card” is activated. See Multicon user manual for details.

12.3 How to Access the Module

How to access the module depends on the housing as described below:

- For the Flashlink frame, remove the front cover and access the module from the front of the frame.
- For the N-BOX housing, the module is accessible through the front of the box. If service or inspection is required, open the unit from the front.
- For the VikinX Modular frame, open the front door and access the module(s) in the bottom left corner of the frame.

Please refer to the manuals for the respective housings for further details.

12.4 Card Insertion and Removal

The box is equipped with guide rails to align the controller card into its position. Slide the card into the guide rails inside the box until the card enters the backplane with a slight “click”. The card is locked and proper contact ensured with the blue handle in its downright position.



Note: Do not use excessive force; the card should enter easily – proper insertion is almost effortless.

To remove a module card, release the card by moving the blue handle until it is in horizontal position, and then pull the card out of the box with the blue handle.

12.5 Storage

All the information regarding the Multicon configuration, as well as information regarding control panels that are connected to Multicon, is stored on the controller card. Hardware revision 2 uses CF card, Hardware revision 4 uses MicroSD card.

12.5.1 CF card (Mk2 only)

If it is necessary to remove and/or insert a CF card, the following must be done:

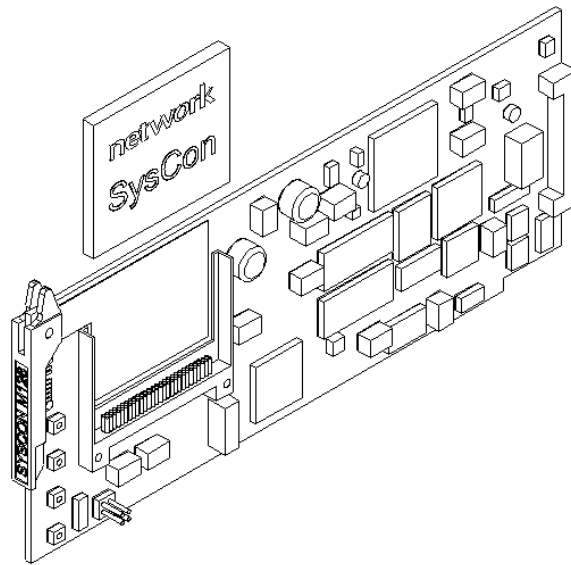

Figure 12.6 CF card on the controller card

1. Remove the controller card from its slot, according to the description earlier in this manual.
2. Slide the CF card out of its socket, and insert the new CF card into the socket.
3. Insert the controller card into its slot, according to the description earlier in this manual.

12.5.2 MicroSD card (Mk4 only)

If it is necessary to remove and/or insert a MicroSD card, the following must be done:

1. Remove the controller card from its slot, according to the description earlier in this manual.
2. Push the MicroSD card to release from its socket, and insert the new MicroSD card into the socket. Push it to make it stay.
3. Insert the controller card into its slot, according to the description earlier in this manual.

12.6 Battery (Mk2 only)

If it is necessary to remove and/or insert a battery, the following must be done:

1. Remove the controller card from its slot, according to the description earlier in this manual.
2. Slide the battery out of its socket, and insert the new battery into the socket.
3. Insert the controller card into its slot, according to the description earlier in this manual.

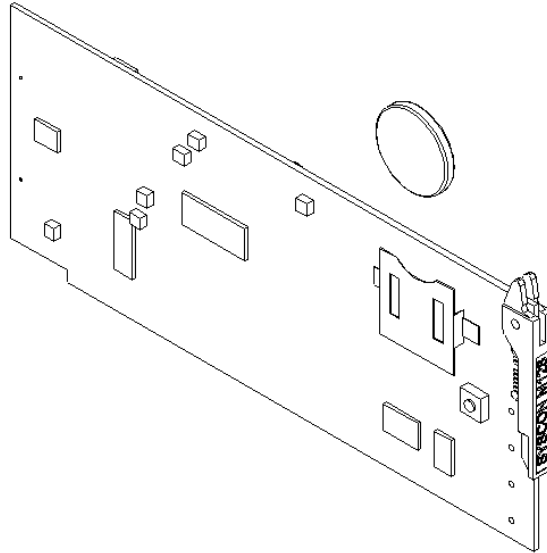

Figure 12.7 Battery on the controller card

12.7 Reset Button (Mk2 only)

The reset button on the rear side is used to perform a hard reset of the card. Do not perform a hard reset, unless the situation demands this. By performing a hard reset, the user loses control of the Multicon, and will not get control of Multicon until approximately 20 seconds after releasing the reset button.

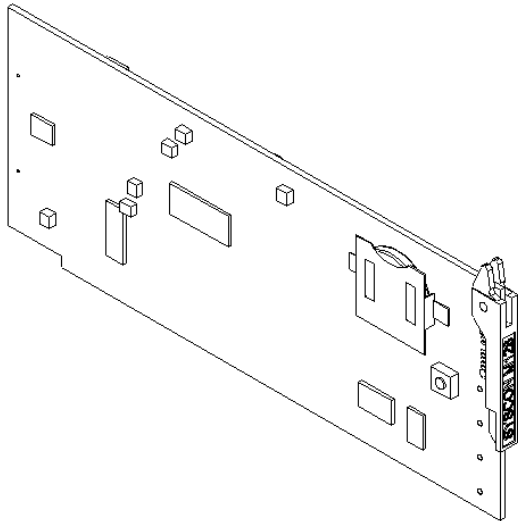

Figure 12.8 Reset button on the controller card

12.8 DIP switches (Mk4 only)

The DIP switches are only available on Multicon hardware revision 4. They are located on the upper left corner of the board, see [Figure 12.9](#). [Table 12.4](#) shows how they are used.

Factory default settings for the DIP switches are all **off** for Multicon without SFP. This is also the case for Multicon with SFP except DIP 8 which will be **on** when shipped from factory.

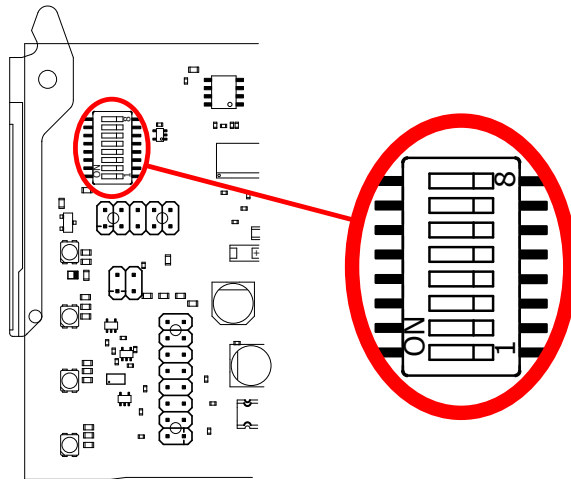

Figure 12.9 Location of DIP switches

Table 12.4 Dip switches on Multicon hardware revision 4

DIP	Off	On	Notes
DIP 8	Optical gigabit Ethernet SFP will not be used.	Enable optical gigabit Ethernet SFP. Alarms will be activated if communication with the SFP fails.	On Multicon with SFP, this should always be on. On Multicon without SFP, this should always be off.
DIP 7	Use LED D4 to show controller load.	Use LED D4 to show optical gigabit Ethernet link status.	Only used if DIP 8 is on. If DIP 8 is off, LED D4 will show controller load.
DIP 6	n.a	n.a.	
DIP 5	n.a	n.a.	
DIP 4	n.a	n.a.	
DIP 3	n.a	Reset user configuration to factory default.	See Section 12.8.1 .
DIP 2	n.a	Reset Multicon software to factory image.	See Section 12.8.1 .
DIP 1	n.a	n.a.	

12.8.1 Factory default procedure

Factory image contains the Multicon software at the time the Multicon was produced. If the current software on Multicon is not working as expected, the factory image can be activated. This image can be used to upgrade Multicon to a working software version.

Reset configuration to factory default functionality can be used, if your configuration (levels, virtual routers, salvos, button configurations, serial ports etc.) has been corrupted, or you want to start from scratch.

Follow this procedure to enable factory default image and/or reset configuration

1. Eject Multicon card from the frame or N-Box
2. Set DIP switch 2 and/or 3 on, depending on your needs
3. Reinsert card and observe LED status
4. When the three first LEDs are off and the fourth (at bottom) LEDs is yellow, eject Multicon card again
5. Set DIP switches back to default
6. Reinsert card

Use either NeviON Configurator or webpages to start configuring the Multicon again.

12.9 Flashlink Card Hot Swap

All Flashlink cards are designed to be hot swappable. No special commands or sequencing is necessary to perform the swap, just extract the card to be replaced from the Flashlink frame and insert the new card.



Note: All setup is restored to the state of card last seen in the same position, if and only if the new card is of the same type and the previous card was extracted after the last controller reset. In all other situations, the internal card state is considered correct and not touched.

12.10 Back Plane Connectors

12.10.1 Hardware revision 2

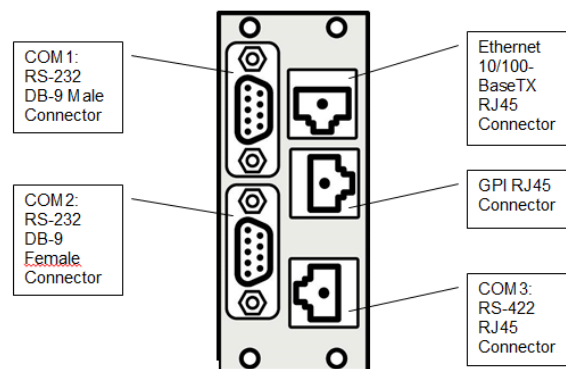

Figure 12.10 Back plane for controller card

The following service connectors can be found on the rear of the Multicon hardware revision 2:

COM1 - DB9 Male

Use this to connect either VikinX routers or third party equipment, using RS-232 or RS-422 control protocols.

COM2 - DB9 Female

Use this to connect either VikinX routers or third party equipment, using RS-232 or RS-422 control protocols.

Ethernet - 8P8C modular jack (RJ45)

Use this to connect to control network using 10BASE-T or 100Base-TX Ethernet protocol.

GPI - 8P8C modular jack

GPI connector.

COM3 - 8PuC modular jack

Use to connect Multicon in an N-BOX to Flashlink Compact or Flashlink frame (external connectivity when Multicon is not in a Flashlink frame), using RS-422 control protocol.

12.10.2 Hardware revision 4 without SFP

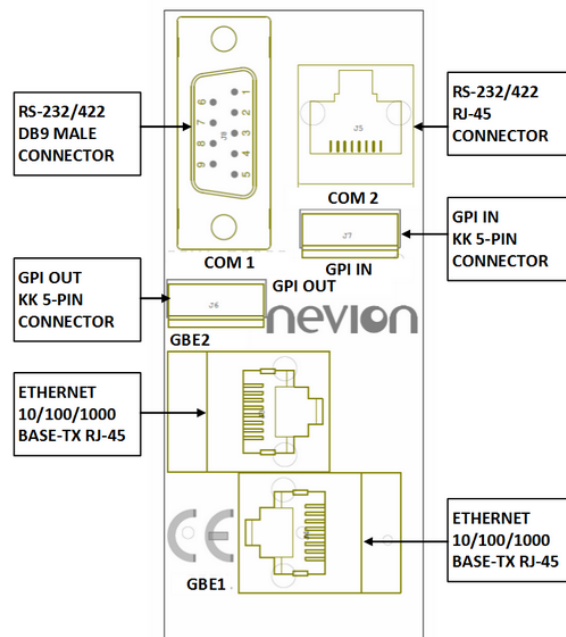

Figure 12.11 Rear-view Mk4 without SFP

The following service connectors can be found on the rear of the Multicon hardware revision 4:

COM1 - DB9 Male serial port (RS-232/422)

Use this to connect either VikinX routers or third party equipment, using RS-232 or RS-422 control protocols.

COM2 - 8P8C modular jack serial port (RS-232/422)

Use this to connect either VikinX routers or third party equipment, using RS-232 or RS-422 control protocols.

GBE1 - 8P8C modular jack (RJ45)

Use this to connect to control network using 10BASE-T, 100BASE-TX or 1000BASE-T Ethernet protocol.

GBE2 - 8P8C modular jack (RJ45)

Use this to connect to control network using 10BASE-T, 100BASE-TX or 1000BASE-T Ethernet protocol.

GPI IN - Molex KK 254 5pin

Use this to connect GPI inputs.

GPI OUT - Molex KK 254 5pin

Use this to connect GPI outputs.

12.10.3 Hardware revision 4 with SFP

Figure 12.12 Rear-view
Mk4 with SFP

P1 - Molex KK 254 5pin

Use this to connect GPI inputs and outputs.

P2 - Molex KK 254 5pin

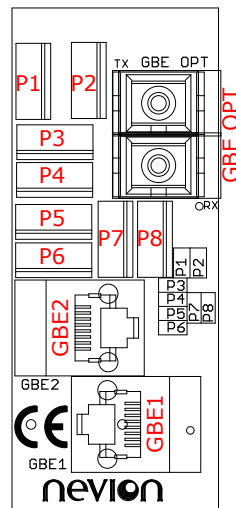
Not in use.

P3 - Molex KK 254 5pin

Use this to connect GPI inputs and outputs.

P4 - Molex KK 254 5pin

Use this to connect either VikinX routers or third party equipment, using RS-232 or RS-422 control protocols.

P5 - Molex KK 254 5pin
Not in use.

P6 - Molex KK 254 5pin
Use this to connect either VikinX routers or third party equipment, using RS-232 or RS-422 control protocols.

P7 - Molex KK 254 5pin
Not in use.

P8 - Molex KK 254 5pin
Not in use.

GBE1 - 8P8C modular jack (RJ45)
Use this to connect to control network using 10BASE-T, 100BASE-TX or 1000BASE-T Ethernet protocol.

GBE2 - 8P8C modular jack (RJ45)
Use this to connect to control network using 10BASE-T, 100BASE-TX or 1000BASE-T Ethernet protocol.

GBE OPT - Dual SC/UPC
Use this to connect to control network using 1000BASE-X.

12.11 GPIO

The GPI output can be used for wiring up alarms for third party control systems. The GPI output will be active, if one or more alarms are active in the local Flashlink system.

The GPI inputs can be used for triggering alarms in Multicon. The alarms can also send SNMP traps and are shown in the alarms list. These inputs can be given custom labels.

12.11.1 Connections (mk2)

The GPI connector is shown in [Figure 12.13](#). The GPI output is an open collector output, sinking to ground when an alarm is triggered.

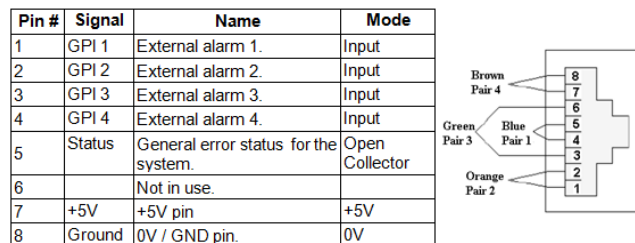

Figure 12.13 GPI pinout

12.11.2 Connections (mk4)

The GPI connectors on mk4 are Molex KK 254 5pin. The pinout is different between Multicon with SFP and without SFP.

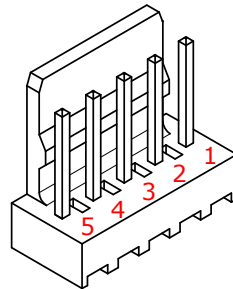

Figure 12.14 Molex KK 254 5pin connector

GPI inputs uses internal pull-up to 3,3V.

GPI outputs uses open collector transistor, sinking to ground when an alarm is triggered. Max voltage is 30V and max current is 100 mA.

Table 12.5 GPI pinout for Multicon without SFP

Pin	GPI IN	GPI OUT
1	Input 4	Not used
2	Input 3	Not used
3	Input 2	Not used
4	Input 1	Output 1
5	GND	GND

Table 12.6 GPI pinout for Multicon with SFP

Pin	P1	P2
1	Not used	Not used
2	Output 1	Not used
3	Input 2	Input 4
4	Input 1	Input 3
5	GND	GND

12.12 Monitor Flashlink Power Supplies (mk2)

It is possible to monitor the Flashlink power supply via Multicon and receive alarms if there is a power failure.

You can monitor the power supply status via the GPI on Multicon backplane. You will have to make a cable and connect this from the relay pins on the DC INPUT/OUTPUT (DC1, DC2) (DB9) connector.

With this cable you can see the alarm status both in the Multicon web interface and using an SNMP Manager. Note that in Multicon you can maximum get 4 GPI alarms.

If you would like Multicon to send the GPI alarms to a SNMP Manager you have to configure the SNMP trap destination under the Settings tab and SNMP setup. Put the IP address of the SNMP Manager under SNMP trap destination.

How-to make the cable:

1. From power 1 (DC1, frame 1): Pin 1 from RJ45, soldered to pin 3 on DB9. Pin 8 from RJ45, soldered to pin 7 on DB9.
2. From power 2 (DC2, frame 1): Pin 2 from RJ45, soldered to pin 3 on DB9. Pin 8 from RJ45, soldered to pin 7 on DB9.
3. From power 1 (DC1, frame 2): Pin 3 from RJ45, soldered to pin 3 on DB9. Pin 8 from RJ45, soldered to pin 7 on DB9.
4. From power 2 (DC2, frame 2): Pin 4 from RJ45, soldered to pin 3 on DB9. Pin 8 from RJ45, soldered to pin 7 on DB9.

Additional info:

See above for more information GPI connections on the Multicon back-plane and page the FR-2RU-10-2 manual for pin-out on DC1 and DC2.

12.13 Serial Connectivity

Connection can be made through the serial port(s) of Multicon; see also the note below for connection details.

The communication parameters are configurable. Please refer to the protocol documentation of the appropriate communication/control protocol.



Note: Note that if the standard RS-232 cable specification (DCE) is followed:

- a cable with Male+Male or Female+Female connectors at the cable ends is used for Rx/Tx crossed connection, and
- a cable with Male+Female connectors at the cable ends is used for a straight through connection.

12.13.1 DB9 connectors

The DB9 connectors for the serial port(s) of the router have the following pinout:

Pin #	COM2 (RS-422) Female connector		COM1 (RS-232) Male connector	
	RS-232 mode	RS-422 mode	RS-232 mode	RS-422 mode
1	Not in use	Not in use	Not in use	Not in use
2	Tx	Tx -	Rx	Rx +
3	Rx	Rx +	Tx	Tx -
4	Not in use	Not in use	Not in use	Not in use
5	GND	GND	GND	GND
6	GND	GND	GND	GND
7	RTS	Tx +	RTS	Tx +
8	CTS	Rx -	CTS	Rx -
9	Do Not Connect!	Do Not Connect!	Do Not Connect!	Do Not Connect!

12.13.2 Molex KK 254 5pin connectors

The Molex KK 254 5pin connectors for the serial ports of the router have pinout described in the following table. Pin numbering is as described in [Figure 12.14](#).

Pin #	Port mode	
	RS-422	RS-232
1	RX+	RX
2	RX-	NC
3	TX+	NC
4	TX-	TX
5	GND	GND

12.13.3 Maximum Cable Length (RS-232)

IEEE has specified the maximum cable length for an RS-232 connection to 15m. Longer distances can be installed depending on the environmental conditions of the installation site.



Note: It is the responsibility of the installation personnel to secure a proper installation of the RS-232 connection.

12.14 Ethernet Connectivity

The connections follow the standard set by the IEEE 802.3 100BaseTX specification. The cables that are to be applied should be CAT-5 / CAT-5E standard, or better.



Note: It is the responsibility of the installation personnel to secure a proper installation of the Ethernet connection.

12.14.1 Ethernet connections on Mk4

Multicon hardware revision 4 has two electrical Ethernet interfaces. If the optional SFP is present, it has also an optical Ethernet interface. These interfaces, and a logical interface connected to Multicon, will form an Ethernet switch. This is illustrated in [Figure 12.15](#). This means that when connecting Multicon to the control network, it is optional which of the interfaces that are used.



Note: The Ethernet switch bandwidth is limited to 400 Mbits/sec. It is the responsibility of the installation personnel to make sure the total traffic on the interfaces is below this limitation.

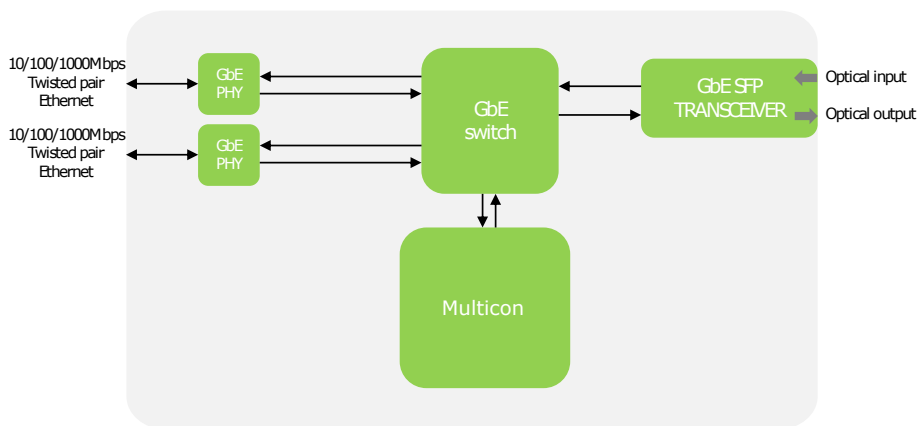

Figure 12.15 Ethernet switch on Mk4.

12.15 External RS422 Flashlink Connectivity

It is possible to connect Multicon in an N-BOX housing to Flashlink Compact units using an RJ45 connector on the back plane of the Multicon card. This is also referred to COM3 in the figure above and provides the ability to connect to the RS422 Flashlink bus externally instead of internally within a frame.

Physically the connection between the COM3 port on the Multicon back plane and the Flashlink Compact units is performed using a Shielded Twisted Pair (STP) Cat5 cable.



Note: To avoid any ground issues with connecting a Multicon in an N-BOX to a Flashlink Compact unit it is required to use Shielded Twisted Pair (STP) Cat5 cables for interconnecting the COM3 port on the Multicon with the Flashlink Compact units.

Multicon in an N-BOX will always appear in frame 0 in the web interface, but you are able to set the slot position using the switch on the back of the N-BOX (see picture below). Please make sure that there is no address overlap between the Multicon in an N-BOX and any Flashlink cards in the system. The safest option is to not configure any connected Flashlink frames of Flashlink Compact units to use frame address 0. For more information about Flashlink frame and Flashlink Compact addressing please refer to respective user manuals.



To use the external RS422 Flashlink bus (COM3), Multicon must be configured to use the external instead of the default internal bus using the Nevion Configurator. The screenshot below shows how to change the setting from internal to external bus connection. The dialog is opened by performing the following steps:

- Open the system including the Multicon controller in Nevion Configurator
- From the System Overview page, right click on the Multicon Controller and select Properties



Note: The option to select internal or external bus connection is only available if the Multicon has been booted in a normal Flashlink frame first with at least one Flashlink card present. This is always the case for Multicon cards delivered by Nevion, as it is part of standard test procedures, but may not be the case for field upgraded units. To overcome this problem please boot the Multicon card in a Flashlink 2RU frame first with one or more Flashlink cards to be able to set the setting to external bus connection.

Appendix A Protocol Specifications

A.1 Modular Router Protocol (MRP)

MRP is NeviON's default protocol for **IP** northbound access (host) from external systems and southbound access (client) to control routers and other integrated devices. Please refer to the MRP protocol specification for further details concerning this protocol.

A.2 NCB Sublime/Compact

This is NeviON's default protocol for **serial** northbound access (host) from external systems and southbound access (client) to control routers and other integrated devices. Please refer to the NCB protocol specification for further details concerning this protocol.

A.3 SNMP

SNMP is supported for monitoring and control of both Flashlink and VikinX routers. Third-party routers integrated with the Multicon controller may also be controlled using the SNMP interface. Please refer to the Multicon SNMP protocol specification for further details concerning this protocol.

A.4 Snell Pro-bel SW-P-02

The Snell Pro-bel SW-P-02 protocol is supported on TCP/IP and serial port (RS422/RS232).

Serial port settings (default):

- Port mode: RS422
- Baud rate: 38400
- Parity: Even
- Data bits: 8
- Stop bits: 1

TCP/IP settings (default):

- Northbound (host):
 - Listens for connections on port 2000
- Southbound (client):
 - Connects to client using port 2000

Multicon supports the following commands for northbound interfaces:

Command Name	Comments
01 INTERROGATE	Responds with 03-TALLY
02 CONNECT	Responds with 04-CONNECTED
03 TALLY	
04 CONNECTED	
05 CONNECT_ON	
06 GO	
12 CON_ON_GO_ACK	
13 GO_DONE_ACK	

In addition, the northbound interface has some response options:

- Response on Pro-Bel crosspoint command:
- Command acknowledge
 - Command and crosspoint switch acknowledge (default)
- Crosspoint switch acknowledge:
- Send TALLY (default)
 - Send CONNECTED

Multicon is using the following commands for southbound interfaces:

Command Name	Comments
01 INTERROGATE	Responds with 03-TALLY
02 CONNECT	Responds with 04-CONNECTED
03 TALLY	
04 CONNECTED	
65 EXT_INTERROGATE	Responds with 67-EXT_TALLY
66 EXT_CONNECT	Responds with 67-EXT_CONNECTED
67 EXT_TALLY	
68 EXT_CONNECTED	

Please also refer to Snell Pro-Bel SW-P-02 protocol documents.

A.5 Leitch Pass-Through

The Leitch Pass-Through protocol is supported on TCP/IP and serial (RS232/RS422).

Serial port settings (default):

- Port mode: RS232
- Baud rate: 9600
- Parity: None

- Data bits: 8
- Stop bits: 1

TCP/IP settings:

- Northbound (host):
 - Listens for connections on port 23 with telnet authentication
 - Username: *leitch*
 - Password: *pt*
 - Listens for connections on port 5023 without user authentication
- Southbound (client):
 - Connects to client using telnet port 23
 - Username and password are configured in NeviON Configurator

Multicon supports the following commands for northbound interfaces:

Command	Name	Comments
00	DISABLE_REPORTING	
01	ENABLE_REPORTING	
02	PRESET_CLEAR	
03	PRESET_EXECUTE	
04	PRESET_XP	
16	PRESET_REQUEST_XP	
17	PRESET_REQUEST_LEVEL	
05	XP_REQUEST_LEVEL	
06	XP_REQUEST_OUTPUT	
07	XP_LOCK	
08	XP_PROTECT	
09	XP_RESET	
10	XP_DIRECT_TAKE	
11	FRAME_SIZE	
12	DEVICE_INFORMATION	
13	ALARM_REQUEST	
14	DEVICE_MSG1	
15	DEVICE_MSG2	

Configuration options for level mapping and device ID in NeviON Configurator. Address is used in Leitch protocol, level is the level number used in Multicon.

Address	Level	Video control
0	1	on
1	2	on
2	3	on
3	4	on
4	5	on
5	6	on
6	7	on
7	8	on
8	9	on
9	10	on
10	11	on
11	12	on
12	13	on
13	14	on
14	15	on
15	16	on

1  Device identifier

Multicon is using the following commands for southbound interfaces:

Command Name	Comments
01	ENABLE_REPORTING
05	XP_REQUEST_LEVEL
10	XP_DIRECT_TAKE
11	FRAME_SIZE

Multicon is always handling lock and protect internally, so there is no need to support lock for the external device.

A.6 Triton

Please refer to the NCB protocol specification for further details concerning this protocol.

A.7 Thomson/Grass Valley Native

The Thomson/Grass Valley Native protocol is supported on TCP/IP and serial (RS232/RS422). Sources and destinations in Native protocol, refer to inputs and outputs on a level in Multicon.

Serial port settings (default):

- Port mode: RS232
- Baud rate: 9600
- Parity: None
- Data bits: 8
- Stop bits: 1

TCP/IP settings:

- Northbound (host):
 - Listens for connections on port 12345
- Southbound (client):
 - Connects to client using TCP/IP port configured in NeviON Configurator

Multicon supports the following commands for northbound interfaces:

Command Name	Comments
BK	Background Activites
QE	Query Error Definition
QH	Query Alarms
QN	Query Names
QC	Query Combined Destination Status
QD / Qd	Query Destination Status
QI / Qi	Query Destination Status – Response type 1
QJ / Qj	Query Destination Status – Response type 2
TA	Request Take
TD	Request Take Destination
TI	Request Take Index with Level Index
TJ	Request Take Index wit Level Bit Map
PR	Request Protect
UP	Request UnProtect

Level mapping is used to handle limitation of 32 levels in Native protocol. Each row has double mapping, one for video (0-15) and one for audio (16-31). In Native protocol doesn't have audio/video, so this is used to get mapping up to 32 levels. Note that chop, tie-line, room and salvo related functionality is not supported for northbound access.

Address	Level	Video control
0	1	on
1	2	on
2	3	on
3	4	on
4	5	on
5	6	on
6	7	on
7	8	on
8	9	on
9	10	on
10	11	on
11	12	on
12	13	on
13	14	on
14	15	on
15	16	on

1  Device Identifier

Multicon is using the following commands for southbound interfaces:

Command	Name	Comments
	BK	
	QN	Uses L, IS and ID arguments (optional argument D)
	TJ	
	Qj	Optional
	UP	If lock is configured in Nevion Configurator
	PR	If lock is configured in Nevion Configurator

Please also refer to Grass Valley - Router Protocol Manual (071020103 – March 2004).

A.8 TSL UMD Protocol

TSL UMD Protocol V3.1 is supported on UDP/IP and serial port (RS232/RS422). For configuration instructions, please contact Nevion Support.

Appendix B General Environmental Requirements for NeviON Equipment

1. The equipment will meet the guaranteed performance specification under the following environmental conditions:
 - Operating room temperature range: 0°C to 45°C
 - Operating relative humidity range: <90% (non-condensing)
2. The equipment will operate without damage under the following environmental conditions:
 - Temperature range: -10°C to 55°C
 - Relative humidity range: <95% (non-condensing)

Appendix C Product Warranty

The warranty terms and conditions for the product(s) covered by this manual follow the General Sales Conditions by NeviON, which are available on the company web site:

<http://www.neviON.com>

Appendix D Materials Declaration and Recycling Information

D.1 Materials Declaration

For product sold into China after 1st March 2007, we comply with the “Administrative Measure on the Control of Pollution by Electronic Information Products”. In the first stage of this legislation, content of six hazardous materials has to be declared. The table below shows the required information.

組成名稱 Part Name	Toxic or hazardous substances and elements					
	鉛 Lead (Pb)	汞 Mercury (Hg)	鎘 Cadmium (Cd)	六价铬 Hexavalent Chromium (Cr(VI))	多溴联苯 Polybrominated biphenyls (PBB)	多溴二苯醚 Polybrominated diphenyl ethers (PBDE)
Multicon	0	0	0	0	0	0
O: Indicates that this toxic or hazardous substance contained in all of the homogeneous materials for this part is below the limit requirement in SJ/T11363-2006. X: Indicates that this toxic or hazardous substance contained in at least one of the homogeneous materials used for this part is above the limit requirement in SJ/T11363-2006.						

This is indicated by the product marking:



D.2 Recycling information

Nevion provides assistance to customers and recyclers through our web site <http://www.nevion.com>. Please contact Nevion Support for assistance with recycling if this site does not show the information you require.

Where it is not possible to return the product to Nevion or its agents for recycling, the following general information may be of assistance:

- Before attempting disassembly, ensure the product is completely disconnected from power and signal connections.
- All major parts are marked or labeled to show their material content.
- Depending on the date of manufacture, this product may contain lead in solder.
- Some circuit boards may contain battery-backed memory devices.

Appendix E EC Declaration of Conformity

MANUFACTURER	<u>Nevion</u>	
AUTHORIZED REPRESENTATIVE (Established within the EEA)	Not applicable	
MODEL NUMBER(S)	<u>Multicon</u>	
DESCRIPTION	<u>Multicon GYDA Flashlink Element Manager</u> <u>Multicon VX-SLC VikinX Sublime System Controller</u> <u>Multicon VX-MOD VikinX Modular System Controller</u>	
DIRECTIVES this equipment complies with	Low voltage (EU Directive 2006/95/EC) EMC (EU Directive 2004/108/EC) <u>RoHS</u> (EU Directive 2002/95/EC) China <u>RoHS</u> ¹ WEEE (EU Directive 2002/96/EC) REACH	
HARMONISED STANDARDS applied in order to verify compliance with Directive(s)	EN 55103-1:1996 EN 55103-2:1996 EN 60950-1:2006	
TEST REPORTS ISSUED BY	Notified/Competent Body	Report no:
	<u>Nemko</u>	10689
TECHNICAL CONSTRUCTION FILE NO	Not applicable	
YEAR WHICH THE CE-MARK WAS AFFIXED	2004	
TEST AUTHORIZED SIGNATORY		
MANUFACTURER	AUTHORIZED REPRESENTATIVE (Established within EEA)	Date of Issue
		2009-08-01
		Place of Issue
	Not applicable	<u>Sandefjord, Norway</u>
 NEVION EUROPE AS O.nr. 976 584 201 MVA		
Name	Thomas Øhrbom	
Position	VP of Business Support Systems, <u>Nevion</u> (authorized signature)	