

Flashlink Compact II

FC-3G-EO-OE-36+2C
FC-3G-OE-36+2C
FC-3G-EO-36+2C

FC-3G-EO-OE-36+1C
FC-3G-EO-36+1C
FC-3G-OE-36+1C
FC-3G-EO-18+1C
FC-OE-18+1C

FC-3G-EO-OE-36
FC-3G-OE-36
FC-3G-EO-36
FC-3G-OE-18
FC-3G-EO-18

User manual

Rev. B

Nezion Support

Nezion Europe

P.O. Box 1020
3204 Sandefjord, Norway
Support phone 1: +47 33 48 99 97
Support phone 2: +47 90 60 99 99

Nezion USA

1600 Emerson Avenue
Oxnard, CA 93033, USA
Toll free North America: (866) 515-0811
Outside North America: +1 (805) 247-8560

E-mail: support@nezion.com

See <http://www.nezion.com/support/> for service hours for customer support globally.

Revision history

Current revision of this document is the uppermost in the table below.

Rev.	Repl.	Date	Sign	Change description
B	A	2015-12-14	SHH	Updated information regarding sales products FC-3G-EO-18+1C and FC-3G-OE-18+1C
A	-	2013-07-03	MS	First official release

Contents

Revision history	2
1 Product overview	4
1.1 Product versions	4
2 Specifications	5
2.1 Front view	7
2.1.1 FC-3G-EO-18.....	7
2.1.2 FC-3G-EO-36.....	8
2.1.3 FC-3G-OE-18.....	9
2.1.4 FC-3G-OE-36.....	10
2.1.5 FC-3G-EO-OE-36	11
2.1.6 CWDM filter placement	12
2.2 Rear view.....	13
2.2.1 FC-3G-EO-18.....	13
2.2.2 FC-3G-EO-36.....	13
2.2.3 FC-3G-OE-18.....	14
2.2.4 FC-3G-OE-36.....	14
2.2.5 FC-3G-EO-OE-36	15
3 Connections	16
1.1.1 Pin-out POWER A and POWER B (DB9)	16
1.2.1 Pin-out RS-422 (RJ45)	16
4 Replacing fan modules	17
5 Configuration	19
5.1 Stand-alone mode.....	19
5.2 Multicon Gyda mode	19
5.2.1 Address setting	19
5.2.2 Multicon Gyda configuration	21
5.2.3 Multicon Gyda information.....	23
6 Upgrade firmware	24
7 Nevion SFP	25
8 Laser safety precautions	26
General environmental requirements for Nevion equipment	27
Product Warranty.....	28
Appendix A Materials declaration and recycling information	29
A.1 Materials declaration.....	29
A.2 Recycling information.....	29

1 Product overview

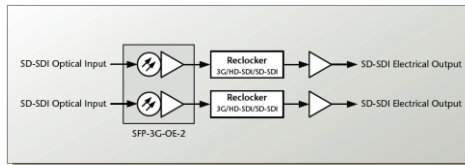

FC-3G-OE

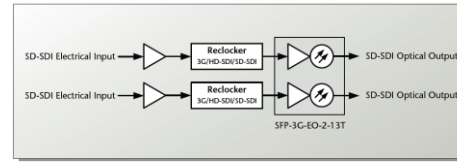

FC-3G-EO

The Flashlink compact II is a range of low power, low price and small form factor optical to electrical converters. It can convert up to 36 channels in 1RU and optically multiplex all channels onto two fibers with the use of two optional 18 channel CWDM filters. Both EO and OE converters have an SD/HD/3G-SDI reclocker and supports bypass for none broadcast bitrates. The Flashlink Compact II can be controlled and monitored by Multicon Gyda or configured to be a standalone converter. The optical conversions are based on Nevion's hot pluggable SFP modules. The Flashlink Compact II is equipped with an extra power inlet for dual power supply redundancy, either from an extra SL-PWR-40/SL-PWR-90, the 1RU FC-PWR or battery pack.

1.1 Product versions

FC-3G-EO-18	18 channel electrical to optical converter
FC-3G-OE-18	18 channel electrical to optical converter
FC-3G-EO-18+1C	18 channel electrical to optical converter+ one CWDM filter
FC-3G-OE-18+1C	18 channel optical to electrical converter + one CWDM filter
FC-3G-EO-36	36 channel electrical to optical converter
FC-3G-OE-36	36 channel optical to electrical converter
FC-3G-EO-OE-36	18 channel optical to electrical converter and 18 channel electrical to optical converter
FC-3G-EO-36+1C	36 channel electrical to optical converter+ one CWDM filter
FC-3G-OE-36+1C	36 channel optical to electrical converter + one CWDM filter
FC-3G-EO-OE-36+1C	18 channel optical to electrical converter and+ one CWDM filter 18 channel electrical to optical converter + one CWDM filter
FC-3G-EO-36+2C	36 channel electrical to optical converter + two CWDM filters
FC-3G-OE-36+2C	36 channel optical to electrical converter + two CWDM filters
FC-3G-EO-OE-36+2C	18 channel optical to electrical converter and 18 channel electrical to optical converter + two CWDM filters

All 18 channel versions are supplied with one SL-PWR-40

All 36 channel versions are supplied with one SL-PWR-90(can be used for all 18 channel versions without damage)

Extra powers supplies can be ordered for all versions.

2 Specifications

General

Power	+12V to 16V DC / 48W, max(standard SFP) 36channel variants 24W, max(standard SFP) 18 channel variants
Size	1.7" x 19" x 7.1" (H x W x D) 43.4mm x 482.6mm x 180.0mm (H x W x D)
Control	Options for Multicon Gyda control and status BITE (Built-In Test Equipment) Status LED in front Configurations DIP in back
Operating temperature	0 to +45 °C
Forced ventilation	Four monitored fans, two on each side. Left to right airflow.
Data rate reclocked:	270, 1485, 1485/1.001, 2970, 2970/1.001 Mbps
Data rate non-reclocked:	1 to 2970 Mbps (Depending on SFP used)

Supported standards

SD, 270Mbps	SMPTE259M
HD, 1485Mbps	SMPTE292-2008
3G, 2999Mbps	SMPTE424M
DVB-ASI	EN50083-9.
Fiber Transmission	SMPTE297-2006
Electrical connector, BC	IEC 61169-8
AES-3id (non-reclocked)	
AES-10/MADI (non-reclocked)	

Optical SDI input

See Nevion SFP datasheets for specification.

Optical SDI output

See Nevion SFP datasheets for specification.

Electrical SDI input

Connectors	BNC, IEC 61169-8
Impedance	75ohm
Cable equalization	Automatic; 350m @270Mbps w/Belden 8281 250m @1485Mbps w/Belden 1694A 150m @ 2970Mbps w/Belden 1694A
Input Return loss	>15dB, 5-1485MHz >10dB, 1485-2970MHz

Electrical SDI outputs

Connectors	BNC, IEC 61169-8
Impedance	75ohm
Output signal level	800mV +/- 10%
Output signal rise / fall time	20% - 80% - SD, 0.4ns – 1.5ns, <0.5ns rise/fall variation - HD/3G, < 270ps, <100ps rise/fall variation
DC-offset	0V +/-0,5
Amplitude overshoot	<10%
Output return loss	>15dB, 5-1485MHz >10dB, 1485-2970MHz

18 channel CWDM filter

Number of channels	18
Available wavelengths (nm)	1271, 1291, 1311, 1331, 1351, 1371, 1391, 1411, 1431, 1451, 1471, 1491, 1511, 1531, 1551, 1571, 1591, 1611
Connector	LC/UPC
Insertion loss (end to end, including connectors)	5dB typical 6dB max
Channel Spacing	20nm
Passband	13nm min
Transmission circuit fibre	9/125um single mode
Adjacent Channel Isolation	30dB min
Non-Adjacent Channel Isolation	40dB min
Directivity	45dB min
Connector Return loss	45dB min
Polarization depending loss	0.2dB max
Ripple in passband	0.5dB max
Operating Temperature	0 – 70 °C
Storage Temperature	-40 – 85 °C
Optical Power	17mW max

2.1 Front view

2.1.1 FC-3G-EO-18



- Power A indicator:** Gives status on power supply connected to the Power A connector on the back side.
- Green: Power supply connected
 - Orange: No or none working power supply connected
 - Red: The lower converter is malfunctioning. Please contact Nevision support for advice.
- Power B indicator:** Gives status on power supply connected to the Power B connector on the back side.
- Green: Power supply connected
 - Orange: No or none working power supply connected
 - Red: The lower converter is malfunctioning. Please contact Nevision support for advice.
- 1 to 18 indicators:** Gives status per SFP converter channel.
- Green: Valid input signal and reclocker in lock or bypass.
 - Orange: Signal on input, but reclocker not in lock.
 - Red: No valid input signal.
 - No light: No valid Nevision SFP present.
- SFP:** Cage for fitting dual transmitter non-MSA SFPs.

2.1.2 FC-3G-EO-36



- Power A indicator:** Gives status on power supply connected to the Power A connector on the back side.
- Green: Power supply connected
 - Orange: No or none working power supply connected
 - Red: The lower converter is malfunctioning. Please contact Nevion support for advice.
- Power B indicator:** Gives status on power supply connected to the Power B connector on the back side.
- Green: Power supply connected
 - Orange: No or none working power supply connected
 - Red: The lower converter is malfunctioning. Please contact Nevion support for advice.
- 1 to 18 indicators:** Gives status per SFP converter channel.
- Green: Valid input signal and reclocker in lock or bypass.
 - Orange: Signal on input, but reclocker not in lock.
 - Red: No valid input signal.
 - No light: No valid Nevion SFP present.
- Upper SFP:** Cage for fitting dual transmitter non-MSA SFPs.
- Lower SFP:** Cage for fitting dual transmitter non-MSA SFPs.

2.1.3 FC-3G-OE-18



- Power A indicator:** Gives status on power supply connected to the Power A connector on the back side.
- Green: Power supply connected
 - Orange: No or none working power supply connected
 - Red: The lower converter is malfunctioning. Please contact Nevision support for advice.
- Power B indicator:** Gives status on power supply connected to the Power B connector on the back side.
- Green: Power supply connected
 - Orange: No or none working power supply connected
 - Red: The lower converter is malfunctioning. Please contact Nevision support for advice.
- 1 to 18 indicators:** Gives status per SFP converter channel.
- Green: Valid input signal and reclocker in lock or bypass.
 - Orange: Signal on input, but reclocker not in lock.
 - Red: No valid input signal.
 - No light: No valid Nevision SFP present.
- SFP:** Cage for fitting dual receivers, non-MSA SFPs .

2.1.4 FC-3G-OE-36



- Power A indicator:** Gives status on power supply connected to the Power A connector on the back side.
- Green: Power supply connected
 - Orange: No or none working power supply connected
 - Red: The lower converter is malfunctioning. Please contact Nevision support for advice.
- Power B indicator:** Gives status on power supply connected to the Power B connector on the back side.
- Green: Power supply connected
 - Orange: No or none working power supply connected
 - Red: The lower converter is malfunctioning. Please contact Nevision support for advice.
- 1 to 18 indicators:** Gives status per SFP converter channel.
- Green: Valid input signal and reclocker in lock or bypass.
 - Orange: Signal on input, but reclocker not in lock.
 - Red: No valid input signal.
 - No light: No valid Nevision SFP present.
- Upper SFP:** Cage for fitting dual receivers non-MSA SFPs.
- Lower SFP:** Cage for fitting dual receivers non-MSA SFPs.

2.1.5 FC-3G-EO-OE-36



The receiver module is always the upper row and the transmitter module always the lower row.

- Power A indicator:** Gives status on power supply connected to the Power A connector on the back side.
- Green: Power supply connected
 - Orange: No or none working power supply connected
 - Red: The lower converter is malfunctioning. Please contact Nevision support for advice.
- Power B indicator:** Gives status on power supply connected to the Power B connector on the back side.
- Green: Power supply connected
 - Orange: No or none working power supply connected
 - Red: The lower converter is malfunctioning. Please contact Nevision support for advice.
- 1 to 18 indicators:** Gives status per SFP converter channel.
- Green: Valid input signal and reclocker in lock or bypass.
 - Orange: Signal on input, but reclocker not in lock.
 - Red: No valid input signal.
 - No light: No valid Nevision SFP present.
- Upper SFP:** Cage for fitting dual receivers non-MSA SFPs.
- Lower SFP:** Cage for fitting dual transmitters non-MSA SFPs.

2.1.6 CWDM filter placement

The CWDM filters included in some of the variant are mounted in the front from the right.

FC-3G-EO-OE-36+1C, FC-3G-EO-36+1C, FC-3G-OE-36+1C, FC-3G-EO-18+1C and FC-3G-OE-18+1C



FC-3G-EO-OE-36+2C, FC-3G-EO-36+2C and FC-3G-OE-36+2C



2.2 Rear view

2.2.1 FC-3G-EO-18

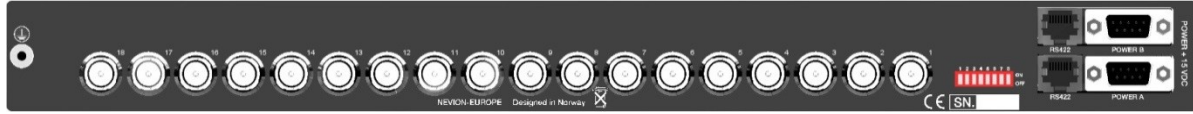

- Earth point: For connection to internal earth bar in 19"
- BNC: Electrical 3G/HD/SD-SDI inputs.
- DIP 1 to 8: Configures the Flashlink Compact II. See chapter 5 for more information.

Upper RS422: RJ45 connector for connection for Multicon Gyda.

Lower RS422: RJ45 connector for daisy chaining more Flashlink Compact II. This must be terminated when not used.

Power A: Main DC input connector. Standard 9pin DSUB. Pin 4 is positive voltage and pin 1 is ground.

Power B: Spare/redundancy DC input connector. Standard 9pin DSUB. Pin 4 is positive voltage and pin 1 is ground.

2.2.2 FC-3G-EO-36

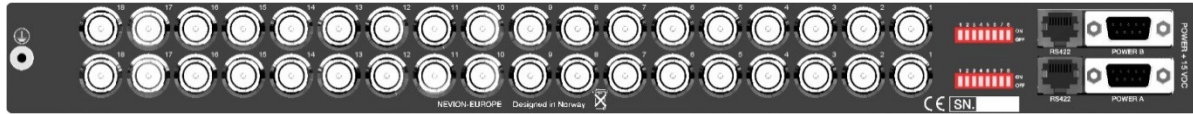

- Earth point: For connection to internal earth bar in 19"
- Upper BNC: Electrical 3G/HD/SD-SDI inputs.
- Lower BNC: Electrical 3G/HD/SD-SDI inputs.
- DIP 1 to 8: Configures the Flashlink Compact II. See chapter 5 for more information. (upper and lower)

Upper RS422: RJ45 connector for connection for Multicon Gyda.

Lower RS422: RJ45 connector for daisy chaining more Flashlink Compact II. This must be terminated when not used.

Power A: Main DC input connector. Standard 9pin DSUB. Pin 4 is positive voltage and pin 1 is ground.

Power B: Spare/redundancy DC input connector. Standard 9pin DSUB. Pin 4 is positive voltage and pin 1 is ground.

2.2.3 FC-3G-OE-18



- Earth point: For connection to internal earth bar in 19"
- BNC: Electrical 3G/HD/SD-SDI outputs.
- DIP 1 to 8: Configures the Flashlink Compact II. See chapter 5 for more information.

Upper RS422: RJ45 connector for connection for Multicon Gyda.

Lower RS422: RJ45 connector for daisy chaining more Flashlink Compact II. This must be terminated when not used.

Power A: Main DC input connector. Standard 9pin DSUB. Pin 4 is positive voltage and pin 1 is ground.

Power B: Spare/redundancy DC input connector. Standard 9pin DSUB. Pin 4 is positive voltage and pin 1 is ground.

2.2.4 FC-3G-OE-36

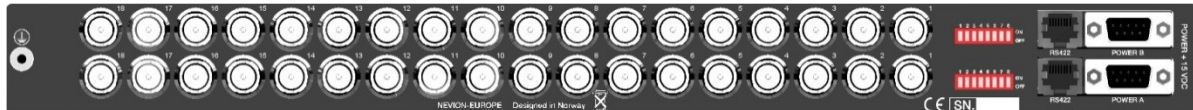

Earth point: For connection to internal earth bar in 19"

Upper BNC: Electrical 3G/HD/SD-SDI outputs.

Lower BNC: Electrical 3G/HD/SD-SDI outputs.

DIP 1 to 8: Configures the Flashlink Compact II. See chapter 5 for more information. (upper and lower)

Upper RS422: RJ45 connector for connection for Multicon Gyda.

Lower RS422: RJ45 connector for daisy chaining more Flashlink Compact II. This must be terminated when not used.

Power A: Main DC input connector. Standard 9pin DSUB. Pin 4 is positive voltage and pin 1 is ground.

Power B: Spare/redundancy DC input connector. Standard 9pin DSUB. Pin 4 is positive voltage and pin 1 is ground.

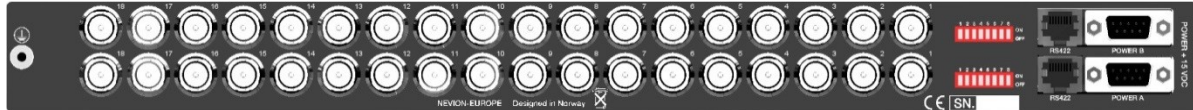
2.2.5 FC-3G-EO-OE-36

The optical to electrical is always the upper row and the electrical to optical is always the lower row.

- Earth point: For connection to internal earth bar in 19"
- Upper BNC: Electrical 3G/HD/SD-SDI outputs.
- Lower BNC: Electrical 3G/HD/SD-SDI inputs.
- DIP 1 to 8: Configures the Flashlink Compact II. See chapter 5 for more information. (upper and lower)
- Upper RS422: RJ45 connector for connection for Multicon Gyda.
- Lower RS422: RJ45 connector for daisy chaining more Flashlink Compact II. This must be terminated when not used.
- Power A: Main DC input connector. Standard 9pin DSUB. Pin 4 is positive voltage and pin 1 is ground.
- Power B: Spare/redundancy DC input connector. Standard 9pin DSUB. Pin 4 is positive voltage and pin 1 is ground.

3 Connections

1.1 Power connection

Figure 3 shows the power connections of the unit as well as the RS-422 connections.

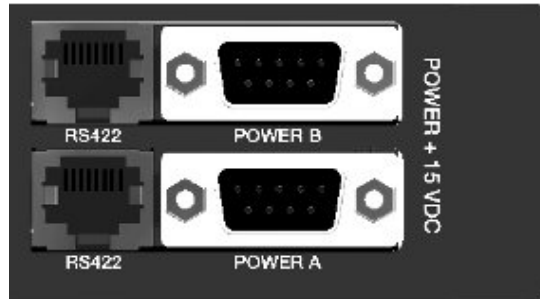

Figure 1 - Connector module for the power supply.

The Power inputs are constructed to provide redundancy when using two external power supplies. When supplying power to one of the connectors it is not possible to source power from the second power connector. Tighten the screws to ensure a proper contact.

The power inputs are DB9 male connectors.

1.1.1 Pin-out POWER A and POWER B (DB9)

Pin #1	GND
Pin #4	+15V

1.2 RS-422 connection

At the rear of unit it is two RJ45 connectors. These are used for Flashlink RS422 control bus.

The RS-422 interfaces are shown in figure 3.

1.2.1 Pin-out RS-422 (RJ45)

Pin #1	Rx A (+)
Pin #2	Rx B (-)
Pin #3	Tx A (+)
Pin #4	Reserved
Pin #5	Reserved
Pin #6	Tx B (-)
Pin #7	Not Connected
Pin #8	Not Connected

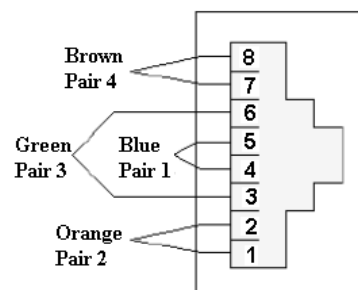

4 Replacing fan modules

Flashlink Compact II will report an alarm in Multicon Gyda if any of the fans are failing. Fan 1 & 2 are right side fan module and fan 3 & 4 are left side fan module.

Before replacing one of the fan modules, ensure that you have the right variant available.

There are two different variants, one for left side and one for the right side. Use the pictures below as a reference.



Figure 2 – Left side fan module (fan 3 & 4)

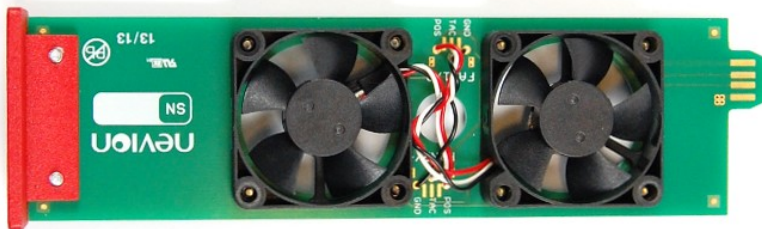
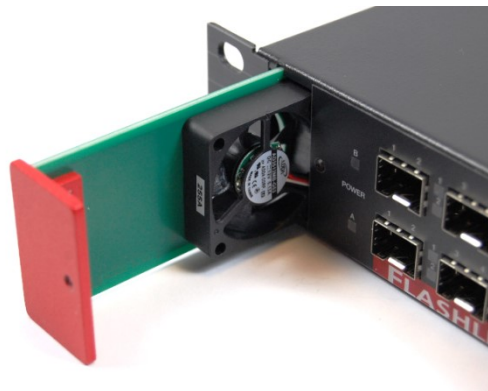

Figure 3 – right side fan module (fan 1 & 2)

When replacing the fan module. Remove the screw fastening the red front cover and pull the fan module out. Replace it with a new module and secure with the screw.





5 Configuration

Flashlink Compact II can operate in two modes, Stand alone and Multicon Gyda controlled mode. This setting is set by switch 8 on the back of the Flashlink Compact II.

5.1 Stand-alone mode

The Flashlink Compact II is configured to transport SD/HD/3G-SDI with reclocked set to auto. Switch 1 to 7 has no function in this mode.

5.2 Multicon Gyda mode

In this mode configuration can be done by Multicon Gyda. Each of the converter boards in the Flashlink Compact unit will come up as separate Flashlink cards in Multicon. The frame and slot address is setup by dip switches 1 to 7. Each slot must be set to a unique sub-rack and slot address.

In order to ensure proper operation of the system, it is important that no sub-racks or Flashlink Compact II controlled by the same Multicon Gyda have the same address set.

5.2.1 Address setting

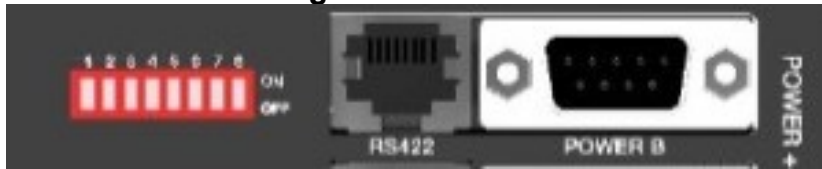

The switches 1-3 set the sub-rack address:

SW1	SW2	SW3	Sub-rack
OFF	OFF	OFF	0
ON	OFF	OFF	1
OFF	ON	OFF	2
ON	ON	OFF	3
OFF	OFF	ON	4
ON	OFF	ON	5
OFF	ON	ON	6
ON	ON	ON	7

The switches 4-7 set the slot address:

SW4	SW5	SW6	SW7	Slot
OFF	OFF	OFF	OFF	1
ON	OFF	OFF	OFF	2
OFF	ON	OFF	OFF	3
ON	ON	OFF	OFF	4
OFF	OFF	ON	OFF	5
ON	OFF	ON	OFF	6
OFF	ON	ON	OFF	7
ON	ON	ON	OFF	8
OFF	OFF	OFF	ON	9
ON	OFF	OFF	ON	10
OFF	ON	OFF	ON	Not allowed
ON	ON	OFF	ON	Not allowed
OFF	OFF	ON	ON	Not allowed
ON	OFF	ON	ON	Not allowed
OFF	ON	ON	ON	Not allowed
ON	ON	ON	ON	Not allowed

A power recycling is need after a change in address.

5.2.2 Multicon Gyda configuration

The Flashlink Compact II does not store configuration set from Multicon Gyda.

This means that the Flashlink Compact II will after a power recycling receive stored parameters from Multicon Gyda.

5.2.2.1 Card label

Card label	<input type="text"/>	Locate Card	<input type="text"/> sec
-------------------	----------------------	-------------	--------------------------

Assigns a name. When the locate is pushed all indicators on front of the Flashlink Compact II will flash for 120 seconds, alternative an period can be enter into the sec box.

5.2.2.2 Firmware upgrade

Firmware upgrade	Upload file: <input type="text" value="None"/>	Upload
-------------------------	--	--------

Updates the firmware on Flashlink Compact II. The firmware file first has to be uploaded to Multicon Gyda by ftp. See user manual on Multicon Gyda for help on uploading.

5.2.2.3 Electrical input

Electrical input 1	<input checked="" type="radio"/> Normal	<input type="radio"/> EQ Bypass
---------------------------	---	---------------------------------

For 3G/HD/SD-SDI and ASI signals set the electrical input to normal. For MADI and low bit rate signals set this to EQ bypass.

Alarm	Upper limit	Lower limit	Alarm	SNMP trap
Electrical input 1			<input checked="" type="radio"/> Normal <input type="radio"/> Ignore	<input type="radio"/> Send <input checked="" type="radio"/> Ignore

The alarm handling for the electrical input can be turn on or off by the normal and ignore radio button. Also the SNMP alarm trap can be turn on or off by send or ignore radio button.

5.2.2.4 Electrical output

Electrical output 1	<input type="radio"/> On	<input type="radio"/> Auto	<input checked="" type="radio"/> Off
----------------------------	--------------------------	----------------------------	--------------------------------------

Turns on and off the output signal. When in auto mode the state of reclocker controls the output state. If reclocker is in lock then output is on, else output is off. If reclocker is in bypass the output is on.

5.2.2.5 Reclocker

Reclocker 1	<input checked="" type="radio"/> Enable	<input type="radio"/> Bypass	Autobypass: <input checked="" type="radio"/> On <input type="radio"/> Off
--------------------	---	------------------------------	---

For SDI signal set to enable, else set to bypass. Autobypass only works if the reclocker is enabled. With autobypass on the reclocker will set the reclocker in bypass mode when none SDI signal is detected.

Alarm	Upper limit	Lower limit	Alarm	SNMP trap
Reclocker 1			<input checked="" type="radio"/> Normal <input type="radio"/> Ignore	<input type="radio"/> Send <input checked="" type="radio"/> Ignore

The alarm handling for the reclocker can be turn on or off by the normal and ignore radio button. Also the SNMP alarm trap can be turn on or off by send or ignore radio button.

5.2.2.6 Optical input

No configurable parameters.

Alarm	Upper limit	Lower limit	Alarm	SNMP trap
Optical input 1			<input checked="" type="radio"/> Normal <input type="radio"/> Ignore	<input type="radio"/> Send <input checked="" type="radio"/> Ignore

The alarm handling for the optical input can be turn on or off by the normal and ignore radio button. Also the SNMP alarm trap can be turn on or off by send or ignore radio button.

5.2.2.7 Optical output

Optical output 1	<input checked="" type="radio"/> On <input type="radio"/> Off
-------------------------	---

Turns on or off the optical output. For safety reason turn off none used optical ports.

Alarm	Upper limit	Lower limit	Alarm	SNMP trap
Optical output 1			<input checked="" type="radio"/> Normal <input type="radio"/> Ignore	<input type="radio"/> Send <input checked="" type="radio"/> Ignore

The alarm handling for the optical output can be turn on or off by the normal and ignore radio button. Also the SNMP alarm trap can be turn on or off by send or ignore radio button.

5.2.2.8 Voltage Power A and B

This is the external DC power inlet on the backside of the Flashlink Compact II.

Alarm	Lower limit	Upper limit	Alarm	SNMP trap
Voltage Power A	10000 mV	17000 mV	<input checked="" type="radio"/> Normal <input type="radio"/> Ignore	<input type="radio"/> Send <input checked="" type="radio"/> Ignore
Voltage Power B	10000 mV	17000 mV	<input checked="" type="radio"/> Normal <input type="radio"/> Ignore	<input type="radio"/> Send <input checked="" type="radio"/> Ignore

The alarm handling for the external voltages can be can be turn on or off by the normal and ignore radio button. Also the SNMP alarm trap can be turn on or off by send or ignore radio button.

5.2.2.9 Voltage (3.3V) Internal A and B

This is the internal voltages in Flashlink Compact II.

Alarm	Lower limit	Upper limit	Alarm	SNMP trap
Voltage (3.3V) Internal A	3100 mV	3500 mV	<input checked="" type="radio"/> Normal <input type="radio"/> Ignore	<input type="radio"/> Send <input checked="" type="radio"/> Ignore
Voltage (3.3V) Internal B	3100 mV	3500 mV	<input checked="" type="radio"/> Normal <input type="radio"/> Ignore	<input type="radio"/> Send <input checked="" type="radio"/> Ignore

The alarm handling for the external voltages can be can be turn on or off by the normal and ignore radio button. Also the SNMP alarm trap can be turn on or off by send or ignore radio button.

5.2.2.10 Voltage (12V) Fan

This is the internal voltage for fans in Flashlink Compact II.

Alarm	Lower limit	Upper limit	Alarm	SNMP trap
Voltage (12V) Fan	10800 mV	13200 mV	<input checked="" type="radio"/> Normal <input type="radio"/> Ignore	<input type="radio"/> Send <input checked="" type="radio"/> Ignore

The alarm handling for the external voltages can be can be turn on or off by the normal and ignore radio button. Also the SNMP alarm trap can be turn on or off by send or ignore radio button.

5.2.2.11 Card version

This box gives information on serial number and the firmware used in the Flashlink Compact II. Always state this when contacting Nevia support.

Card version	
hw	1.0
lib	1.2.1
serial	2171307220200634
sw	1.2.78

5.2.3 Multicon Gyda information



Flashlink Compact 18ch EO converter

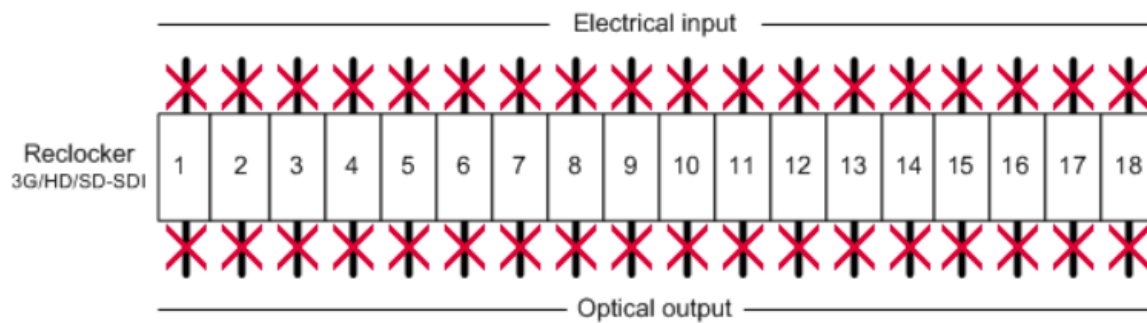

On top of the Multicon Gyda information tab a dynamical picture of the Flashlink Compact II is displayed. The red cross will automatically update reflecting the status on the Flashlink Compact II. Table below describe the meaning of the red cross:

- Electrical input: Red cross means no electrical input present.
- Electrical output: Red cross means reclocker not in lock or electrical output turned off.
- Optical input: Red cross means no optical input present or no SFP present.
- Optical output: Red cross means reclocker not in lock or no SFP present.

6 Upgrade firmware

For upgrading the firmware the switch 8 has to be set to on; Multicon Gyda mode. The address also has to be set correctly according to chapter 5.2.1. See Multicon Gyda manual for instructions on upgrading Flashlink card.

7 Nevion SFP

A list of valid Nevion SFP for the Flashlink Compact II with Nevion ordering number.:

Ordering code	Name	Description
19145	SFP-3G-OE-2	Dual receiver SFP
22180	SFP-3G-OE-2-L	Dual receiver SFP, long haul
19244	SFP-3G-EO-2-C1310/C1550	Dual Transmitter LC, 1310/1550nm
19245	SFP-3G-EO-2-C1270/C1290	Dual Transmitter LC, 1270/1290nm
19246	SFP-3G-EO-2-C1310/C1330	Dual Transmitter LC, 1310/1330nm
19247	SFP-3G-EO-2-C1350/C1370	Dual Transmitter LC, 1350/1370nm
19248	SFP-3G-EO-2-C1390/C1410	Dual Transmitter LC, 1390/1410nm
19249	SFP-3G-EO-2-C1430/C1450	Dual Transmitter LC, 1430/1450nm
19250	SFP-3G-EO-2-C1470/C1490	Dual Transmitter LC, 1470/1490nm
19251	SFP-3G-EO-2-C1510/C1530	Dual Transmitter LC, 1510/1530nm
19252	SFP-3G-EO-2-C1550/C1570	Dual Transmitter LC, 1550/1570nm
19253	SFP-3G-EO-2-C1590/C1610	Dual Transmitter LC, 1590/1610nm

Changing SFP can be done without removing power

8 Laser safety precautions

These are guidelines to limit hazards from laser exposure.

All the available EO units in the Flashlink range include a laser.

Therefore this note on laser safety should be read thoroughly even though there is no laser onboard this product.

The lasers emit light at wave lengths between 1271 nm and 1611 nm. This means that the human eye cannot see the beam, and the blink reflex cannot protect the eye. (The human eye can see light between 400 nm to 700 nm).

A laser beam can be harmful to the human eye (depending on laser power and exposure time). Therefore:

Be careful when connecting / disconnecting fiber pigtails (ends).
Never look directly into the pigtail of the laser/fiber.
Never use microscopes, magnifying glasses or eye loupes to look into a fiber end.
Use laser safety goggles blocking light between 1271 nm and at 1611 nm

Instruments exist to verify light output power: Power meters, IR-cards etc.

Flashlink features:

The Flashlink Compact II is designed as Class 1 laser product according to EN 60 825-1:94/A11:96, and class IIIb according to CFR Ch1 (1997) Part 1040.10.

Maximum output power¹: < 17 mW

Operating wavelengths: > 1260 nm

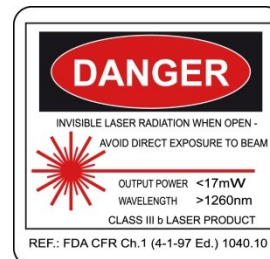

¹ Max power is for safety analysis only and does not represent device performance.

General environmental requirements for Nevion equipment

1. The equipment will meet the guaranteed performance specification under the following environmental conditions:
 - Operating room temperature range: 0°C to 45°C
 - Operating relative humidity range: <90% (non-condensing)

2. The equipment will operate without damage under the following environmental conditions:
 - Temperature range: -10°C to 55°C
 - Relative humidity range: <95% (non-condensing)

Product Warranty

The warranty terms and conditions for the product(s) covered by this manual follow the General Sales Conditions by Nevion, which are available on the company web site:

www.nevion.com

Appendix A Materials declaration and recycling information

A.1 Materials declaration

For product sold into China after 1st March 2007, we comply with the “Administrative Measure on the Control of Pollution by Electronic Information Products”. In the first stage of this legislation, content of six hazardous materials has to be declared. The table below shows the required information.

組成名稱 Part Name	Toxic or hazardous substances and elements					
	鉛 Lead (Pb)	汞 Mercury (Hg)	鎘 Cadmium (Cd)	六价铬 Hexavalent Chromium (Cr(VI))	多溴联苯 Polybrominated biphenyls (PBB)	多溴二苯醚 Polybrominated diphenyl ethers (PBDE)
FC-3G-EO-OE-36+2C FC-3G-EO-36+1C FC-3G-EO-OE-36+1C FC-3G-EO-36+2C FC-3G-EO-36+2C FC-3G-EO-36 FC-3G-EO-36 FC-3G-EO-OE-36 FC-3G-EO-18 FC-3G-EO-18 FC-3G-EO-36+1C	○	○	○	○	○	○
SL-PWR-40 SL-PWR-90	○	○	○	○	○	○

O: Indicates that this toxic or hazardous substance contained in all of the homogeneous materials for this part is below the limit requirement in SJ/T11363-2006.

X: Indicates that this toxic or hazardous substance contained in at least one of the homogeneous materials used for this part is above the limit requirement in SJ/T11363-2006.

This is indicated by the product marking:



A.2 Recycling information

Nevion provides assistance to customers and recyclers through our web site <http://www.nevion.com/>. Please contact Nevion’s Customer Support for assistance with recycling if this site does not show the information you require.

Where it is not possible to return the product to Nevion or its agents for recycling, the following general information may be of assistance:

- Before attempting disassembly, ensure the product is completely disconnected from power and signal connections.
- All major parts are marked or labeled to show their material content.
- Depending on the date of manufacture, this product may contain lead in solder.
- Some circuit boards may contain battery-backed memory devices.