

# **AES/EBU Digital Audio Routers in the VikinX Sublime series**

## **User manual**

Rev. 18

## Nevion Support

Nevion Europe

P.O. Box 1020  
3204 Sandefjord, Norway

Support phone 1: +47 33 48 99 97  
Support phone 2: +47 90 60 99 99

Nevion USA

1600 Emerson Avenue  
Oxnard, CA 93033, USA

Toll free North America: (866) 515-0811  
Outside North America: +1 (805) 247-8560

E-mail: [support@nevion.com](mailto:support@nevion.com)

See <http://www.nevion.com/support/> for service hours for customer support globally.

## Revision history

Current revision of this document is the uppermost in the table below.

Rev.	Repl.	Date	Sign	Change description
18	17	2011-08-22	NBS	Updated Chapter 7.1.2.
17	16	2011-07-14	NBS	Added Appendix B. Added Grass Valley Native Protocol in Chapter 3.6 and Appendix B.2. Added Chapter 7.1.10. Changed Chapter 7.1.1. Updated Declaration of Conformity.
16	15	2011-03-29	NBS	Added Chapter 2.1.1. Updated Chapters 3.6, 4.2 and 7.1.8. Updated wiring information in Chapter 6.3. Corrected housing and gender spec on D-sub 9-pin contacts. Updated Declaration of Conformity. Removed old Revision history.
15	14	2009-09-24	NBS	Updated Chapter 5.2 with new information about Ethernet connectivity. Added extra information about "A/V Toggle" button in Chapter 7.
14	13	2009-01-16	NBS	Added information about 75 ohms unbalanced AES.
13	12	2008-11-21	NBS	Removed GPI information; Added information about programming of 16x2 CPs.

## Contents

1 Product overview .....	4
1.1 Product versions .....	4
2 Specifications .....	6
2.1 Mechanics .....	6
2.2 Power Supply .....	6
2.3 Control.....	6
2.4 Digital Audio specifications .....	7
2.5 Connection details .....	8
3 Configuration .....	9
3.1 Router level .....	9
3.2 Router mode.....	9
3.3 Power alarm .....	14
3.4 Power-up mode .....	14
3.5 Configuring output on Single bus panels .....	15
3.6 Configuring protocol options .....	15
4 LED status indication .....	17
4.1 Start-up .....	17
4.2 Alarm states .....	17
4.3 Ethernet states .....	17
5 Router communication.....	18
5.1 Serial connection .....	18
5.2 Ethernet connection.....	19
5.3 NCB connection .....	20
6 Connecting signal cables to the router.....	22
6.1 Audio signals .....	22
6.2 75-Ohm unbalanced routers .....	23
6.3 Input extension .....	23
7 Control Panel operation .....	27
7.1 Button description.....	27
General environmental requirements for Nevia equipment.....	30
Product Warranty.....	31
Important notes regarding Software in the VikinX Sublime router family range .....	32
Appendix A Materials declaration and recycling information.....	33
Appendix B Additional Protocol information.....	34
EC Declaration of Conformity .....	36

## 1 Product overview

Nevion are proud to present the 2nd generation of the compact small and medium routing switcher family, Sublime. With Sublime, Nevision now provide a stable and proven product line including the most complete signal format and size offering available.

With the new ultra slim, multi format and flexible product range, Sublime fulfills the most demanding requirements from the professional broadcast market.

This User Manual presents the features, installation and operation procedures of the AES/EBU Digital Audio routers of the Sublime range.

- Router range from 8x8 to 128x128
- Software based Configurator for easy system set-up
- TCP/IP, RS-232 and NCB Control (RJ-45)
- Programmable multi- single- and dual bus control panels
- Ultra Slim frame depth
- Low Power, high reliability design
- Redundant power supply system with front indicators
- Interoperability with existing VikinX routers
- Future proof and flexible product range

VikinX Sublime provides many of the powerful control features that drove the VikinX Modular range to success. VikinX Sublime is ideal for general purpose facilities, on-air routing, mobile outside broadcast applications and sophisticated A/V applications.

### 1.1 Product versions

The following versions of the VikinX Sublime Digital Audio routers are available:

#### Digital Audio – 19” - 1RU, depth 5cm:

SL-AD0808-110 /	8x8 Digital Audio Router (balanced). Router partitioning,
SL-AD0808-110-CP	programmable X-Y control panel (on CP version).
SL-AD0808-75 /	8x8 Digital Audio Router (unbalanced). Router partitioning,
SL-AD0808-75-CP	programmable X-Y control panel (on CP version).
SL-AD1616-110 /	16x16 Digital Audio Router (balanced). Router partitioning,
SL-AD1616-110-CP	programmable X-Y control panel (on CP version).
SL-AD1616-75 /	16x16 Digital Audio Router (unbalanced). Router partitioning,
SL-AD1616-75-CP	programmable X-Y control panel (on CP version).
SL-AD1602-110 /	16x2 Digital Audio Router (balanced). Programmable Dual Bus
SL-AD1602-110-CP	control panel (on CP version). Expandable to 128x2.
SL-AD1602-75 /	16x2 Digital Audio Router (unbalanced). Programmable Dual Bus
SL-AD1602-75-CP	control panel (on CP version). Expandable to 64x2.

#### Digital Audio – 19” - 2RU, depth 5cm:

SL-AD3232-110 /	32x32 Digital Audio Router (balanced). Router partitioning,
SL-AD3232-110-CP	programmable X-Y control panel (on CP version).
SL-AD3232-75 /	32x32 Digital Audio Router (unbalanced). Router partitioning,
SL-AD3232-75-CP	programmable X-Y control panel (on CP version).

#### Digital Audio – 19” - 4RU, depth 5cm:

SL-AD6464-110 /	64x64 Digital Audio Router (balanced). Router partitioning,
SL-AD6464-110-CP	programmable X

SL-AD6464-75 /                      64x64 Digital Audio Router (unbalanced). Router partitioning,  
SL-AD6464-75-CP                      programmable X

**Available Control Panels – 19” – 1RU:**

SL-16XY-CP                      Multi bus X-Y 16x16 panel.  
SL-8XY-CP                      Multi bus X-Y 8x8 panel.  
SL-16D-CP                      Dual bus 16x2 panel.  
SL-32S-CP                      Single bus 32x1 panel.  
SL-32S-CP-GPI                      Single bus 32x1 panel with GPI / Joystick / Tally interface.  
SL-16S-CP                      Single bus 16x1 panel.  
SL-16S-CP-GPI                      Single bus 16x1 panel with GPI / Joystick / Tally interface.  
SL-8S-CP                      Single bus 8x1 panel.  
SL-8S-CP-GPI                      Single bus 8x1 panel with GPI / Joystick / Tally interface.

**Available Control Panels – 19” – 2RU:**

SL-32XY-CP                      Multi bus X-Y 32x32 panel.  
SL-64S-CP                      Single bus 64x1 panel.  
SL-64S-CP-GPI                      Single bus 64x1 panel with GPI / Joystick / Tally interface.

**Available Control Panels – 19” – 4RU:**

SL-64XY-CP                      Multi bus X-Y 64x64 panel.

## 2 Specifications

### 2.1 Mechanics

Dimensions:	- HxWxD = 44x483x50mm, (19", 1RU);
	- HxWxD = 88x483x50mm, (19", 2RU);
	- HxWxD = 176x483x50mm, (19", 4RU).
Safety/Emission standards:	Compliant with CE EN55103-1 and 2.

#### 2.1.1 Weight and power consumption

Device	Weight, incl. 1x PSU	Current +15V	Current -15V	Power
SL-AD6464-110	2.8 kg	140 mA	3 mA	2 W
SL-AD6464-110-CP	3.5 kg	1100 mA	3 mA	17 W
SL-AD6464-75	3.5 kg	1000 mA	900 mA	29 W
SL-AD6464-75-CP	4.2 kg	2000 mA	900 mA	44 W
SL-AD3232-110	1.7 kg	111 mA	3 mA	2 W
SL-AD3232-110-CP	2.0 kg	630 mA	3 mA	9 W
SL-AD3232-75	1.9 kg	610 mA	490 mA	17 W
SL-AD3232-75-CP	2.2 kg	800 mA	490 mA	19 W
SL-AD1616-110	1.1 kg	150 mA	3 mA	2 W
SL-AD1616-110-CP	1.3 kg	250 mA	3 mA	4 W
SL-AD1616-75	1.2 kg	280 mA	160 mA	7 W
SL-AD1616-75-CP	1.4 kg	350 mA	120 mA	7 W
SL-AD0808-110	1.1 kg	215 mA	3 mA	3 W
SL-AD0808-110-CP	1.2 kg	250 mA	3 mA	4 W
SL-AD0808-75	1.2 kg	210 mA	90 mA	5 W
SL-AD0808-75-CP	1.3 kg	320 mA	90 mA	6 W
SL-AD1602-110	1.1 kg	148 mA	3 mA	2 W
SL-AD1602-110-CP	1.2 kg	246 mA	2 mA	4 W
SL-AD1602-75	1.2 kg	187 mA	6 mA	3 W
SL-AD1602-75-CP	1.3 kg	460 mA	60 mA	8 W

### 2.2 Power Supply

SL-PWR-90	90W Power Supply Unit for SL-AD6464-75(-CP).
SL-PWR-40	40W Power Supply Unit for all other SL-AD versions.
AC Supply voltage range:	100-240VAC, 50-60Hz, Max 1.6A (SL-PWR-40) / Max 3A (SL-PWR-90).
AC Mains connector:	IEC 320.
DC output:	- +15V, max. 2.2A / -15V, max 1.35A. Maximum 43W for 8x8 – 32x32 versions; - +15V, max. 4A / -15V, max 2.5A. Maximum 90W for 64x64 versions.
DC connector:	DE9, D-sub 9-pin male.
Status monitoring:	Via LED in front of the router/CP.
Safety standards:	Compliant with CE EN60950, UL-1950/CSA22.2.

### 2.3 Control

#### Standard Features:

Serial port:	RS-232 for protocol conversion, to VikinX compact control protocol, or to third party protocols.
Connector:	DE9, D-sub 9-pin female.
NCB ports:	For integration with VikinX compact router configuration.
Connectors (2):	RJ45 (1 In / 1 Out)

Ethernet port:	10/100BaseT Ethernet bus for external router control.
Connector:	RJ45.
Synchronization <sup>1</sup> :	<ul style="list-style-type: none"> <li>- Analog Black&amp;Burst, looped. Both PAL and NTSC supported.</li> <li>- Tri-Level, Looped. For HD signal formats only.</li> <li>- Distribution of synchronization signals between several routers.</li> </ul>
Connector(s):	BNC.
<b>Optional Features:</b>	
Control Panel:	<ul style="list-style-type: none"> <li>- Optional, built-in control panel available.</li> <li>- External control panels available.</li> </ul>

## 2.4 Digital Audio specifications

### Reference inputs<sup>1</sup>:

Number of inputs:	1.
Connector:	75 ohm BNC female, loop-thru.
Return loss:	>40dB (100 kHz – 5 MHz); >35dB (5-10 MHz).
Signal format:	NTSC or PAL Black&Burst.
Signal level:	Nominal 1.0Vp-p.
Field selectivity:	Field 1.
Timing range:	<ul style="list-style-type: none"> <li>- PAL: within clock-intervals (27MHz) 565 – 835 in line 6</li> <li>- NTSC: within clock-intervals (27MHz) 565 – 835 in line 10.</li> </ul>

### 2.4.1 110 ohm balanced routers

#### Supported formats:

Broadcast:	<ul style="list-style-type: none"> <li>- AES3 Balanced Digital Audio</li> <li>- LTC time code.</li> </ul>
------------	---

#### Electrical signal specifications:

Connector:	DB25 female.
Input Impedance:	110 ohm $\pm 20\%$ .
Output impedance:	110 ohm $\pm 20\%$ .
Input level tolerance:	200mVpp to 7Vpp.
Output level:	2Vpp < Vo < 7Vpp.
Output jitter:	< 0.025UI.

### 2.4.2 75 ohm unbalanced routers

#### Supported formats:

Broadcast:	<ul style="list-style-type: none"> <li>- AES Unbalanced Digital Audio</li> <li>- LTC time code.</li> </ul>
------------	--

#### Electrical signal specifications:

Connector:	75 ohm BNC female.
Input Impedance:	75 ohm nominal.
Output impedance:	75 ohm nominal.
Input level tolerance:	200mVpp to 7Vpp.
Output level:	2Vpp < Vo < 7Vpp.
Output jitter:	< 0.025UI.

<sup>1</sup> Synchronization of an audio router is not necessary, but an available feature for users who intend to switch this router synchronized to video, using video synchronization signals.

## 2.5 Connection details

The Sublime routers have the following service connections on the rear of each product:

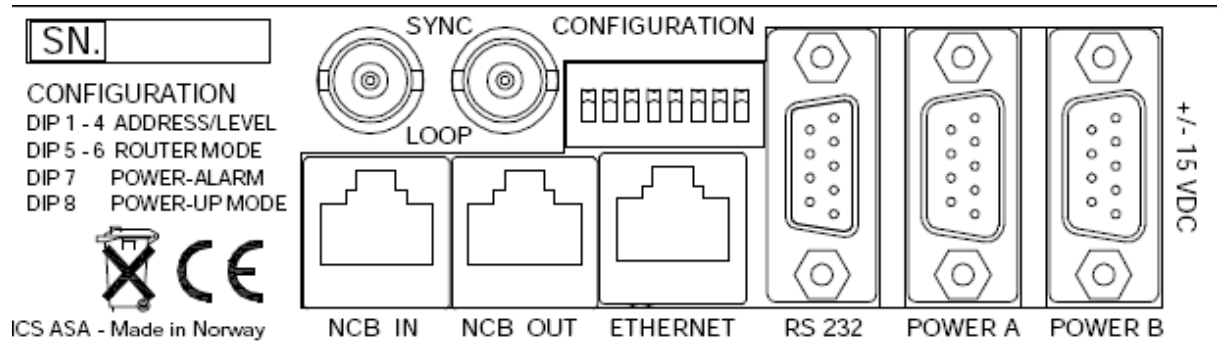

Figure 1: Sublime service connectors.

<b>SYNC<sup>2</sup>:</b>	Synchronization signal (in). Black burst/composite/tri-level sync reference input with passive loop-through for vertical interval switching.
<b>LOOP:</b>	Synchronization signal (out). Loop-through of SYNC input.
<b>NCB IN:</b>	Network Control Bus Input. The protocol of this bus is described in a separate manual.
<b>NCB OUT:</b>	Network Control Bus Output.
<b>ETHERNET:</b>	10/100Base-T Ethernet bus for external router control.
<b>RS 232:</b>	RS-232 for external control protocols.
<b>POWER A:</b>	±15VDC power connector.
<b>POWER B:</b>	±15VDC power connector, redundant supply.
<b>CONFIGURATION:</b>	Configurations switch. See Chapter 3 for further descriptions.

### 2.5.1 Power Supply pinout

The DE9 male sockets for the power connection on Sublime routers and Control Panels have the following pin-out;

Pin #	Description
1	GND
2	Not connected
3	Not connected
4	+15VDC
5	Not connected
6	Not connected
7	Not connected
8	-15VDC
9	Not connected

<sup>2</sup> Synchronization of an audio router is not necessary, but an available feature for users who intend to switch this router synchronized to video, using video synchronization signals.



## 3 Configuration

This chapter provides an overview of the configuration options that are available on the Sublime Digital Audio Routers.

### 3.1 Router level

Switches 1 - 4 on the configuration switch set the router's level for communication with the Router Management System and other units in the NCB system. The panels on the NCB dedicated to operate with the router must be configured to the same level as that router.

If several routers are combined to form an Audio Follow Video, RGB or similar system, these routers must be configured to the same level.

The levels can be switched according to the following pattern:

SW 1	SW 2	SW 3	SW 4	Level	NCB Address
OFF	OFF	OFF	OFF	1	0
OFF	OFF	OFF	ON	2	1
OFF	OFF	ON	OFF	3	2
OFF	OFF	ON	ON	4	3
OFF	ON	OFF	OFF	5	4
OFF	ON	OFF	ON	6	5
OFF	ON	ON	OFF	7	6
OFF	ON	ON	ON	8	7
ON	OFF	OFF	OFF	9	8
ON	OFF	OFF	ON	10	9
ON	OFF	ON	OFF	11	10
ON	OFF	ON	ON	12	11
ON	ON	OFF	OFF	13	12
ON	ON	OFF	ON	14	13
ON	ON	ON	OFF	15	14
ON	ON	ON	ON	16	15

Default level is 1.

### 3.2 Router mode

#### 3.2.1 Router mode on NxN square routers

The Sublime A/V router allows switching in different modes:

Router layers	8x8 router	16x16 router	32x32 router	64x64 router
1 layer	8x8	16x16	32x32	64x64
2 layers	4x4	8x8	16x16	32x32
3 layers	N.A.	5x5	10x10	21x21
4 layers	2x2	4x4	8x8	16x16

Switches 5 - 6 on the configuration switch set the router's mode. The Router Management System software must be configured according to the mode chosen on the router.

The modes can be switched according to the following pattern:

SW 5	SW 6	Router mode
OFF	OFF	1 router layer
OFF	ON	2 router layers
ON	OFF	3 router layers
ON	ON	4 router layers

Default mode is 1 router layer.

Based on the configuration above, the I/O is connected to the router according to the following scheme, where the physical limitations depend on the type of router that is purchased (8x8, 16x16, 32x32 or 64x64):

- **1 layer:**  
I/O is connected according to information on the rear of the router.

- **2 layers, based on an 8x8 router:**

Layer 1	Input	Layer 1	Output
1	1	1	1
2	2	2	2
3	3	3	3
4	4	4	4
Layer 2	Input	Layer 2	Output
1	5	1	5
2	6	2	6
3	7	3	7
4	8	4	8

- **2 layers, based on a 16x16 router:**

Layer 1	Input	Layer 1	Output
1	1	1	1
2	2	2	2
3	3	3	3
4	4	4	4
...	...	...	...
8	8	8	8
Layer 2	Input	Layer 2	Output
1	9	1	9
2	10	2	10
3	11	3	11
4	12	4	12
...	...	...	...
8	16	8	16

- **2 layers, based on a 32x32 router:**

Layer 1	Input	Layer 1	Output
1	1	1	1
2	2	2	2
3	3	3	3
4	4	4	4
...	...	...	...
16	16	16	16
Layer 2	Input	Layer 2	Output
1	17	1	17
2	18	2	18
3	19	3	19
4	20	4	20
...	...	...	...
16	32	16	32

- **2 layers, based on a 64x64 router:**

Layer 1	Input	Layer 1	Output
1	1	1	1
2	2	2	2
3	3	3	3

4	4	4	4
...	...	...	...
32	32	32	32
<b>Layer 2</b>	<b>Input</b>	<b>Layer 2</b>	<b>Output</b>
1	33	1	33
2	34	2	34
3	35	3	35
4	36	4	36
...	...	...	...
32	64	32	64

- 3 layers, based on a 16x16 router:

<b>Layer 1</b>	<b>Input</b>	<b>Layer 1</b>	<b>Output</b>
1	1	1	1
2	2	2	2
3	3	3	3
4	4	4	4
5	5	5	5
<b>Layer 2</b>	<b>Input</b>	<b>Layer 2</b>	<b>Output</b>
1	6	1	6
2	7	2	7
3	8	3	8
4	9	4	9
5	10	5	10
<b>Layer 3</b>	<b>Input</b>	<b>Layer 3</b>	<b>Output</b>
1	11	1	11
2	12	2	12
3	13	3	13
4	14	4	14
5	15	5	15

In-/Output 16 is not in use in this router setup (3 router layers, based on a 16x16 router).

- 3 layers, based on a 32x32 router:

<b>Layer 1</b>	<b>Input</b>	<b>Layer 1</b>	<b>Output</b>
1	1	1	1
2	2	2	2
3	3	3	3
...	...	...	...
10	10	10	10
<b>Layer 2</b>	<b>Input</b>	<b>Layer 2</b>	<b>Output</b>
1	11	1	11
2	12	2	12
3	13	3	13
...	...	...	...
10	20	10	20
<b>Layer 3</b>	<b>Input</b>	<b>Layer 3</b>	<b>Output</b>
1	21	1	21
2	22	2	22
3	23	3	23
...	...	...	...
10	30	10	30

In-/Outputs 31 and 32 are not in use in this router setup (3 router layers, based on a 32x32 router).

- 3 layers, based on a 64x64 router:

Layer 1	Input	Layer 1	Output
1	1	1	1
2	2	2	2
3	3	3	3
...	...	...	...
21	21	21	21
Layer 2	Input	Layer 2	Output
1	22	1	22
2	23	2	23
3	24	3	24
...	...	...	...
21	42	21	42
Layer 3	Input	Layer 3	Output
1	43	1	43
2	44	2	44
3	45	3	45
...	...	...	...
21	63	21	63

In-/Output 64 is not in use in this router setup (3 router layers, based on a 64x64 router).

- 4 layers, based on an 8x8 router:

Layer 1	Input	Layer 1	Output
1	1	1	1
2	2	2	2
Layer 2	Input	Layer 2	Output
1	3	1	3
2	4	2	4
Layer 3	Input	Layer 3	Output
1	5	1	5
2	6	2	6
Layer 4	Input	Layer 4	Output
1	7	1	7
2	8	2	8

- 4 layers, based on a 16x16 router:

Layer 1	Input	Layer 1	Output
1	1	1	1
2	2	2	2
3	3	3	3
4	4	4	4
Layer 2	Input	Layer 2	Output
1	5	1	5
2	6	2	6
3	7	3	7
4	8	4	8
Layer 3	Input	Layer 3	Output
1	9	1	9
2	10	2	10

3	11	3	11
4	12	4	12
<b>Layer 4</b>	<b>Input</b>	<b>Layer 4</b>	<b>Output</b>
1	13	1	13
2	14	2	14
3	15	3	15
4	16	4	16

- 4 layers, based on a 32x32 router:

<b>Layer 1</b>	<b>Input</b>	<b>Layer 1</b>	<b>Output</b>
1	1	1	1
2	2	2	2
...	...	...	...
8	8	8	8
<b>Layer 2</b>	<b>Input</b>	<b>Layer 2</b>	<b>Output</b>
1	9	1	9
2	10	2	10
...	...	...	...
8	16	8	16
<b>Layer 3</b>	<b>Input</b>	<b>Layer 3</b>	<b>Output</b>
1	17	1	17
2	18	2	18
...	...	...	...
8	24	8	24
<b>Layer 4</b>	<b>Input</b>	<b>Layer 4</b>	<b>Output</b>
1	25	1	25
2	26	2	26
...	...	...	...
8	32	8	32

- 4 layers, based on a 64x64 router:

<b>Layer 1</b>	<b>Input</b>	<b>Layer 1</b>	<b>Output</b>
1	1	1	1
2	2	2	2
...	...	...	...
16	16	16	16
<b>Layer 2</b>	<b>Input</b>	<b>Layer 2</b>	<b>Output</b>
1	17	1	17
2	18	2	18
...	...	...	...
16	32	16	32
<b>Layer 3</b>	<b>Input</b>	<b>Layer 3</b>	<b>Output</b>
1	33	1	33
2	34	2	34
...	...	...	...
16	48	16	48
<b>Layer 4</b>	<b>Input</b>	<b>Layer 4</b>	<b>Output</b>
1	49	1	49
2	50	2	50
...	...	...	...
16	64	16	64

### 3.2.2 Router extension mode on 16x2 routers

Switches 5 - 6 on the configuration switch set the router's input offset in systems with 2 or more 16x2 Sublime routers. You may build routers up to 128x2 with audio signal formats, except for SL-AD1602 that may be extended to 64x2. The chosen input offset defines the input range each 16x2 router works on.

Configurable panels cannot detect input offset on 16x2 routers. It is therefore important to remember to re-program the local control panel on 16x2 routers with input offset >0. See also Chapter 7 for more information.

The modes of the *SL-AD1602-110(-CP)* routers can be switched according to the following pattern:

SW 5	SW 6	SW 8	Input offset
OFF	OFF	OFF	0 (Inputs 1-16)
OFF	OFF	ON	1 (Inputs 17-32)
OFF	ON	OFF	2 (Inputs 33-48)
OFF	ON	ON	3 (Inputs 49-64)
ON	OFF	OFF	4 (Inputs 65-80)
ON	OFF	ON	5 (Inputs 81-96)
ON	ON	OFF	6 (Inputs 97-112)
ON	ON	ON	7 (Inputs 113-128)

The modes of the *SL-AD1602-75(-CP)* routers can be switched according to the following pattern:

SW 5	SW 6	SW 8	Input offset
OFF	OFF	ON	0 (Inputs 1-16)
OFF	ON	ON	1 (Inputs 17-32)
ON	OFF	ON	2 (Inputs 33-48)
ON	ON	ON	3 (Inputs 49-64)

Default mode for both routers is 0 offset.

### 3.3 Power alarm

The power alarm can be switched according to the following pattern:

SW 7	Power alarm
OFF	Disables Power Alarm
ON	Enables Power Alarm

Default setting is Power Alarm disabled.

### 3.4 Power-up mode

Switch 8 on the configuration switch defines the power up mode on NxN square routers. The Sublime router provides two modes for powering up the system.

The power up options can be switched according to the following pattern:

SW 8	Power Up mode
OFF	Switches all outputs according to the buffered information in the routers processor system.
ON	Switches all outputs to input 1.

Default setting switches all outputs according to the buffered information in the routers processor system.

### 3.5 Configuring output on Single bus panels

See Chapter 7.1, section Input for configuring default output to be controlled from a Single bus control panel.

### 3.6 Configuring protocol options

For various reasons, Nevia has decided to make it possible to turn the extra commands that were added to the NCB protocol when we introduced the Sublime router range either off or on.

At the same time, the user must select whether he/she shall use the RS-232 port for controlling the router or the Ethernet port. This is done in order to prevent both ports from simultaneously being applied for controlling the router.

There is a new Protocol field in the System Configurator where you may choose from the following options;

- **NCB without Sublime ext. (RS232)**  
This is the “old” Compact NCB protocol, without Sublime extensions. If used on a Sublime, it also disables the Ethernet port of that device.  
This is the default option for the *Sublime Compact* (SC) range of products.
- **NCB (RS232)**  
This is the regular Sublime protocol, with the extra commands that were added to the NCB protocol. If used on a Sublime, it also disables the Ethernet port of that device.  
This is the default option for the *Sublime* (SL) range of products.
- **MRP (TCP/IP)**  
This option is only applicable to the Sublime range. It selects the Ethernet protocol as the control option, and disables the RS-232 port of that device.

Note that the above selection is only possible if you have Sublime FW rel. 2.1.1 (or newer) installed on your Sublime device.

Note also that the above selection can only be made via System Configurator rel. 3.3.5 (or newer) installed on your PC.

It is NOT possible to select protocol options on Sublimes with HW rev. 1.

- **Leitch Pass-Through (RS-232)**  
This option allows support for Leitch Pass-Through protocol via RS-232 interface. The details of this protocol are described in *Leitch Routing Switchers Serial Protocol Reference, Edition E*. See also Appendix B.1 for details.

This option is not supported over NCB.

- **Leitch Pass-Through (TCP/IP)**  
This option allows support for Leitch Pass-Through protocol via TCP/IP interface. The details of this protocol are described in *Leitch Routing Switchers Serial Protocol Reference, Edition E*.  
The interface is using port 23 for this protocol option; same port as for Telnet applications. See also Appendix B.1 for details.

It is not possible to apply the Leitch Pass-Through protocol on TCP/IP and RS-232 simultaneously.

The Leitch Pass-Through selections are only available on Sublime routers with FW version 2.4.x and higher.

The Leitch Pass-Through protocols are only configurable via the Nevia Configurator.

– **Grass Valley Native protocol (TCP/IP)**

This option allows support for Grass Valley Native protocol via TCP/IP interface, using port 12345. The subset of this protocol that is supported by Sublime routers and control panels is described in Appendix B.2.

The Grass Valley Native protocol is only available on Sublime routers with FW version 2.5.4 and higher.

– **Sublime 16x2 routers with, or without extensions**

This option shall be used only on 16x2 routers, enabling both IP, or RS-232 control and NCB extensions to other 16x2 routers in a stack.

When using 16x2 routers in a stack, the router with the highest offset shall be connected to IP, or RS-232; and the rest of the stack interconnected with NCB connections.

See Chapter 6.3 for connection details.

This protocol option is *only* used on 16x2 routers; but should be used on *all* 16x2 routers in the application.

Use your System Configurator to verify the HW revision of your Sublime unit:

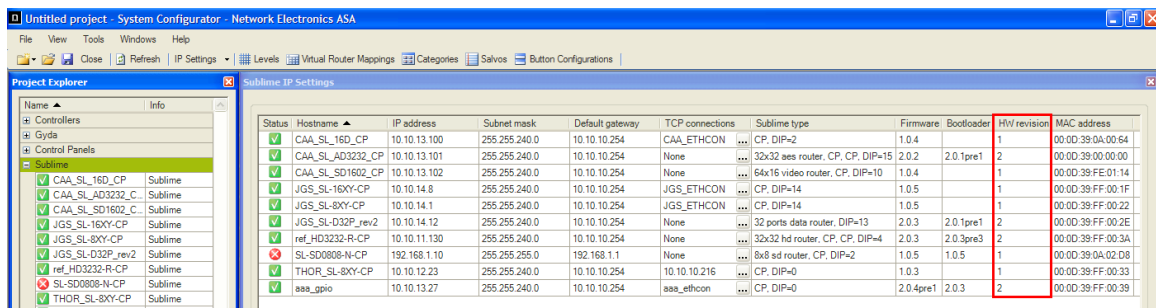

Figure 2: HW verification in Nevia Configurator.

Right-click the column headers and select the appropriate column to be shown, if you don't see the appropriate column in your default display.

For further information about FW releases, please go to the Nevia web site to download, or check available FW releases: [www.nevia.com](http://www.nevia.com).



## 4 LED status indication

### 4.1 Start-up

The LED located at the front of the router indicates the status of the router. At start-up, the LED will alternate between red (R) and green (G) every 500ms for about two seconds. After the start-up sequence the LED will indicate the Alarm state of the router.

There are two LEDs located at the Ethernet bus. At start-up the boot loader is searching for update commands on the serial port for about two seconds. During this sequence both Ethernet LEDs will be blinking. After the start-up sequence the LEDs will indicate the Ethernet state.

### 4.2 Alarm states

The LED can either be red (R), green (G), yellow (Y) or have no light (N).

The LED state is here described with twenty letters, each representing 100ms, which totals to an alarm sequence of two seconds. The X indicates that the LED keeps the color it has the moment the alarm sequence begins (green, yellow or no light).

Description	LED state	Alarm	Comment
Continuous green light	GGGGG GGGGG GGGGG GGGGG	No alarm. Status is OK.	
Continuous yellow light	YYYYY YYYYY YYYYY YYYYY	Unable to connect to controller over Ethernet.	This alarm will be overwritten by other alarms
Long red blinks	RRRRR NNNNN RRRRR NNNNN	Power is too low.	
One short red blink	RXXXX XXXXX XXXXX XXXXX	Power A failed	Only active if power alarm dip is set.
Two short red blinks	XXXXX XXXXX RXRXX XXXXX	Power B failed	Only active if power alarm dip is set.
Red with one short yellow blink	YRRRR RRRRR RRRRR RRRRR	No valid product key.	
Red with two short yellow blinks	YRYRR RRRRR RRRRR RRRRR	SFP error.	Only used on routers with optical modules.

### 4.3 Ethernet states

The LEDs that are located at the Ethernet bus will after the Start-up sequence indicate the Ethernet states:

	On	Off / Blinking
Green	Valid link	No link
Yellow	No data	Data is transmitted or received

## 5 Router communication

You gain access to router for communication purposes by connecting either the router's serial port to your computer or by using an Ethernet connection.

Do not use both the router's Ethernet port and RS-232 serial port, or NCB ports, at the same time. Doing so may cause loss of important communication and control data.

### 5.1 Serial connection

Connection can be made through the serial port of the router; see also Chapter 2.5 for connection details.

The communication parameters are configurable. Please refer to the protocol documentation of the appropriate communication/control protocol.

Example: The protocol parameters of the *VikinX Compact routers* are as follows:

- Bit rate 19200 bit/s
- Data bits 8 bits
- Stop bits 1
- Parity: No parity

For further details concerning this protocol, please refer to the following manual:

[NCB Protocol.pdf](#).

The DE9 female socket for the serial port of the router has the following pin-out:

Pin #	RS-232 mode
1	<i>Not in use</i>
2	Tx
3	Rx
4	<i>Not in use</i>
5	GND
6	GND
7	RTS
8	CTS
9	<i>Do Not Connect!</i>

Note that if the standard RS-232 cable specification (DCE) is followed:

A cable with Male+Male or Female+Female connectors at the cable ends is used for Rx/Tx crossed connection, and

A cable with Male+Female connectors at the cable ends is used for a straight through connection.

#### 5.1.1 Maximum cable length (RS-232)

IEEE has specified the maximum cable length for an RS-232 connection to 15m. Longer distances can be installed depending on the environmental conditions of the installation site.

It is the responsibility of the installer / user to secure a proper installation of the RS-232 connection.

## 5.2 Ethernet connection

The connections follow the standard set by the IEEE 802.3 100BaseTX specification. The cables that are to be applied should be CAT-5 / CAT-5E standard, or better. It is the responsibility of the installer / user to secure a proper installation of the Ethernet connection.

All VikinX Sublime routers and IP-based Control Panels are connected together through an Ethernet Switch.

A VikinX Sublime device has only one physical Ethernet connection. If redundant control is required, this limitation has to be solved by the control system.

For Ethernet protocol details concerning this router, please refer to the following manual: Modular Router Control Protocol. This manual can be found on our web site: <http://www.nevion.com>.

### 5.2.1 HW limitations

With the introduction of Sublime controller HW Rev.2, the user has the option of connecting more than two devices together, without having a Multicon to control the network. See Chapter 3.6 for verification of the HW revision of your device.

Unless you apply a Multicon as a system controller, the limitations that apply are:

1. One Sublime control panel may connect to a maximum of 4 Sublime routers.
2. One Sublime router may be controlled by a maximum of 4 Sublime control panels.

Exceptions to the above limitations:

A router with a local CP (e.g. SL-V6464-CP) may only connect to 1 other router. Both routers must be configured with the same address and be of different type (A+V).

Example: 1x SL-V6464-CP may only control itself + 1x Audio router (AA or AES). Both routers must be configured with the same address.

16x2 routers that are expanded to NNx2 (see Chapters 3.2.2 and 3.4) are using the NCB bus for this purpose. The total NNx2 router is therefore counted as 1 router in the limitations 1 and 2 above.

From limitations 1 and 2 above, the resulting Ethernet configuration may consist of maximum 8 devices; 4 routers and 4 control panels, with the exceptions mentioned above. An example is illustrated in the figure below.

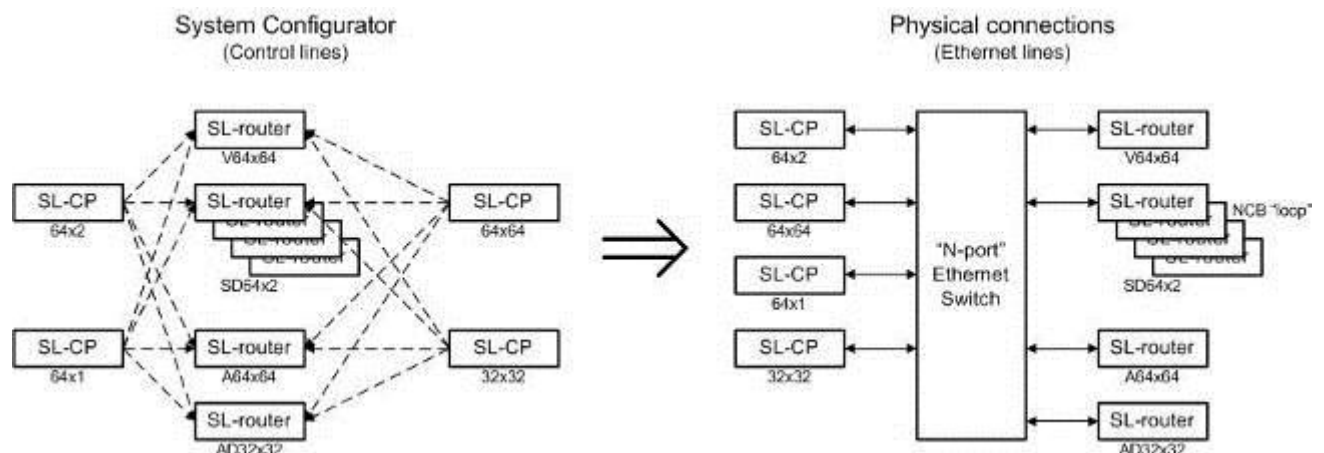

Figure 3: Ethernet connections and configuration.

Refer to the System Configurator User Manual for further information about the above described configuration/connection options.

It is NOT possible to connect more than 2x Sublimes with HW rev. 1 together via Ethernet, unless a Multicon is applied as system controller.

### 5.3 NCB connection

Via the Network Control Bus system several routers and control panels can be interconnected.

Up to 16 levels of routers, or combinations of routers, can be controlled. The NCB system and all RS 232 ports interchange the system status. This means that any control system, either from Nevision, or from a third party manufacturer, connected to any RS 232 port in the NCB loop, will have access to all communication data on the bus.

#### 5.3.1 Connecting control panels

To get a control panel working with a specific router, configure the control panel to the same level as the router. Several panels can be configured to control the same router. Panels can also be connected to a router via the RS-232 interface. Please refer to your control panel manual for installation.

#### 5.3.2 Pin-out and cable type

VikinX Sublime routers and Control Panels use RJ45 connectors for the Network Control Bus ports. The following pin-out is used:

- Pin #1 Not Connected
- Pin #2 Not Connected
- Pin #3 Data (retour)
- Pin #4 Data
- Pin #5 Data
- Pin #6 Data (retour)
- Pin #7 Not Connected
- Pin #8 Not Connected

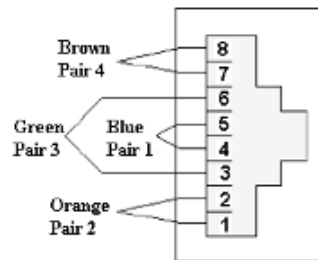

The following connection example shows connection of 4 VikinX devices with RJ45 connectors and bus termination:

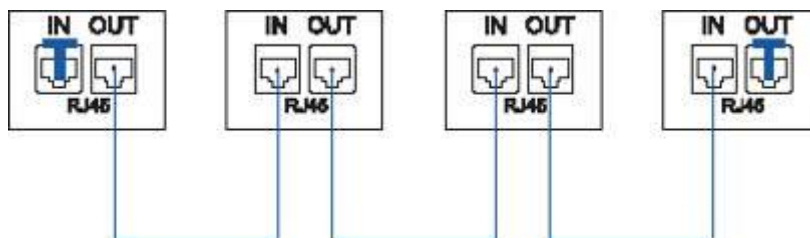

**Figure 4: NCB loop configuration.**

Note that each device at the end of the chain has a termination plug, indicated with the letter "T". This termination plug must be inserted in the correct connection port. If not, no NCB communication is possible.

#### 5.3.3 Termination plug

The termination plug that is mentioned in the previous chapter is necessary when you want to avoid closing the loop by a (long) cable.

The termination plug is a standard RJ45 plug with the following internal wiring:



**Figure 5: NCB loop termination plug.**

As seen in the figure above, *Pin 3* is connected to *Pin 4*, and *Pin 5* is connected to *Pin 6*.

### **5.3.4 Control bus structure**

The Network Control Bus structure follows the standard MIDI bus definition. The NCB is defined as a closed chain of units. This means that the NCB OUT of the last unit must be connected to the NCB IN of the first unit in the NCB chain. To avoid problems with the control of VikinX units the installer/user has to assure that the bus structure is installed according to this definition.

The total number of VikinX devices in an NCB chain is limited to 50.

### **5.3.5 Maximum distance between NCB devices**

The standard MIDI definition allows a maximum cable length of 200-250 meters between two devices. Longer distances can be made with MIDI repeater units. To avoid grounding problems all NCB ports have opto-coupled inputs.

## 6 Connecting signal cables to the router

### 6.1 Audio signals

Our standard pin-out for DB25 audio contacts is shown below. This pin-out is used for both analog and digital audio routers.

Channel #	DB25 Pin #		
	Hot (+)	Cold (-)	GND
1	24	12	25
2	10	23	11
3	21	9	22
4	7	20	8
5	18	6	19
6	4	17	5
7	15	3	16
8	1	14	2

All audio contacts used on the routers are female type.

The following sub-chapters indicate the order of the connectors on the rear of the audio routers.

#### 6.1.1 SL-AD6464-110

Connect your audio cables according to the following table:

49-56	57-64	49-56	57-64
INPUT		OUTPUT	
33-40	41-48	33-40	41-48
INPUT		OUTPUT	
17-24	25-32	17-24	25-32
INPUT		OUTPUT	
1-8	9-16	1-8	9-16
INPUT		OUTPUT	

#### 6.1.2 SL-AD3232-110

Connect your audio cables according to the following table:

17-24	25-32	17-24	25-32
INPUT		OUTPUT	
1-8	9-16	1-8	9-16
INPUT		OUTPUT	

#### 6.1.3 SL-AD1616-110

Connect your audio cables according to the following table:

1-8	9-16	1-8	9-16
INPUT		OUTPUT	

#### 6.1.4 SL-AD0808-110

Connect your audio cables according to the following table:

1-8	1-8
INPUT	OUTPUT

### 6.1.5 SL-AD1602-110

Connect your audio cables according to the following table:

1-2	1-8	9-16
OUTPUT(*)	INPUT	INPUT

(\*) Note the following pinout for the OUTPUT of the SL-AD1602-110(-CP):

Channel #	DB25 Pin #		
	Hot (+)	Cold (-)	GND
Output 1	24	12	25
Output 2	10	23	11

### 6.1.6 Unbalanced audio signals

If you want to use the Sublime audio router with unbalanced audio signals you connect these signals according to the following table:

VikinX device	Unbalanced signal connection
'+'	Audio
'-'	Shield
'GND'	Shield

## 6.2 75-Ohm unbalanced routers

The Sublime 75-Ohm unbalanced AES/EBU routers offer standard 75Ohms BNC connectors for audio in- and outputs. All inputs are terminated with 75Ohms..

## 6.3 Input extension

This chapter is only applicable for SL-AD1602 (16x2) routers.

Please refer to Chapter 3.2.2 regarding input offset.

### 6.3.1 SL-AD1602-110 routers

SL-AD1602-110 allows input extension up to 128x2. Please connect the routers as shown below. An extension router is used to collect the signal from several units.

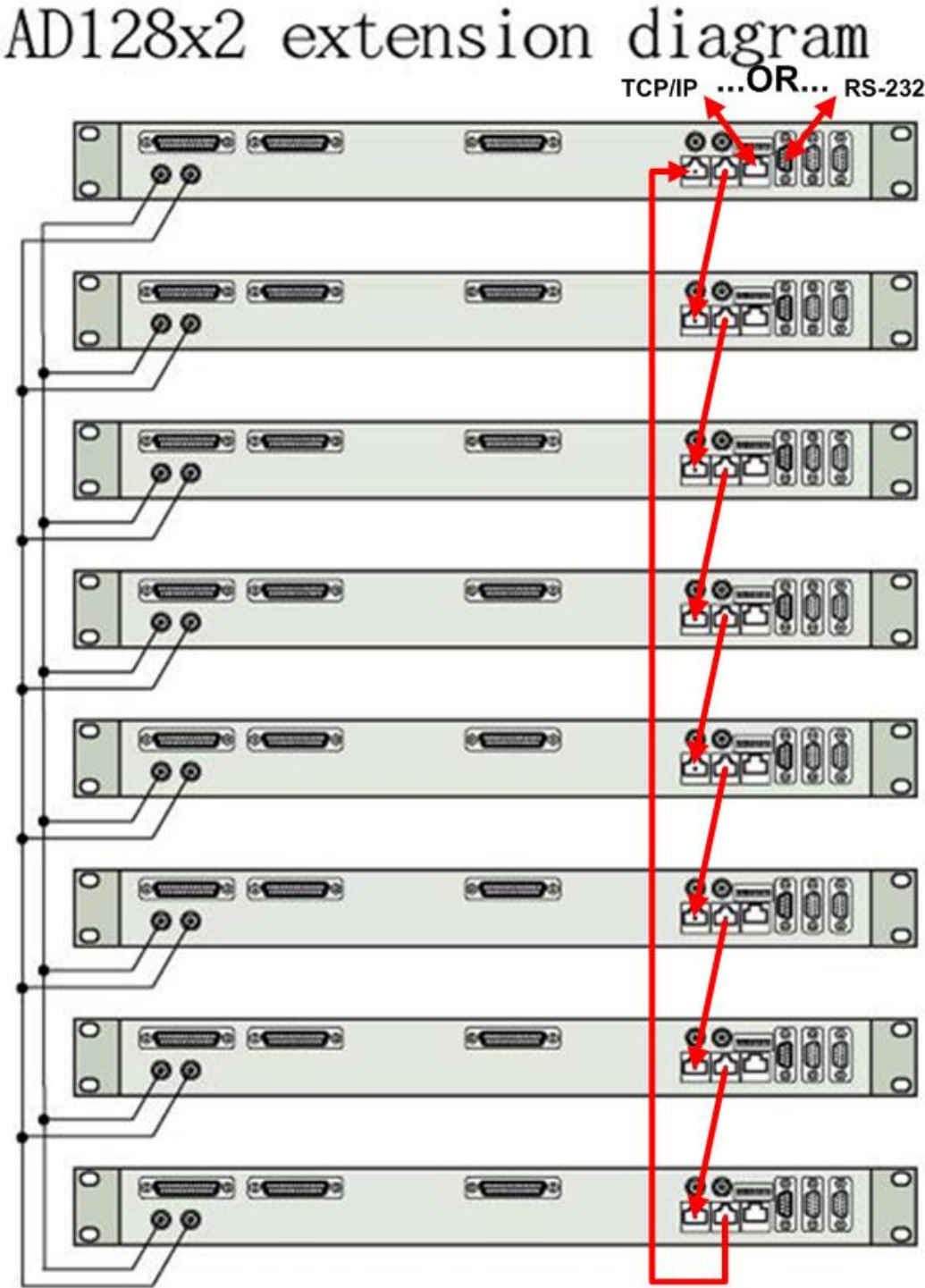

Figure 6: SL-AD12802-110 wiring diagram.



### 6.3.2 SL-AD1602-75 routers

SL-AD1602-75 allows input extension up to 64x2. An extension router is used to collect the signal from several units. The labels on the rear connectors in question are shown below, for the purpose of pre-wiring.

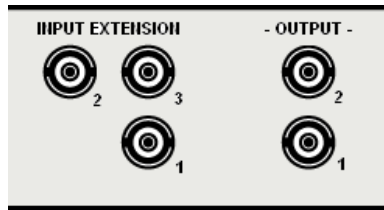

Figure 7: Input extension connectors.

Please connect the routers as shown below.

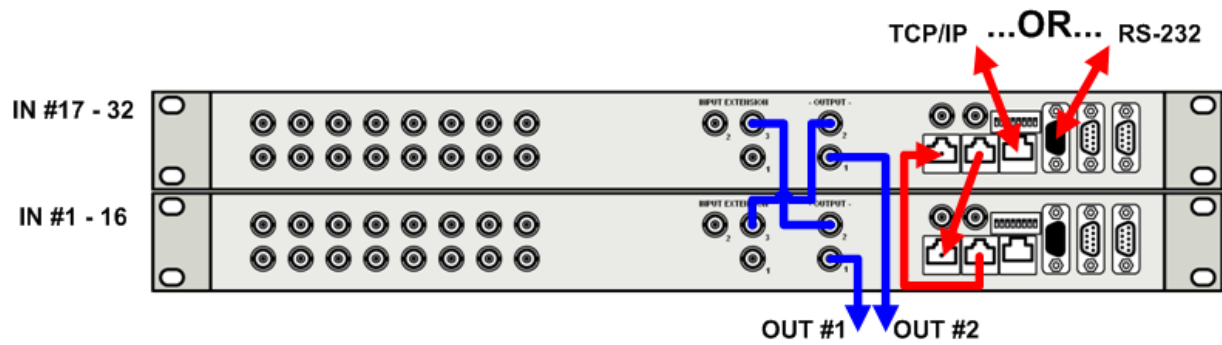

Figure 8: SL-AD3202-75 wiring diagram.

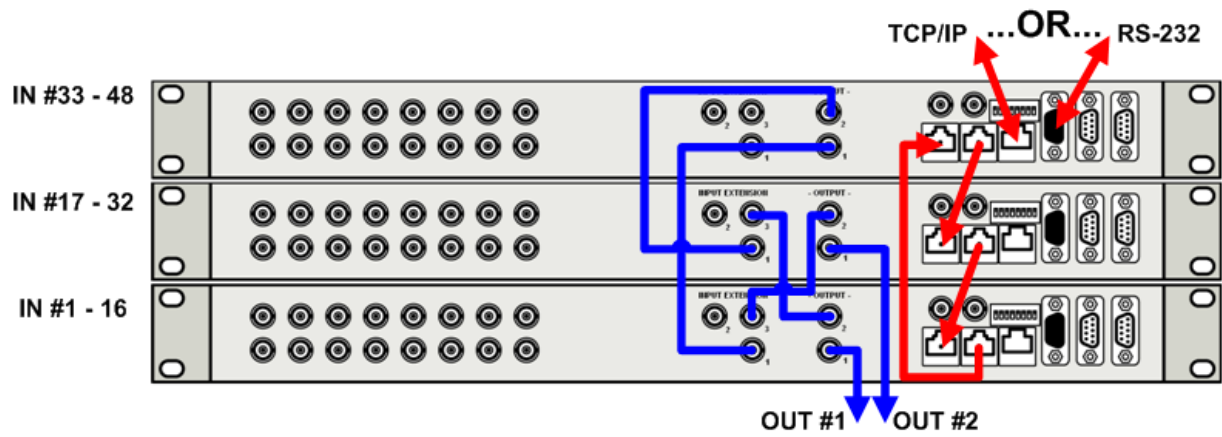

Figure 9: SL-AD4802-75 wiring diagram.

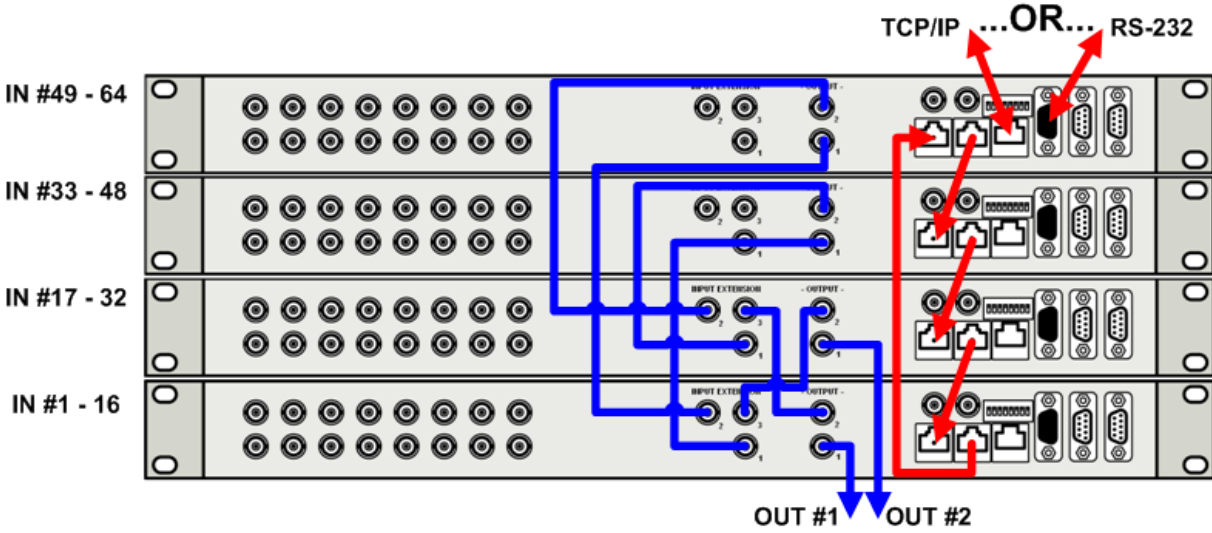

Figure 10: SL-AD6402-75 wiring diagram.

## 7 Control Panel operation

This chapter is only applicable for routers with the optional local control panel.

All local control panels are completely configurable with the System Configurator, which is downloadable from the Support pages at <http://www.nevion.com/>

All local control panels are given a default configuration, which includes the buttons “A/V Toggle”, “Panel Enable”, “Take on/off” and “Take”. In addition input and output buttons are preconfigured.

Remember to re-program the local control panel on 16x2 routers with input offset >0.

If input offset (ref. Chapter 3.2.2) is >0, ALL Input buttons on that router must be re-programmed in order to operate on the associated router inputs.

### 7.1 Button description

#### 7.1.1 A/V Toggle

The A/V Toggle button enables/disables audio and video on a specified address. The address can either be read from the dip switches, or be fixed. The button toggles between three states.

If the button is pressed for more than 1 second, it will go into a fourth state where both audio and video are disabled.

In this state the button will be dimmed. If the button is pressed for more than 1 second again, it will enable both audio and video if present.

Button Color	Video Enabled	Audio Enabled
Yellow	Yes	Yes
Green	Yes	No
Red	No	Yes
Dimmed	No	No

If neither audio nor video is present, it will be marked as disabled and the toggle state will not be used.

Toggle status changes will be stored in flash and used when the panel is powered up later.

**The following information is only valid for Sublime FW version 2.5.3 and older:**

If neither audio nor video is present, it will be marked as disabled and the toggle state will not be used.

When a panel is powered on it will search for connected routers. If no routers are found the A/V Toggle button will be disabled (no light in the button).

*This can happen if the panel is powered up before any routers are connected or if there is something wrong with the cabling.*

To re-enable the A/V Toggle do the following:

1. Activate the *Panel Enable* button (Green light).
2. Push & Hold the A/V Toggle-button for 2 seconds.

The A/V Toggle-button should now be activated and the light turned on.

### 7.1.2 Panel Enable

The panel always starts in disabled mode. In this state the button will be red and all the other buttons will be disabled. When pressing the button the panel will be enabled and the color will change to green. A status request will also be sent to get information on active levels.

### 7.1.3 Take on/off

The Take on/off button enables or disables the Take button. If no take button is defined, Take on/off is always off. On first start-up the take button is enabled. Later it will read the last status from the flash memory.

### 7.1.4 Take

The Take buttons LED is normally off. If the Take on/off button is set to “on”, no commands will be sent from the panel until the Take button is pressed. The last selected buttons and the take button will blink, until the Take button is pressed and the command is sent from the panel.

### 7.1.5 Output

An Output button is used for selecting an output. Selecting an output activates it, so that it is switched to the next input that is selected.

### 7.1.6 Input

An Input button switches the active output to the selected input. If the Take button is enabled, the switch will not be executed until the Take button is pressed.

When switching using the Input button, all enabled audio- and video-levels will be switched from the selected input to the active output.

The Input button can also be used to select the active output. This is useful on single bus panels. It requires that a *Panel Enable* button is present. When the panel is enabled, press the *Panel Enable* button and hold it while selecting the active output by pressing an *Input* button. Then release the *Panel Enable* button. The panel will now be disabled. Press the *Panel Enable* button again to enable it.

### 7.1.7 XY

An Input to Output (XY) button switches a preset input to a preset output on all enabled audio- and video-levels. If the Take button is enabled, the switch will not be executed until the Take button is pressed.

The maximum router size(s) that may be controlled without Multicon is formed by IN#1-128 and OUT#1-64 (router size: 128x64). This size limitation is regardless of the number of routers the control panel(s) is/are controlling.

See also the limitations 1 and 2 in Chapter 5.2.1.

### 7.1.8 Salvo

A Salvo button switches a sequence of X-points. This is done even if the specified audio- or video-level is disabled.

Salvo limitations on Sublime routers with local control panels:

1 level (audio + video) up to 128x128;  
20 salvos of max 64 X-points each.

Salvo limitations on Sublime stand-alone control panels:

4 levels (audio + video) up to 128x128;

20 salvos of max 64 X-points each.
------------------------------------

**7.1.9 Lock**

A Lock Toggle button toggles the lock-status on the active output on all enabled audio- and video-levels. If the active output on any of the enabled levels is locked before pressing the button, they will be unlocked. If not the active output on all enabled levels will be locked. A locked output can't be switched.

**7.1.10 Protect**

A Protect Toggle button toggles the protect-status on the active output on all enabled audio- and video-levels. If the active output on any of the enabled levels is protected before pressing the button, it will become unprotected. If not, the active output on all enabled levels will be protected. A protected output can't be switched by anyone else but the user that protected it.

## **General environmental requirements for Nevion equipment**

1. The equipment will meet the guaranteed performance specification under the following environmental conditions:
  - Operating room temperature range: 0°C to 45°C
  - Operating relative humidity range: <95% (non-condensing)
  
2. The equipment will operate without damage under the following environmental conditions:
  - Temperature range: -10°C to 55°C
  - Relative humidity range: <95% (non-condensing)

## **Product Warranty**

The warranty terms and conditions for the product(s) covered by this manual follow the General Sales Conditions by Nevion, which are available on the company web site:

[www.nevion.com](http://www.nevion.com)

## **Important notes regarding Software in the VikinX Sublime router family range**

This product utilizes software components that are licensed with open source licenses. The source code for these components and our modifications are available from: <http://labs.nevion.com/open-source/>

OpenTCP includes software developed by Viola systems (<http://www.violasystems.com/>).



## Appendix A Materials declaration and recycling information

### A.1 Materials declaration

For product sold into China after 1st March 2007, we comply with the “Administrative Measure on the Control of Pollution by Electronic Information Products”. In the first stage of this legislation, content of six hazardous materials has to be declared. The table below shows the required information.

組成名稱 Part Name	Toxic or hazardous substances and elements					
	鉛 Lead (Pb)	汞 Mercury (Hg)	鎘 Cadmium (Cd)	六价铬 Hexavalent Chromium (Cr(VI))	多溴联苯 Polybrominated biphenyls (PBB)	多溴二苯醚 Polybrominated diphenyl ethers (PBDE)
All products referred to in Chapter 1.1	○	○	○	○	○	○
SL-PWR-40 / SL-PWR-90	○	○	○	○	○	○
O: Indicates that this toxic or hazardous substance contained in all of the homogeneous materials for this part is below the limit requirement in SJ/T11363-2006.						
X: Indicates that this toxic or hazardous substance contained in at least one of the homogeneous materials used for this part is above the limit requirement in SJ/T11363-2006.						

Parts without any of the above mentioned hazardous substances are indicated by the product marking:



### A.2 Recycling information

Nevion provides assistance to customers and recyclers through our web site <http://www.nevion.com/>. Please contact Nevion’s Customer Support for assistance with recycling if this site does not show the information you require.

Where it is not possible to return the product to Nevion or its agents for recycling, the following general information may be of assistance:

- Before attempting disassembly, ensure the product is completely disconnected from power and signal connections.
- All major parts are marked or labeled to show their material content.
- Depending on the date of manufacture, this product may contain lead in solder.
- Some circuit boards may contain battery-backed memory devices.

## Appendix B Additional Protocol information

### B.1 Leitch Pass-Through protocol

This protocol is available in Sublime firmware 2.4.0 and later.

The Sublime implementation of Leitch Pass-Through supports all commands described in "Leitch Routing Switchers Serial Protocol Reference, Edition E".

In the command "Alarms Status Request", a bit-field is used for reporting active alarms. In Sublime, the bit-field is used as in the table below.

Bit	Description	Reported from firmware version
0	Power A failed	2.4.0
1	Power B failed	2.4.0
2	Positive power too low	2.4.0
3	Negative power too high	2.4.0
4	Client TCP/IP connection failed	2.4.0
5	No valid product key	2.4.0
6	SFP error	2.4.0
7	EXT IN not locked	2.5.4
8	EXT IN CRC error counting	2.5.4

### B.2 Grass Valley Native protocol

This protocol is available in Sublime firmware 2.5.4 and later.

Sublime does not support all commands available in this protocol. The supported commands are described in the table below.

Command	Parameter	Comments												
BK - Background Activities	E - Echo	BK,E and BK,E,ON and BK,E,OFF are all accepted and will be responded with ER,00,BK.												
	R - Protocol Processor Software Revision #	Will be responded with KB,R,<firmware version>.												
TJ - Request Take Index With Level Bitmap		Each command supports only one X-point.												
TI - Request Take Index With Level Index		The optional levelIndex is not supported. The command can only be used to switch all levels.												
QH - Query alarm status	AC - Query active alarm status	Sublime has defined the alarms defined in the table below. All active alarms will be responded on this request.												
		<table border="1"> <thead> <tr> <th>Alarm ID</th> <th>Alarm Name</th> <th>Alarm Parameter</th> </tr> </thead> <tbody> <tr> <td>0x0105</td> <td>Power-supply</td> <td>01 - Power A failed 02 - Power B failed</td> </tr> <tr> <td>0x010A</td> <td>Positive power too low</td> <td>Always 00</td> </tr> <tr> <td>0x010B</td> <td>Negative power to high</td> <td>Always 00</td> </tr> </tbody> </table>	Alarm ID	Alarm Name	Alarm Parameter	0x0105	Power-supply	01 - Power A failed 02 - Power B failed	0x010A	Positive power too low	Always 00	0x010B	Negative power to high	Always 00
		Alarm ID	Alarm Name	Alarm Parameter										
		0x0105	Power-supply	01 - Power A failed 02 - Power B failed										
0x010A	Positive power too low	Always 00												
0x010B	Negative power to high	Always 00												

		0x010C	Client TCP/IP connection failed	Always 00
		0x010D	No valid product key	Always 00
		0x010E	SFP error	Always 00
		0x010F	EXT IN not locked	Always 00
		0x0110	EXT IN CRC error counting	Always 00
QN - Query Names	L - Level			
	IS - Sources with source indexes	On SL-D32P+ the next available source will be labeled "DISCONNECT" and used to disconnect destinations.		
	ID - Destinations with destination indexes			

# EC Declaration of Conformity



<b>MANUFACTURER</b>	Nevion Europe AS P.O. Box 1020, 3204 Sandefjord, Norway	
<b>AUTHORIZED REPRESENTATIVE (Established within the EEA)</b>	Not applicable	
<b>MODEL NUMBER(S)</b>	SL-AD0808-75 SL-AD0808-75-CP SL-AD0808-110 SL-AD0808-110-CP SL-AD1616-75 SL-AD1616-75-CP SL-AD1616-110 SL-AD1616-110-CP SL-AD1602-75 SL-AD1602-75-CP SL-AD1602-110 SL-AD1602-110-CP SL-AD3232-110 SL-AD3232-110-CP SL-AD3232-75 SL-AD3232-75-CP SL-AD6464-110 SL-AD6464-110-CP	SL-AD6464-75 SL-AD6464-75-CP SL-16XY-CP SL-8XY-CP SL-16D-CP SL-32S-CP SL-8XY-CP SL-16D-CP SL-32S-CP SL-32S-CP-GPI SL-16S-CP SL-16S-CP-GPI SL-8S-CP SL-8S-CP-GPI SL-32XY-CP SL-64S-CP SL-64S-CP-GPI SL-64XY-CP
<b>DESCRIPTION</b>	AES/EBU Digital Audio Routers in the VikinX Sublime series	
<b>DIRECTIVES this equipment complies with</b>	Low voltage (EU Directive 2006/95/EC) EMC (EU Directive 2004/108/EC) RoHS (EU Directive 2002/95/EC) China RoHS <sup>3</sup> WEEE (EU Directive 2002/96/EC) REACH	
<b>HARMONISED STANDARDS applied in order to verify compliance with Directive(s)</b>	EN 55103-1:1996 EN 55103-2:1996 EN 55103-1:2010 EN 55103-2:2010	
<b>TEST REPORTS ISSUED BY</b>	<b>Notified/Competent Body</b>	<b>Report no:</b>
	Nemko	E08444.00
	Nemko	E08445.00
	Nemko	E08443.01
	Central Research Laboratory	09500570
<b>TECHNICAL CONSTRUCTION FILE NO</b>	Not applicable	
<b>YEAR WHICH THE CE-MARK WAS AFFIXED</b>	2008 2008 2011 2010	

<sup>3</sup> Administration on the Control of Pollution Caused by Electronic Information Products

**TEST AUTHORIZED SIGNATORY**

**MANUFACTURER**

**AUTHORIZED REPRESENTATIVE**  
(Established within EEA)

**Date of Issue**

2011-04-07

**Place of Issue**

Sandefjord, Norway



NEVION EUROPE AS  
O.nr. 976 584 201 MVA

Not applicable

**Name** Thomas Øhrbom

**Position** VP of Quality, Nevion  
(authorized signature)

**Nevion Europe AS**

P.O. Box 1020, 3204 Sandefjord, Norway – Tel: +47 33 48 99 99 – Fax: +47 33 48 99 98  
[www.nevion.com](http://www.nevion.com)