

# Analog Video and Audio Embedder to Fiber

## Nevion AS

P.O. Box 1020  
N-3204 Sandefjord, Norway

Phone: +47 33 48 99 99

Fax: +47 33 48 99 98

Email: [support@nevision.com](mailto:support@nevision.com)

[www.nevision.com](http://www.nevision.com)

Support Phone: +47 90 60 99 99

### Revision history

Current revision of this document is the uppermost in the table below.

Rev.	Repl.	Date	Sign	Change description
2	1	2009-03-20	NBS	Total update, following from replacing discontinued AAV-MUX with new AAV-SD-XMUX.
1	0	2007-10-15	AS	New front page.
0	-	2006-02-07	MDH	First release of product.

## Contents

1 Product overview .....	5
1.1 AVA-MUX-C2 .....	5
1.2 AAV-SD-XMUX(-T).....	5
1.3 ADC-SDI .....	5
1.4 Signal flow .....	6
2 Specifications .....	7
2.1 Measurement conditions.....	7
2.2 General .....	7
2.3 Processing.....	7
2.3.1 SD latencies AAV-SD-XMUX.....	7
2.3.2 SD latencies ADC-SDI.....	7
2.4 Inputs .....	7
2.4.1 Analog Video input .....	7
2.4.2 Analog audio inputs .....	8
2.4.3 Digital Audio Inputs.....	8
2.4.4 Data inputs .....	8
2.5 Outputs.....	8
2.5.1 SDI output .....	8
2.5.2 Optical output .....	9
2.5.3 Digital Audio outputs.....	9
2.5.4 Data outputs .....	9
2.5.5 GPI outputs .....	9
2.6 Connector module .....	10
2.6.1 AVA-MUX-C2 .....	10
2.6.2 Mounting the connector module.....	10
3 Configuration .....	11
3.1 Video (ADC-SDI) .....	11
3.1.1 DIP switches.....	11
3.1.2 Monitoring and control of ADC-SDI with Gyda .....	12
3.2 Audio (AAV-SD-XMUX) .....	12
3.2.1 DIP switch Configuration .....	13
3.2.2 GYDA Control.....	16
3.2.3 Data transmission.....	17
4 Connections.....	19
4.1 Audio connections DB25 .....	19
4.2 GPI/Data connections 8P8C Jack.....	20
5 Operation.....	21
5.1 ADC-SDI LEDs.....	21
5.2 AAV-SD-XMUX LEDs.....	21
5.3 GPI alarms .....	22
6 Laser safety precautions.....	23
General environmental requirements for Nevia equipment.....	24
Product Warranty.....	25
Appendix A Materials declaration and recycling information.....	26
A.1 Materials declaration .....	26
A.2 Recycling information .....	26
EC Declaration of Conformity .....	27

---

EC Declaration of Conformity ..... 28

# 1 Product overview

The AVA-MUX unit actually consists of three modules:

- The AVA-MUX-C2 connector backplane.
- The AAV-SD-XMUX(-T) AES and Analog Audio Embedder (with optical transmitter).
- The ADC-SDI composite decoder to SDI converter.

## 1.1 AVA-MUX-C2

The AVA-MUX backplane has all the necessary connections for the audio and video signals. It also has all of the inter-connections between the two processing cards. There are passive loop-through connectors for the analog video inputs. Termination of the analog video inputs is also configurable on the back panel.

## 1.2 AAV-SD-XMUX(-T)

The AAV-SD-XMUX is a highly integrated audio embedding module in the Flashlink range, offering simultaneous embedding and de-embedding of audio from an SD serial video signal.

In the AVA-MUX application, the AAV-SD-XMUX can:

- De-embed and embed all groups of audio.
- Copy or move audio groups without additional delay.
- De-embed 2 AES3 digital audio and non-audio signals.
- Embed 2 AES3 digital audio and non-audio signals.
- Embed 4 analog audio signals.
- Apply sample rate converters when needed on the AES3 inputs.
- Apply extra audio delay.
- Swap stereo channels.
- Make mono or sum from stereo signals.
- Have optical laser output.
- Transport asynchronous serial data.
- Generate video and audio signals.
- De-glitch correctly synchronized switched video.

The card has a serial digital video input and a serial digital video output. There is an optional optical output with a choice of lasers that may be applied in point to point and CWDM configurations.

## 1.3 ADC-SDI

The ADC-SDI is a high-quality 10-bit composite to digital video converter. The converter has two inputs which it can use as two CVBS or one S-video inputs. The input mode can either be locked or the card will scan the inputs and all formats until it finds a valid signal. The ADC-SDI can be configured with switches on the unit, or via the GYDA control interface. The ADC-SDI can generate a white pulse to mark field one of an 8-field-PAL/4-field-NTSC signal. An intelligent composite encoder/ digital to analog converter (like the DAC-SDI) will encode to the correct field (8-field-PAL/4-field-NTSC). This will reduce artifacts due to composite decoding and re-encoding.

## 1.4 Signal flow

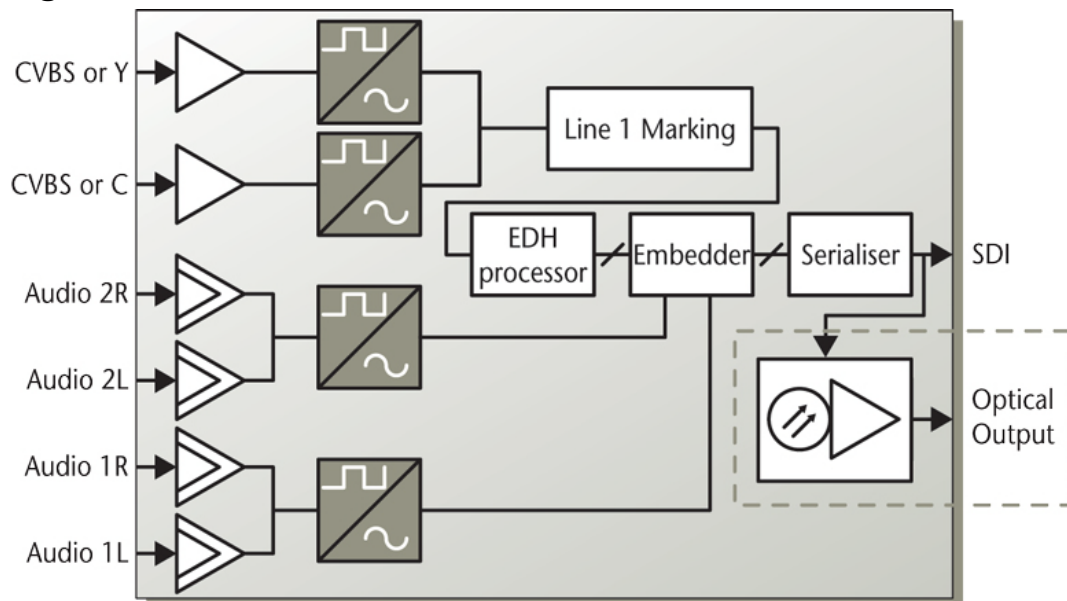

Figure 1: AVA-MUX signal flow

The analog video input signal type is identified. The synchronization information in the analog signal is detected. The analog signal is digitized to a 10-bit parallel signal. An FPGA adds EDH information and Field 1 marking. The signal is serialized and goes to the embedder card. The video is de-serialized and passed to the embedding processor which inserts the digital audio. The video signal is then re-serialized and sent to the electrical and optical outputs.

The audio embedder module has two main processing blocks. One processes the video stream and the packet data, the other processes the audio. The packet processing core forms a group router which can route embedded audio between groups without any extra delay.

The AAV-SD-XMUX audio core is an AES3 stereo audio router. The received embedded audio and the audio inputs are the sources in the router. The embedded output groups and AES3 outputs are the destinations. This feature may also be used to perform stereo channel swapping.

Four stereo delay lines are also available in the router with a total combined delay of 1.25s.

Audio processing is possible within each stereo output. The channels may be changed allowing L/R swapping, mono assignment, summing, MS conversion and phase reversal of one of the signals.

There are two embedding modes:

- Non-SRC mode: The AES3 input signals are embedded transparently.
- Automatic mode: The module will use sample rate converters when necessary.

Data signals such as Dolby E will always be embedded transparently without using the sample rate converters.

All embedding and de-embedding is performed with synchronous 48 kHz audio.

## 2 Specifications

### 2.1 Measurement conditions

Audio Sampling rate:	48 kHz.
Ambient temperature:	25°C.
Measurement bandwidth:	20 Hz-20 kHz.
Detector:	RMS.
Input overload level (0 dBFS):	+18 dBu.

### 2.2 General

Power, AAV-SD-XMUX:	+5V DC / 0.7A, 3.5W +/-15V DC / 0.017A, 0.5W.
Power, ADC-SDI:	+5V DC / 0.44A, 2.2W -15V DC / 0.046A, 0.7W.
Control:	DIP switches, Gyda system controller.
Monitoring:	Front panel LED's and GYDA system controller.
EDH processing:	Full. Received flags are updated; new CRCs are calculated.
Embedding level:	SMPTE S272M C – Synchronous audio at 48 kHz and extended data packets. (24 bit optional).
Embedded audio word length:	Configurable 20 or 24 bits.
Video processing word length:	10 bits.
Total Audio Delay:	<i>To be measured.</i>
Total Video Delay:	<i>To be measured.</i>

### 2.3 Processing

Video latency is variable due to the de-glitcher but the values below apply when the video signal is first applied. Other latency values are maximum values.

#### 2.3.1 SD latencies AAV-SD-XMUX

Video:	$des+4+350+256+2+ser$ video samples = 45.3us.
Audio embedding:	$AES+2+1+16$ audio samples= $20/48000 = 417us$ .
Audio de-embedding:	$4+16+1$ audio samples = $21/48000 = 438us$ .
Embedding data GPI mode:	$8+4+32$ 96kHz samples = $44/96000 = 458us$ .
Embedding data UART mode:	$32+128+17+16$ 96kHz samples = $193/96000 = 2.01ms$ .
De-embedding data GPI mode:	$8+32+8$ 96kHz samples = $44/96000 = 458us$ .
De-embedding UART mode:	$8+32+8$ 96kHz samples = $48/96000 = 458us$ .

#### 2.3.2 SD latencies ADC-SDI

Video:	2 video lines.
--------	----------------

### 2.4 Inputs

#### 2.4.1 Analog Video input

Format:	PAL, NTSC, S-Video.
Video frame rate:	50 Hz or 60 Hz.
Impedance:	75 ohms.
Return loss:	>40dB up to 5.75 MHz.
Signal level:	1V.
Connectors:	BNC.
Termination configuration:	DIP switches on backplane.

## 2.4.2 Analog audio inputs

Number of inputs:	4.
Sampling frequency:	48 kHz.
Differential input impedance:	24 kohm.
Common mode input impedance:	50 kohm.
Connector:	DB-25F (Female with UNC threads).
Maximum signal level (0 dBFS):	+12, +13.5, +15, +16.7, +18, +20, +21 or +24dBu.
Level precision:	+/- 0.1dB where Zsource < 40 ohm.
Common mode voltage tolerance:	+/- 30V – (Maximum peak signal level).
Frequency response:	20 Hz – 20 kHz 0.1 dB.
Pass-band ripple:	+/- 0.005 dB.
Stop band attenuation:	80 dB.
Dynamic range <sup>1</sup> :	Min. 103 dB (A), typical 107 dB (A).
THD+N @ -1 dBFS:	Max. -90 dB, typical -96 dB.
Intermodulation distortion <sup>2</sup> :	Max. -90 dB, typical -95 dB.
Crosstalk:	Max. -90 dB, typical -99 dB.
CMRR (20 Hz – 15 kHz):	Max. 70 dB @ 15 kHz, typical -90 dB @ low frequencies.

## 2.4.3 Digital Audio Inputs

Number of AES3 inputs:	2.
Audio data rate:	30 kHz to 200 kHz, converted to 48 kHz if not 48 kHz and isochronous to the video input signal.
Input impedance:	110 ohms transformer balanced.
Connector (C1 backplanes):	DB-25F (Female with UNC threads).
Embedded audio word length:	20 or 24 bits.
Embedded audio Channel Status:	As received when isochronous, otherwise fixed.
Sample rate converter dynamic range:	139 dB (A) @ 1kHz.

## 2.4.4 Data inputs

RS422:	1.
Connector:	8P8C Modular jack.
UART mode:	
Baud rates:	9600 to 115200.
Data length:	7 or 8 bits.
Parity:	None, odd or even.
Stop bits:	1, 1.5 or 2 bits.
GPI mode:	
Raw data sampling frequency:	93750 Hz.

## 2.5 Outputs

### 2.5.1 SDI output

Video Data rate:	270Mbps.
Number of SDI outputs:	1.
Connector:	BNC.
Impedance:	75 ohms.
Return loss:	> 15dB @270MHz.
Signal level:	nominal. 800mV.
Rise/fall time:	typically 650ps.

<sup>1</sup> |THD+N of -60 dBFS 1 kHz signal| + 60.

<sup>2</sup> Signal at -12 dBFS, SMPTE 4:1 60 Hz + 7 kHz.



### 2.5.2 Optical output

Transmission circuit fiber:	Single Mode.
Optical wavelength (ver. 13T):	1310nm $\pm$ 40nm.
Optical power:	-7.5 dBm.
Optical power (option):	0 dBm.
Optical wavelength (ver. 15T):	1550nm $\pm$ 40nm.
Optical power:	0 dBm.
Optical wavelength (ver. C1xxx):	1270, 1290, 1310, 1330, 1350, 1370, 1390, 1410, 1470, 1490, 1510, 1530, 1550, 1570, 1590, 1610nm $\pm$ 6nm; as per ITU-T G.694.2.
Optical power:	0 dBm
Jitter (UI=unit interval):	Max. 0.135 UI
Return loss:	Typ. > 40 dB
Maximum reflected power:	4%
Connector:	SC/UPC

### 2.5.3 Digital Audio outputs

Number of AES3 outputs:	2.
Audio data rate:	48 kHz.
Impedance (C1 backplanes):	110 ohm transformer balanced.
Connector (C1 backplanes):	DB-25F (Female with UNC threads).

### 2.5.4 Data outputs

Number of RS485 outputs	1.
Connector	8P8C Modular jack.

### 2.5.5 GPI outputs

Signals:	Power status good, no video input lock, laser failure.
Connector:	8P8C Modular jack.
Signal type:	Open drain transistor with free-wheel diode.
Maximum voltage:	100 V.
Maximum current:	150 mA.

## 2.6 Connector module

### 2.6.1 AVA-MUX-C2

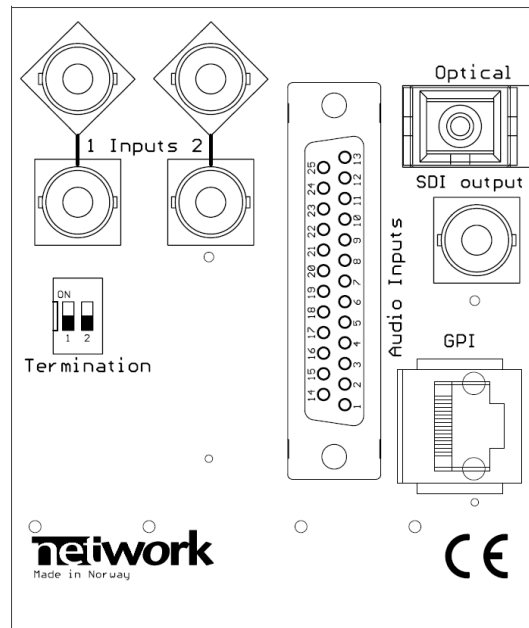

Figure 2: AVA-MUX-C2

### 2.6.2 Mounting the connector module

The details of how the connector modules are mounted can be found in the user manual for the sub-rack frame: FR-2RU-10-2.

This manual is available from our web site: <http://www.nevion.com/>

## 3 Configuration

### 3.1 Video (ADC-SDI)

#### 3.1.1 DIP switches

The configuration of the card can always be changed from the GYDA system controller but may also be configured with DIP switches. Most users will set all switches OFF except switches 1 and 10.

##### 3.1.1.1 Manual mode

DIP switch 1 should be in the ON position if the card is to be controlled with the other DIP switches. If the switch is OFF then the card starts with the stored configuration and the other switches are ignored. GYDA is always able to re-configure the card but the new configuration will only be remembered if switch 1 is OFF.

##### 3.1.1.2 Video input mode

DIP switches 2 and 3 configure the input channel selection modes as shown in the table.

Switch		Output Video Mode
3	2	
0	0	Auto detect. The first valid detected signal is used.
0	1	CVBS on input 1.
1	0	CVBS on input 2.
1	1	YC or (S-Video, SVHS) on inputs 1 and 2.

##### 3.1.1.3 EDH packet disable

DIP switch 4 should be in the ON position if the SDI signal must not contain an EDH packet.

##### 3.1.1.4 Field 1 marking disable

DIP switch 5 should be switched ON if the SDI signal must not have a field 1 marker on line 7.

##### 3.1.1.5 Decoder filter selection

DIP switch 6 and 7 are used to select the decoder filter used, as shown in the following table. The ADC-SDI has two adaptive filters, a comb filter and a low pass/ notch filter set.

Switch		Decoder filter
7	6	
0	0	Default. Adaptive 3-line comb filter selection. NTSC adaptive comb with filter coefficients ( $\frac{1}{4}$ , $\frac{1}{2}$ , $\frac{1}{4}$ ), PAL adaptive comb with filter coefficients ( $\frac{1}{2}$ , 0, $\frac{1}{2}$ )
0	1	Adaptive 3-line comb filter selection with optional filter coefficients. NTSC adaptive comb with filter coefficients ( $\frac{1}{2}$ , 0, $\frac{1}{2}$ ), PAL adaptive comb with filter coefficients ( $\frac{1}{4}$ , $\frac{1}{2}$ , $\frac{1}{4}$ )
1	0	Fixed 2-line comb filter.
1	1	Luminance filtered with chroma trap notch. Chroma low pass filtered.

##### 3.1.1.6 Restore factory settings

DIP switch 8 should be used if the card is to be reset to the factory configuration. This will also reset the delay parameters to zero. The card is reset when the card is powered up with this switch set ON. DIP switch 8 should be set back to the OFF position and the card should then be reset.

The reset button at the front of the card may be used instead of removing the card or switching the power supplies on and off.

### 3.1.1.7 Reserved switches

DIP switch 9 is reserved for future use and should be in the OFF position. DIP switch 10 chooses programming or run mode and should always be in the ON position.

### 3.1.2 Monitoring and control of ADC-SDI with Gyda

The Gyda controller card receives information about the configuration and the operating status of the card. The displayed information includes:

- Slot label (set on configuration page)
- Firmware and FPGA versions
- Input video mode
- Input status
- EDH generation status
- Field 1 marking status
- Filter mode
- Alarms

The configuration page allows control of the following configuration parameters

- Input configuration.
- Enable/ disable EDH.
- Enable/ disable Field 1 marking.
- Filter selection.
- Card label.

## 3.2 Audio (AAV-SD-XMUX)

The XMUX embedding core can be considered as an 18x14 stereo audio router and a 5x4 group router.

The group router is used to transport or shuffle groups without introducing any additional delay.

The inputs or sources in the stereo router are from the de-embedded audio groups, the AES and analog audio inputs, the delay line outputs and the two built in generators.

The stereo router outputs or destinations are the groups of embedded audio in the output video, the AES outputs and the delay line inputs.

A normal de-embedder configuration would route the de-embedded audio to the AES outputs.

A normal embedder configuration would be to route the audio inputs to the appropriate embedder group outputs.

The AAV-SD-XMUX module can do both at the same time!

Many other configurations are possible and the module may be dynamically controlled as an 18x14 audio router via the system controller, GYDA.

Full control of the module is performed with the GYDA system controller. Controls only possible with GYDA are:

- The data transmission parameters and channel selection.
- The output processing of each stereo signal (LR, RL, LL, RR, MS, Sum, ØLR, LØR).
- The delay lines delays and routing.
- Video and audio generator configuration.

### 3.2.1 DIP switch Configuration

**ATTENTION:** The switch settings are only read when the module is powered up.

#### 3.2.1.1 Routing

Full hardware control of all of the parameters in the module would require either, a complicated menu type of control interface with a display and control buttons; or an enormous number of switches. In many cases, most of the parameters will not be changed from the default settings. It was decided to control only the most used parameters with switches. This still requires the use of 24 switches.

The switches are only read if SW1.8 (DIP configuration mode) is in the on position.

There are not enough switches on the module to allow full stereo routing configurations. Groups of four channels are routed together as units, for example: AES input channels 1&2, embedded audio group 1.

##### 3.2.1.1.1 Destinations

**Table 1: Routing control switches**

SW1				SW2				SW3															
Group1			Group2			*	*	Group3			Group4			*	*	AES1&2		ADC Gain		*	*		
1	2	3	4	5	6	7	8	1	2	3	4	5	6	7	8	1	2	3	4	5	6	7	8

The switches control the routing of signals to the outputs or destinations. There are four embedded audio groups and one pair of AES outputs. The configuration assigns sources to output groups and the pair of AES outputs. This allows the same input signals to be routed to several outputs.

There is a group of three switches for each of the outputs. The combination of the three switches set the input source or disables the output e.g.

- Group 1 embedded output is controlled by switches on SW1 positions 1, 2 and 3.
- AES outputs are controlled by switches on SW3 positions 1, 2 and 3.

##### 3.2.1.1.2 Sources

There are eight possible permutations of the switches. Seven of the permutations choose the input sources. One of the settings (off, off, off) is used to disable the group embedding or set the AES outputs to silence.

**Table 2: Source switch encoding**

Switch	Output disabled	group1	group2	group3	group4	AES1&2	Stereo tone
1 or 2					on	on	on
2 or 5			on	on			on
3 or 6		on		on		on	on

3.2.1.1.3 Examples

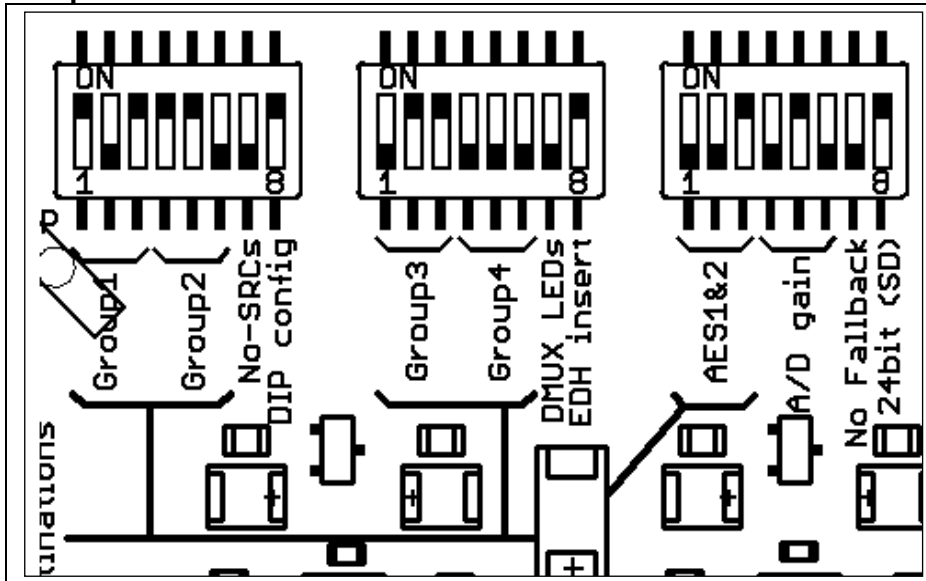

Figure 3: Example 1

The module above (Figure 3) is set to the following:

- Group1 output is embedded with signals from the ADC inputs
- Group2 output is embedded with signals from AES1&2 inputs
- Group3 output is embedded with signals from de-embedded group3
- Group4 output is not embedded
- AES1&2 outputs signals from de-embedded group1

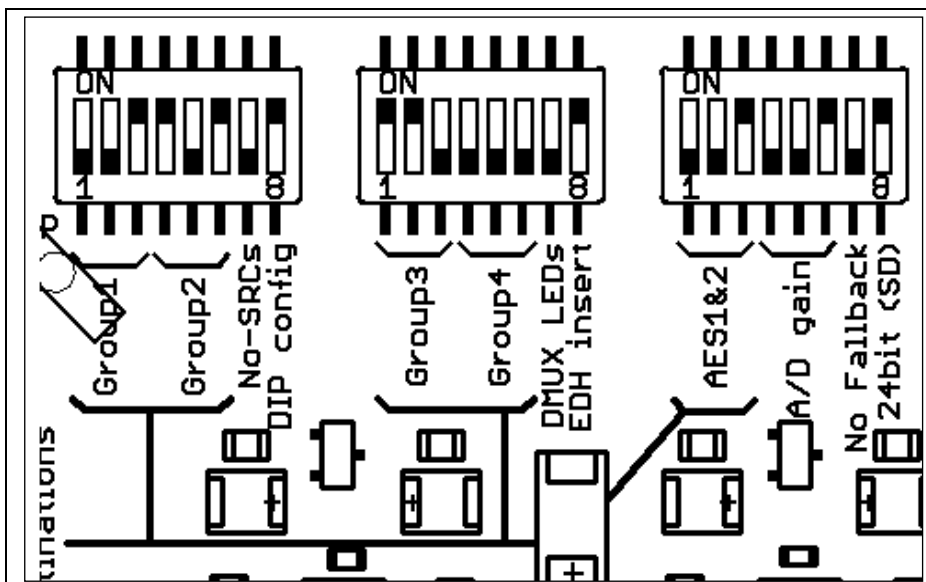

Figure 4: Example 2

The module above (Figure 4) is set to the following:

- Group1 output is embedded with signals from de-embedded group1
- Group2 output is embedded with signals from the ADC inputs
- Group3 output is embedded with signals from AES1&2 inputs

- Group4 output is not embedded
- AES1&2 outputs signals from de-embedded group1

Users familiar with binary numbers may see that numbers 1 to 4 (001 to 100) correspond to groups 1 to 4.

### 3.2.1.2 Other DIP Switches

#### 3.2.1.2.1 A/D converter gain, SW3.4+5+6

The A/D input levels may be set to one of the eight preset levels. The levels correspond to the maximum sine wave level, otherwise known as 0 dBFS.

+12, +13.5, +15, +16.7, +18, +20, +21 or +24dBu.

All four input levels are set by the DIP switches in DIP configuration mode. GYDA can set the levels for each stereo pair.

#### 3.2.1.2.2 Non-SRC mode, SW1.7

When SW1.7 and SW1.8 are on, the sample rate converters will not be used. The user must ensure that the AES input signals are locked to the video signal audio; otherwise click noises will be produced in the embedded audio signals.

#### 3.2.1.2.3 DIP Configuration, SW1.8

SW1.8 on, forces the DIP switch configuration to be used. If there is a GYDA present, the switch configuration on the module will be used but the configuration will be monitored in the GYDA controller. Control of the card parameters can not be changed with GYDA.

SW1.8 off will not use the DIP switches but will be configured from either the stored configuration in the module or from GYDA if there is GYDA present. The configuration will be stored when a GYDA configuration command is used. Therefore if a GYDA is present, the internal configuration will be overwritten by the GYDA controller.

The DIP switch settings control the routing and a couple of other important settings. Other stored settings, such as data embedding and generator settings will always be used.

#### 3.2.1.2.4 LED mode, SW2.7

The switch controls how the two audio LEDs function. If the switch is off, the LEDs show the AES receiver status. If the switch is on, the LEDs show the presence of embedded groups.

#### 3.2.1.2.5 EDH insert, SW2.8

SD video output from the module will only contain an EDH packet if SW2.8 is on.

#### 3.2.1.2.6 Fallback generator control, SW3.7

This switch is used to control the outputs when the input signals are not present.

SW3.7 **on**: The Video output will be disabled if the input signal is removed.

The AES outputs will be disabled if the source routed to that output is not present. The input presence is embedded in the embedded audio data packet so that an AES input failure on a distant card will disable an AES output which uses audio embedded by that distant card.

SW3.7 **off**: The internal video generator will be used as an input until a valid video signal is detected on one of the inputs.

The AES outputs without a source signal present will always be on but the signal will be silence.

#### 3.2.1.2.7 !20/24 bit (SD), SW3.8

SD video will contain embedded audio with a word length of 24 bits if SW3.8 is on.

SD video will contain embedded audio with a word length of 20 bits if SW3.8 is off.

HD video will always contain embedded audio with a word length of 24 bits.

### 3.2.2 GYDA Control

Full control of the stereo audio router is possible with the GYDA system controller. Direct control with SNMP is available.

The module stores its routing configuration in non-volatile memory when a GYDA command is given. This allows complex configurations to be restored after a power loss.

The configuration is stored both in the card and in GYDA. If the card must be replaced, then GYDA will restore the configuration into the new card as long as SW1.8 is off.

If GYDA fails and there is a power glitch, then the card will reboot with the stored settings.

If a GYDA system controller is present, the last configuration of the module will be only be restored by GYDA if SW1.8 is off. The intention is that SW1.8 is used to show that the card is manually configured when switched on.

#### 3.2.2.1 Audio delay lines

The unit has four stereo audio delay lines connected to the audio router. Audio to be delayed is routed to one of the delay inputs and the output of that delay is routed to the intended output. The length of each delay line is set up on the configuration page of GYDA. The maximum delay for each of the four delays is 16384 audio samples, which is about 340ms. The delay lines may be cascaded if longer delays are required.

#### 3.2.2.2 Stereo audio processing

The output of each stereo signal may be manipulated (LL, RR, LR, RL, ØLR, LØR, (L+R)/2, MS) this is controlled with the GYDA controller.

The stereo signals may be output in one of the following ways:

- LR	Left / Right	No change.
- RL	Right/ Left	Channels are swapped.
- LL	Left/ Left	Left channel is copied into the right channel.
- RR	Right/ Right	Right channel is copied into the left channel.
- ØLR	ØLeft/ Right	The left channel is phase inverted.
- LØR	Left/ ØRight	The right channel is phase inverted.
- (L+R)/2	Left + Right	The left and right channels are summed.
- MS	MS/AB	The left and right channels are converted from AB stereo to MS stereo.

The sum products ((L+R)/2 and MS) are reduced in level by 6 dB to avoid any possibility of clipping.

#### 3.2.2.3 RS422 Data port configuration

The RS422 data 8P8C Modular jack input must be configured with GYDA. The baud rate, data length, parity and stop bits must be configured if UART mode is used.

The router destination where the data is to be embedded must be set up and the source channel containing the received data that will be output on the 8P8C Modular jack must be also be configured.

See further Chapter 3.2.3.

#### 3.2.2.4 Transport and shuffling of audio groups

The AAV-SD-XMUX stereo *audio router* involves de-embedding, buffering and re-embedding which introduces a small delay relative to the video signal.

The *group router* is used to avoid this extra delay. Groups that only pass through the *group router* are re-embedded in the same video line. This avoids any extra delay and means that incompatible audio formats (asynchronous audio) may still be transported. The AAV-SD-XMUX automatically uses the *group router* whenever possible when controlled with the DIP switches.



“Shuffling” of groups is when existing embedded audio groups are re-assigned to different groups. Copying of groups is also possible i.e. Group 1 may be transported to Group 1 and duplicated to Group 2. This function also takes place in the *group router* which means that there is no extra delay.

### 3.2.2.5 Audio generator

The stereo audio generator is available in the audio router as a source. It is a high purity 1 kHz sine wave with a 250ms interruption on the left channel every 3 seconds. The audio level may be set to one of two standards. The two levels are -18 dBFS and -20 dBFS. These two levels correspond to EBU R68 and SMPTE RP 155.

### 3.2.2.6 Video generator

The video generator has several different simple signals:

- Color bar, 100% white, 75% colors, no set-up level.
- Red, Green, Blue or Black full field.

The generator may be used as a backup video source if there is no video signal present at either of the video inputs. The generator may also be switched on with GYDA. This will override video input but the generator signal will be locked to the input.

The video standard of the generator may be set with GYDA but only if there is no video input present.

### 3.2.3 Data transmission

The module can de-embed and embed asynchronous data. An AES3 audio signal is used as a carrier. Both embedded audio and normal AES3 signals may be used to carry the RS422 data. The fiber connection usually only goes one direction so any desired return path must be created by the user with another circuit. Return data may be sent over fiber via a link comprising of AV-HD-XMUX, AAV-HD-XMUX, AAV-HD-DMUX, AES, D422 or D422-MG modules.

The data input on the back panel works in one of two modes:

1. UART Mode: The data is checked for correct reception according to the configuration. The data words are packaged and sent when present.
2. Raw sampling mode: The data input is sampled at 93.75 kHz and embedded as a data stream. No checking is performed.

#### 3.2.3.1 Data latencies

The data channel has a total latency of approximately 30 $\mu$ s when using raw sampling. Normal data rates of up to 9600 may be used with raw data sampling to have a low latency. The latency is 500 $\mu$ s when using the normal data encoding due to the block structure of the AES User bits.

The configuration of the data channel is always stored in the module and used regardless of the GYDA override switch.

#### 3.2.3.2 Embedding

The AAV-SD-XMUX has a RS422 data input for the embedding of control data. The baud rate and other parameters are configured with GYDA. The factory default is 115200 baud, no parity, one stop bit.

The data channel is encoded in the User bits in an embedded audio stereo signal assigned with GYDA. The factory default is Audio channels 1&2 in Group 1.

The data is sampled asynchronously at a constant bit rate. The range of baud rates that may be transmitted is from DC to 115,200 bps. The data bytes are either encoded as packets in the transmitted data or transmitted as an asynchronous bit stream which may also be used to transmit a DC signal such as GPI.

### 3.2.3.3 De-embedding

The audio channel with the data signal to be de-embedded must be configured by GYDA as there may be several data channels available.

The AAV-SD-XMUX will automatically detect the data channel format when present and output the data on the 8P8C Modular jack connector. The output driver will only be active when data is output in UART mode. This means that the output is always active when raw data is used.

### 3.2.3.4 Limitations

1. There is one thing the user must do in order to receive embedded data. The audio source where the data is embedded must be routed to a destination in the stereo router. This is because the extraction of the data takes place on the output of the router.  
Example: Data is to be de-embedded from embedded audio channels 1&2. Route embedded audio channels 1&2 routed to output to Delay 4.
2. The normal UART mode checks the data when receiving and only embeds valid bytes. The data format must be correct. This also means that a BREAK condition of many spaces will not be detected or transmitted. Contact support if this is a requirement.

## 4 Connections

A 25 pin d-sub type connector is provided for the audio outputs. The pin configuration used is the industry standard TASCAM DA-88 type so that commercially available 'snakes' may be used.

### 4.1 Audio connections DB25

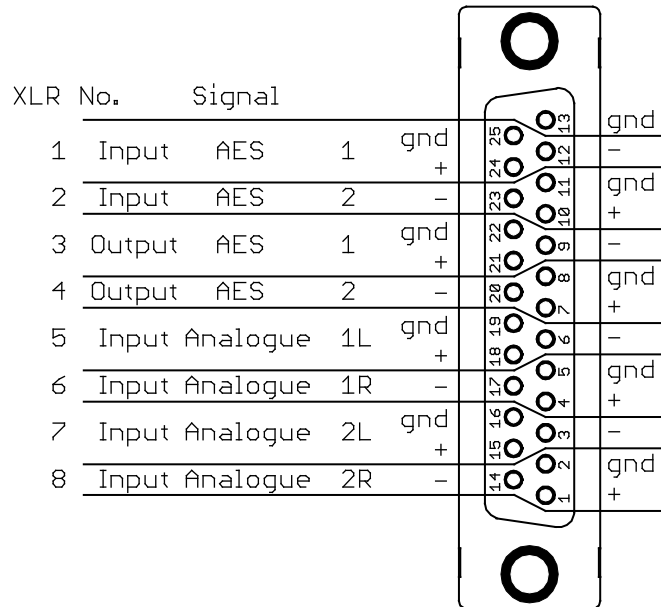
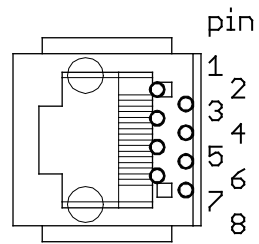

Figure 5: D-sub 25 audio connector wiring

Pin	Signal	Pin	Signal
1	2R (+)	14	2R (-)
2	2R (GND)	15	2L (+)
3	2L (-)	16	2L (GND)
4	1R (+)	17	1R (-)
5	1R (GND)	18	1L (+)
6	1L (-)	19	1L (GND)
7	AES 2 OUT (+)	20	AES 2 OUT (-)
8	AES 2 OUT (GND)	21	AES 1 OUT (+)
9	AES 1 OUT (-)	22	AES 1 OUT (GND)
10	AES 2 IN (+)	23	AES 2 IN (-)
11	AES 2 IN (GND)	24	AES 1 IN (+)
12	AES 1 IN (-)	25	AES 1 IN (GND)
13	GND		

## 4.2 GPI/Data connections 8P8C Jack



**Figure 6: Pin layout 8P8C Modular jack**

Pin number	Description
1	Power present
2	No Video signal
3	Laser failure
4	RS485/422 output +
5	RS485/422 output -
6	RS422 input +
7	RS422 input -
8	Ground

## 5 Operation

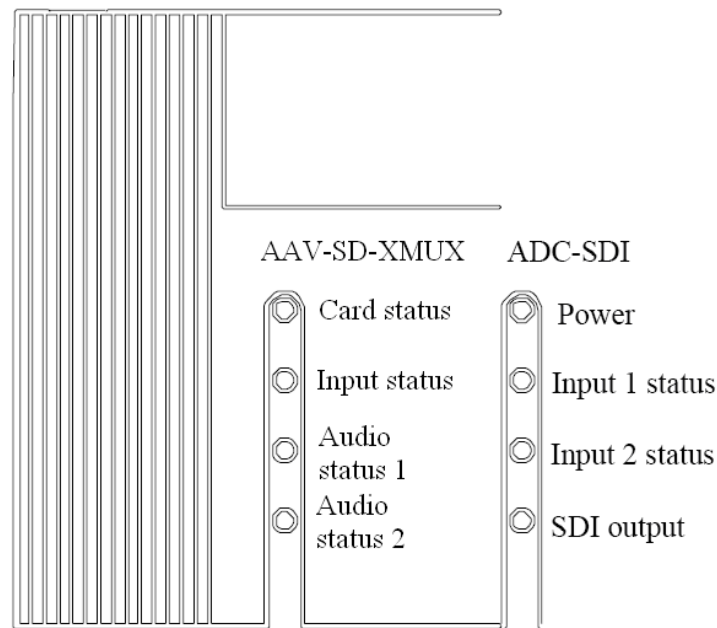

Figure 7: AVA-MUX LEDs

(Text not printed on the front panel). Each module has 4 LED's. The colors of each of the LED's have different meanings as shown in the tables below.

### 5.1 ADC-SDI LEDs

Diode \ state	Red LED	Orange LED	Green LED	No light
<b>Power</b>	Major error. Remove module	n/a	Module power is OK	Module has no power
<b>Input 1 status</b>	Video signal absent.	Signal detected but not locked	No signal	Channel inactive
<b>Input 2 status</b>	Video signal absent.	Signal detected but not locked	No signal	Channel inactive
<b>SDI output</b>	Errors detected	n/a	No errors detected	

### 5.2 AAV-SD-XMUX LEDs

AES status LEDs show information decided by DIP switch 2.7- LED mode.

'On' corresponds to the audio input mode and is the preferred setting in the AVA-MUX.

'Off' corresponds to the de-embedder audio mode.

Diode \ state	Red LED	Orange LED	Green LED	No light
<b>Card status</b>	PTC fuse has been triggered or FPGA programming has failed or laser has failed	Module has not been programmed	Module is OK	Module has no power
<b>SDI input status</b>	Video signal absent.	Electrical video signal present	Optical video signal Present	Module has not been programmed

Diode \ state	Red LED	Orange LED	Green LED	No light
<b>Audio status 1: Switch 2.7 off</b>	n/a	n/a	Always on (A/D converter is always on)	Module has not been programmed
<b>Audio status 2: Switch 2.7 off</b>	AES input 1 & 2 not present	Either AES input 1 or 2 present	AES input 1 & 2 both present	Module has not been programmed
<b>Audio status 1: Switch 2.7 on</b>	Group 1 & 2 not present	Either group 1 or 2 present	Group 1 & 2 both present	Module has not been programmed
<b>Audio status 2: Switch 2.7 on</b>	Group 3 & 4 not present	Either group 3 or 4 present	Group 3 & 4 both present	Module has not been programmed

### 5.3 GPI alarms

Only three alarms are present on the 8P8C Modular jack connector as four of the pins are used for the RS422 data port. The three alarms are:

- Power present (negative logic)
- Video signal lost
- Laser failure

An active alarm condition means that the transistor is conducting.

The power present alarm should always be active during normal operation.

## 6 Laser safety precautions

These are guidelines to limit hazards from laser exposure.

All the available EO and –T units in the Flashlink range include a laser.

Therefore this note on laser safety should be read thoroughly.

The lasers emit light at wavelengths from 1270nm up to 1610nm. This means that the human eye cannot see the beam, and the blink reflex cannot protect the eye. (The human eye can see light between 400 nm to 700 nm).

A laser beam can be harmful to the human eye (depending on laser power and exposure time). Therefore:

Be careful when connecting / disconnecting fiber pigtails (ends).

Never look directly into the pigtail of the laser/fiber.

Never use microscopes, magnifying glasses or eye loupes to look into a fiber end.

Use laser safety goggles blocking light at 1310 nm and at 1550 nm

Instruments exist to verify light output power: Power meters, IR-cards etc.

Flashlink features:

All the laser module cards in the Flashlink product range, are Class 1 laser products according to IEC 825-1 1993, and class I according to 21 CFR 1040.10 when used in normal operation.

More details can be found in the user manual for the FR-2RU-10-2 frame.

Maximum output power<sup>3</sup>: 5 mW

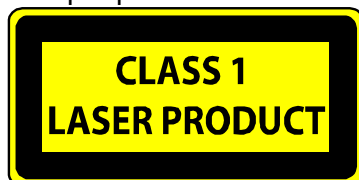

Operating wavelengths: > 1270 nm

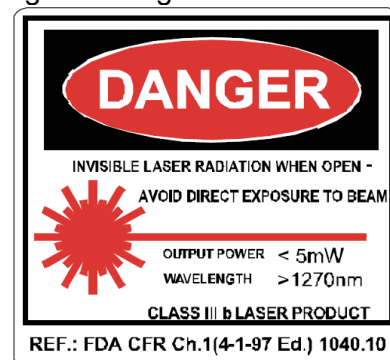

<sup>3</sup> Max power is for safety analysis only and does not represent device performance.

## **General environmental requirements for Nevion equipment**

1. The equipment will meet the guaranteed performance specification under the following environmental conditions:
  - Operating room temperature range: 0°C to 45°C
  - Operating relative humidity range: <90% (non-condensing)
  
2. The equipment will operate without damage under the following environmental conditions:
  - Temperature range: -10°C to 55°C
  - Relative humidity range: <95% (non-condensing)



## Product Warranty

The warranty terms and conditions for the product(s) covered by this manual follow the General Sales Conditions by Nevia AS. These conditions are available on the company web site of Nevia AS:

[www.nevia.com](http://www.nevia.com)

## Appendix A Materials declaration and recycling information

### A.1 Materials declaration

For product sold into China after 1st March 2007, we comply with the “Administrative Measure on the Control of Pollution by Electronic Information Products”. In the first stage of this legislation, content of six hazardous materials has to be declared. The table below shows the required information.

組成名稱 Part Name	Toxic or hazardous substances and elements					
	鉛 Lead (Pb)	汞 Mercury (Hg)	鎘 Cadmium (Cd)	六价铬 Hexavalent Chromium (Cr(VI))	多溴联苯 Polybrominated biphenyls (PBB)	多溴二苯醚 Polybrominated diphenyl ethers (PBDE)
ADC-SDI	○	○	○	○	○	○
AAV-SD-XMUX(-T)	○	○	○	○	○	○
<p>O: Indicates that this toxic or hazardous substance contained in all of the homogeneous materials for this part is below the limit requirement in SJ/T11363-2006.</p> <p>X: Indicates that this toxic or hazardous substance contained in at least one of the homogeneous materials used for this part is above the limit requirement in SJ/T11363-2006.</p>						

This is indicated by the product marking:



### A.2 Recycling information

Nevion provides assistance to customers and recyclers through our web site <http://www.nevion.com>. Please contact Nevion' Customer Support for assistance with recycling if this site does not show the information you require.

Where it is not possible to return the product to Nevion or its agents for recycling, the following general information may be of assistance:

- Before attempting disassembly, ensure the product is completely disconnected from power and signal connections.
- All major parts are marked or labeled to show their material content.
- Depending on the date of manufacture, this product may contain lead in solder.
- Some circuit boards may contain battery-backed memory device

# EC Declaration of Conformity

network

<b>MANUFACTURER</b>	Nevion AS P.B. 1020, N-3204 SANDEFJORD, Norway	
<b>AUTHORISED REPRESENTATIVE (Established within the EEA)</b>	Not applicable	
<b>MODEL NUMBER(S)</b>	ADC-SDI	
<b>DESCRIPTION</b>	NTSC/PAL to SDI encoder	
<b>DIRECTIVES this equipment complies with</b>	LVD 73/23/EEC EMC 2004/108/EEC	
<b>HARMONISED STANDARDS applied in order to verify compliance with Directive(s)</b>	EN 55103-1:1996 EN 55103-2:1996	
<b>TEST REPORTS ISSUED BY</b>	<b>Notified/Competent Body</b>	<b>Report no:</b>
	Nemko	E07379.00
<b>TECHNICAL CONSTRUCTION FILE NO</b>	Not applicable	
<b>YEAR WHICH THE CE-MARK WAS AFFIXED</b>	2008	
<b>TEST AUTHORIZED SIGNATORY</b>		
<b>MANUFACTURER</b>	<b>AUTHORISED REPRESENTATIVE (Established within EEA)</b>	<b>Date of Issue</b>
		2008-07-14
		<b>Place of Issue</b>
		Sandefjord, Norway
	Not applicable	
<b>Name</b>	Thomas Øhrbom	
<b>Position</b>	Quality Manager (authorized signature)	

  
**NETWORK ELECTRONICS AS**  
O.nr. 976 584 201 MVA

# EC Declaration of Conformity

network

<b>MANUFACTURER</b>	Nevion AS P.B. 1020, N-3204 SANDEFJORD, Norway	
<b>AUTHORISED REPRESENTATIVE (Established within the EEA)</b>	Not applicable	
<b>MODEL NUMBER(S)</b>	AAV-HD-XMUX(-T/R)/ AAV-SD-XMUX(-T/R)	
<b>DESCRIPTION</b>	HD/SD analog/digital audio embedder	
<b>DIRECTIVES this equipment complies with</b>	LVD 73/23/EEC EMC 2004/108/EEC	
<b>HARMONISED STANDARDS applied in order to verify compliance with Directive(s)</b>	EN 55103-1:1996 EN 55103-2:1996	
<b>TEST REPORTS ISSUED BY</b>	<b>Notified/Competent Body</b>	<b>Report no:</b>
	Nemko	67639001
<b>TECHNICAL CONSTRUCTION FILE NO</b>	Not applicable	
<b>YEAR WHICH THE CE-MARK WAS AFFIXED</b>	2007	
<b>TEST AUTHORIZED SIGNATORY MANUFACTURER</b>	<b>AUTHORISED REPRESENTATIVE (Established within EEA)</b>	<b>Date of Issue</b>
		2007-04-19
		<b>Place of Issue</b>
	Not applicable	Sandefjord, Norway
<b>Name</b>	Thomas Øhrbom	
<b>Position</b>	Quality Manager (authorized signature)	

  
**NETWORK ELECTRONICS AS**  
O.nr. 976 584 201 MVA